

VTC1019

Full-Size Socket 478 Pentium 4
Intel 845G CPU Card

USER'S MANUAL

Version 1.0

Acknowledgments

Award is a registered trademark of Award Software International, Inc.

PS/2 is a trademark of International Business Machines Corporation.

Intel and Pentium 4 are registered trademarks of Intel Corporation.

Microsoft Windows is a registered trademark of Microsoft Corporation.

Winbond is a registered trademark of Winbond Electronics Corporation.

All other product names or trademarks are properties of their respective owners.

Table of Contents

Introduction	1
Product Description	1
Checklist	2
Specifications	3
Board Dimensions.....	4
Installations.....	5
Installing the CPU.....	6
ATX Power Installation.....	7
MicroPCI Daughter Card Installation	7
Installing the Memory.....	8
Setting the Jumpers.....	9
Connectors on VTC1019	14
Watchdog Timer.....	26
BIOS Setup.....	錯誤! 尚未定義書籤。
Drivers Installation	錯誤! 尚未定義書籤。
Appendix	錯誤! 尚未定義書籤。
A. I/O Port Address Map.....	錯誤! 尚未定義書籤。
B. Interrupt Request Lines (IRQ)	錯誤! 尚未定義書籤。

This page is intentionally left blank.

Introduction

Product Description

The VTC1019 Pentium 4 Full Size PICMG CPU Card incorporates the Intel® advanced 845G Chipset Memory Controller hub and supports 478-pin Intel Pentium 4 processors of 1.3GHz and up to 2.6GHz+ with FSB 533MHz/400MHz. VTC1019 supports the Pentium 4 processor with 256-KB L2 cache and the Pentium 4 processor with 512-KB L2 cache on 0.13 micron process.

The I/O functions are on VTC1019 integrated onto the ICH4. It supports either the integrated graphics device (IGD) on the GMCH or an external graphics device on AGP. The IGD has 3D, 2D, and video capabilities. The system memory size can be up to 2 GB, using the two DDR sockets on board. Six USB ports are supported with the USB 1.1/2.0 standard.

VTC1019 optionally supports the ATI Mobility M7 graphics controller with 16MB or 32MB embedded memory. Interface supported are LVDS, TMDS and dual CRT. The VGA functionality offers unprecedented video quality and *integrated MPEG-2 decode capability*. VTC1019 also optionally comes with an Intel 82540 Gigabit LAN controller for faster networking access.

VTC1019 supports a MicroPCI socket for MicroPCI daughter cards with VGA, VGA/LAN, Ethernet (LAN), SCSI, and IEEE 1394 functions.

This CPU card represents the perfect choice for those who want superior performance for rugged and demanding applications in industrial automation, image processing, multimedia and telecommunications.

Checklist

Your VTC1019 package should include the items listed below.

- The VTC1019 Industrial CPU Card
- This User' s Manual
- 1 IDE Ribbon Cable
- 1 Floppy Ribbon Connector
- 2 Serial Port Ribbon Cable and 1 Parallel Port Attached to a Mounting Bracket
- 1 Y-Cable supporting a PS/2 Keyboard and a PS/2 Mouse
- 1 CD containing the following:
 - Chipset Drivers
 - Flash Memory Utility
- Optional audio cable with bracket (Audio8K)
- Optional USB cable with bracket (USB2K)
- Optional Secondary CRT VGA cable with bracket (VGA4K)
- Optional TMDS/CRT cable with bracket (ID120P)

Specifications

CPU Socket	Socket 478
CPU	Intel Pentium 4, 1.30GHz ~ 2.6GHz+
CPU Front Side Bus	533MHz / 400MHz
Chipset	Intel 845G Chipset
L2 Cache	128K/256K/512K, CPU integrated
BIOS	Award BIOS, ACPI supported
System Memory	Two DDR sockets, up to 2GB DDR SDRAM
Integrated VGA	Intel 845G integrated VGA Supports CRT interface
Optional VGA	ATI Mobility M7 graphics controller 16MB/32MB embedded memory Frame buffer (DDR, AGP4) LVDS/TMDS/dual CRT interface
LAN	ICH4 integrated Ethernet controller 10Base-T / 100Base-TX Protocol Optional Gigabit Ethernet solution
Audio	ICH4 integrated audio Optional AC97 codec and audio cable
LPC I/O	W83627HF chipset supports IrDA x 1, Parallel x 1, COM1 (RS232), COM2 (RS232/422/485), FDC up to 2.88MB (3Mode support) Hardware Monitor (3 thermal inputs, 6 voltage monitor inputs, VID0-4, 3 fan headers)
IDE Interface	Built in ICH4; Two enhanced IDE supports 4 IDE devices including UDMA33/66/100, PIO mode 4 and bus master
FDD Interface	Supports up to two floppy disk drives: 3.5" and/or 5.25" drives; 3 Mode support
Parallel Port	One parallel port supports SPP/EPP/ECP
Serial Ports	One RS-232/422/485 and one RS-232 port
Watchdog Timer	Generates system reset; 256 levels
SSD Interface	Supports 2MB~144MB M-Systems DiskOnChip flash disk
Hardware Monitoring	Built in W83627HF; monitors system/CPU temperature and voltage status
USB	Supports 6 USB ports, USB 1.1/2.0 compliant
IrDA	Pin header
Keyboard and Mouse	PS/2 type connectors
Extra Features	ISA High Drive, PCI to ISA Bridge (ITE 8888) One MicroPCI socket, ATX 12V power connector
Power Consumption	Pentium 4 1.8GHz with 512MB DDR SDRAM +5V: 5.7A +12V: 8.5A Pentium 4 2.2GHz with 512MB DDR SDRAM +5V: 6.4A +12V: 6.3A
Form Factor	Full Size CPU Card
Dimensions	338mm x 122mm (13.3" x 4.8")

Board Dimensions

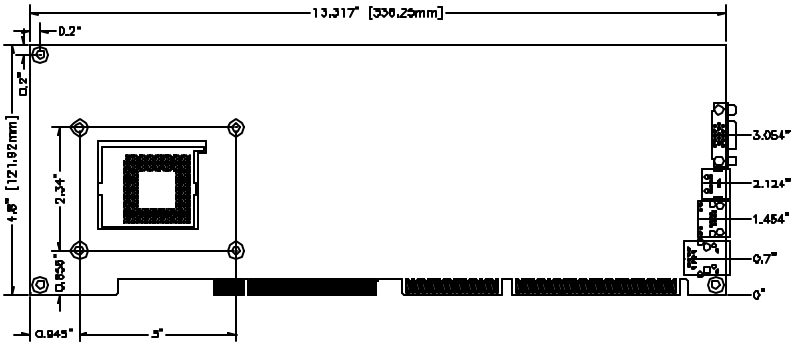

Installations

This section provides information on how to use the jumpers and connectors on the VTC1019 in order to set up a workable system. The topics covered are:

Installing the CPU	6
ATX Power Installation	7
MicroPCI Daughter Card Installation.....	7
Installing the Memory	8
Setting the Jumpers.....	9
Connectors on VTC1019	14
Watchdog Timer.....	26

Installing the CPU

The VTC1019 CPU Card supports a Socket 478 processor socket for Intel Pentium 4 processors.

The Socket 478 processor socket comes with a lever to secure the processor. Raise this lever to about a 90° angle to allow the insertion of the processor. Place the processor into the socket by making sure the notch on the corner of the CPU corresponds with the notch on the inside of the socket. Once the processor has slide into the socket, return the lever to the lock position. Refer to the figures below.

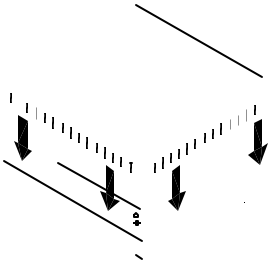

After you have installed the processor into the socket, check if the jumpers for the CPU type and speed are correct.

NOTE: *Ensure that the CPU heat sink and the CPU top surface are in total contact to avoid CPU overheating problem that would cause your system to hang or be unstable.*

ATX Power Installation

The system power is provided to the VTC1019 CPU card with the J1 and J8 ATX power connectors. Please note that the J8 external ATX power connector should be connected to the backplane for VTC81019 to function. J8 is a 3-pin power connector. J1 is a 4-pin 12V power connector. J1 is to be connected to the ATX power supply.

MicroPCI Daughter Card Installation

To insert the MicroPCI daughter cards, position it at 30° to the PCB and gently push it into the MicroPCI connector (See Figure 1 below). The card will not fit when inserted at an angle of 45° or 15°. Once inserted, slowly press the card towards the PCB until it locks on both sides to the clips of the connector. Screw the card to the PCB to secure the installation. To remove the MicroPCI card, pull the ‘clips’ sideways as shown in Figure 2 below.

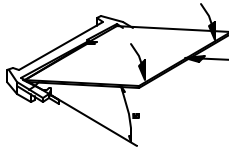

Figure 1.

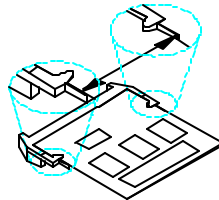

Figure 2.

Installing the Memory

The VTC1019 CPU Card supports two DDR memory sockets for a maximum total memory of 2GB in DDR memory type. The memory module capacities supported are 64MB, 128MB, 256MB, 512MB and 1GB. The following table lists the supported SDR DIMM configurations. Intel 845G supports configurations defined in the JEDEC DDR DIMM specification only (A,B,C). Non-JEDEC standard DIMMs such as double-sided x16 DDR SDRAM DIMMs are not supported.

Supported DDRM DIMM Configurations.

Density	64 Mbit		128Mbit		256Mbit		512Mbit	
Device Width	X8	X16	X8	X16	X8	X16	X8	X16
Single/Double	SS/DS	SS/DS	SS/DS	SS/DS	SS/DS	SS/DS	SS/DS	SS/DS
184-pin DDR	64/128MB	32MB/NA	128/256MB	64MB/NA	256/512MB	128MB/NA	512/1024M	256MB/NA

Installing and Removing Memory Modules

To install the DDR modules, locate the memory slot on the CPU card and perform the following steps:

1. Hold the DDR module so that the key of the DDR module align with those on the memory slot.
2. Gently push the DDR module in an upright position until the clips of the slot close to hold the DDR module in place when the DDR module touches the bottom of the slot.
3. To remove the DDR module, press the clips with both hands.

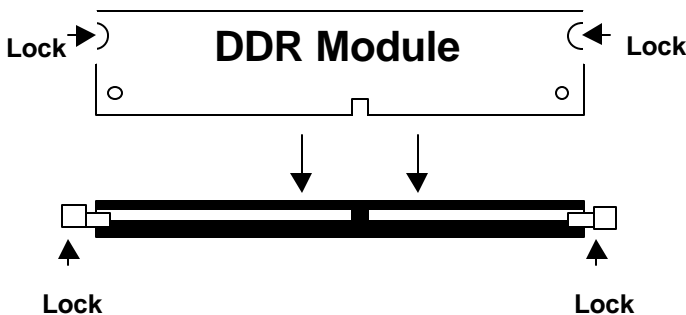

Setting the Jumpers

Jumpers are used on VTC1019 to select various settings and features according to your needs and applications. Contact your supplier if you have doubts about the best configuration for your needs. The following lists the connectors on VTC1019 and their respective functions.

Jumper Locations on VTC1019.....	10
Configuring the CPU Frequency.....	11
JP16: CPU Front Side Bus Select.....	11
JP2, JP3, JP4: RS232/422/485 (COM2) Selection	11
JP5: DiskOnChip Address Select	11
JP6: Clear CMOS Contents	12
JP8, JP9, JP10, JP11, JP12: CRT VGA Signal Select	12
JP13: Gigabit LAN Enable/Disable	12
SW1: LVDS Resolution Select.....	13

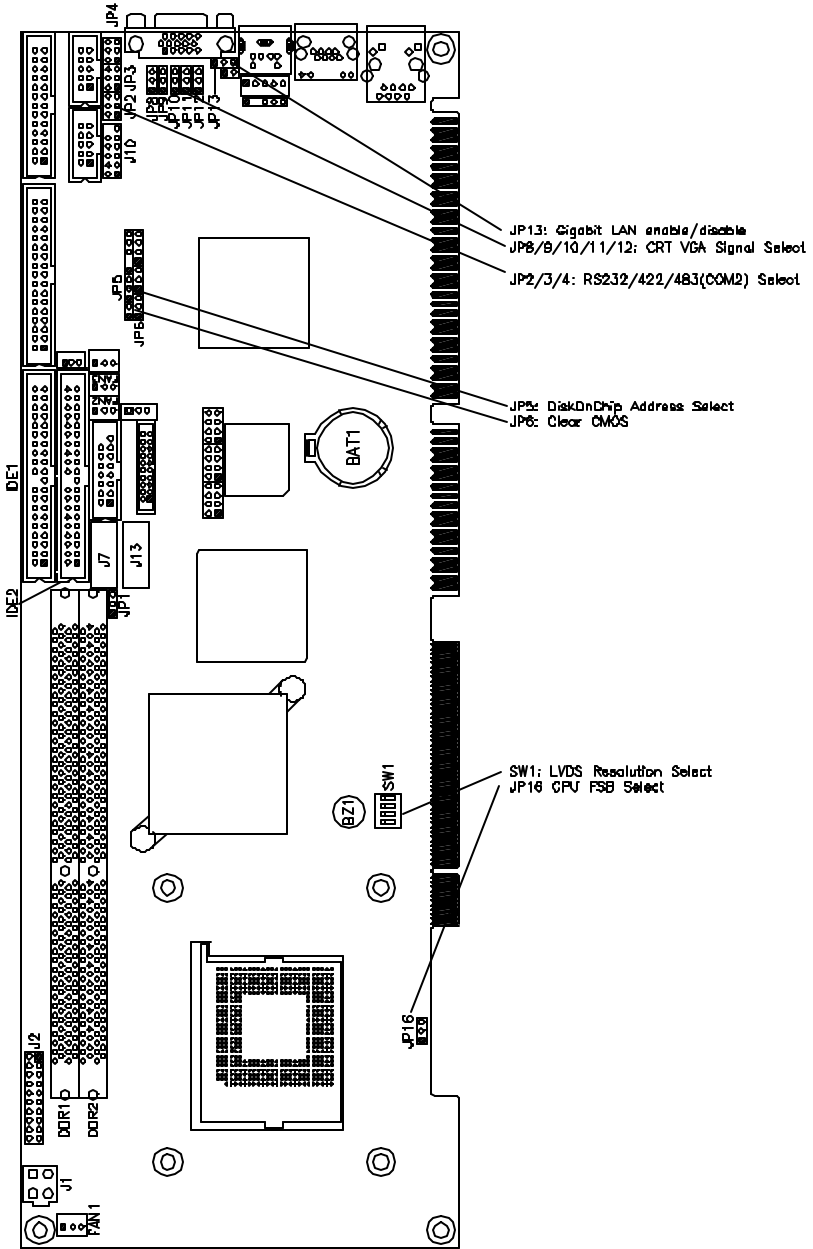

Jumper Locations on VTC1019



Configuring the CPU Frequency

The VTC1019 CPU card does not provide DIP switches to configure the processor speed (CPU frequency). However, JP16 can be used to select the Front Side Bus of the processor.

JP16: CPU Front Side Bus Select

JP16	Front Side Bus
 1 2 3	Auto (Default)
 1 2 3	100Mhz
 1 2 3	133Mhz

JP2, JP3, JP4: RS232/422/485 (COM2) Selection

COM1 is fixed for RS-232 use only.

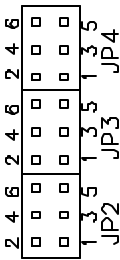

COM2 is selectable for RS232, RS-422 and RS-485.

The following table describes the jumper settings for COM2 selection.





COM2 Function	RS-232	RS-422	RS-485
Jumper Setting (pin closed)	JP2: 1-2	JP2: 3-4	JP2: 5-6
	JP3: 3-5 & 4-6	JP3: 1-3 & 2-4	JP3: 1-3 & 2-4
	JP4: 3-5 & 4-6	JP4: 1-3 & 2-4	JP4: 1-3 & 2-4

JP5: DiskOnChip Address Select

JP5	Address
 1 2 3	D0000-D7FFF
 1 2 3	D8000-DFFFF (default)



JP6: Clear CMOS Contents

Use JP6, a 3-pin header, to clear the CMOS contents. *Note that the ATX-power connector should be disconnected from the CPU card before clearing CMOS.*



JP6	Setting	Function
	Pin 1-2 Short/Closed	Normal
	Pin 2-3 Short/Closed	Clear CMOS

JP8, JP9, JP10, JP11, JP12: CRT VGA Signal Select

Use JP8, JP9, JP10, JP11, and JP12 to select the CRT VGA signal, either from the on board VGA or from an optional MicroPCI VGA.

JP8/9/10/11/12	Function
	On Board VGA
	MicroPCI VGA

JP13: Gigabit LAN Enable/Disable

JP13	Function
	Enable Gigabit LAN
	Disable Gigabit LAN

* Note: Use this jumper only when your CPU card has the Gigabit LAN function.

SW1: LVDS Resolution Select

SW1-1	SW1-2	SW1-3	Resolution
OFF	ON	ON	800x600 18 bit
ON	OFF	ON	1024x768 18bit
OFF	OFF	ON	1024x768 24 bit

Connectors on VTC1019

The connectors on VTC1019 allows you to connect external devices such as keyboard, floppy disk drives, hard disk drives, printers, etc. The following table lists the connectors on VTC1019 and their respective functions.

Connector Locations on VTC1019.....	15
IDE1, IDE2: EIDE Connectors.....	16
FDD1: Floppy Drive Connector.....	17
J1: ATX 12V/+12V Power Connector.....	17
FAN1: CPU Fan Power Connector.....	17
FAN2: System Fan Power Connector.....	18
FAN3: Auxiliary Fan Power Connector.....	18
J2: System Function Connector.....	18
J3: Parallel Port Connector.....	20
J5, J6: COM1 and COM2 Serial Ports Connector.....	21
J7, J13: LVDS Connectors (2nd channel, 1st channel).....	21
J8: External ATX Power Connector.....	22
J9: CRT2 / TV-Out Connector.....	22
J10: External Audio Connector.....	22
J12: IrDA Connector.....	23
J15: CD-In Audio Connector.....	23
J16: TMDS Panel Connector (on ID120).....	23
J17: VGA CRT Connector.....	24
J18, J19, J20: USB Connectors.....	24
J21, J22: External PS/2 Keyboard and Mouse Connector.....	25
J23: PS/2 Keyboard and Mouse Connector.....	25
J25: Gigabit LAN RJ45 Connector.....	25
J26: Primary RJ45 Connector.....	25

Connector Locations on VTC1019

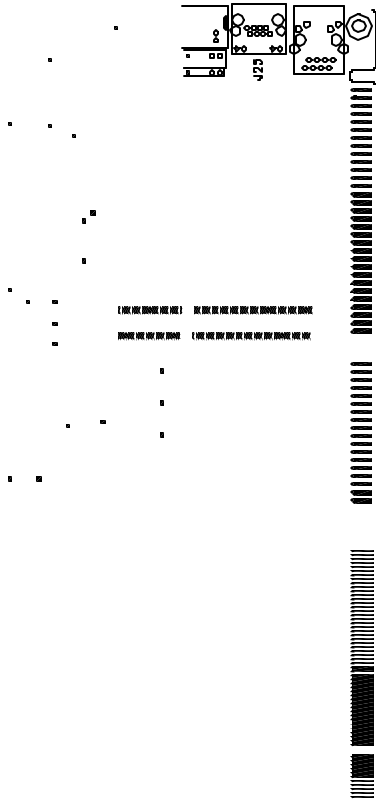

- IDE1, IDE2: EIDE Connectors
- FDD1: Floppy Drive Connector
- J1: ATX 12V/+12V Power Connector
- FAN1: CPU Fan Power Connector
- FAN2: System Fan Power Connector
- FAN3: Auxiliary Fan Power Connector
- J2: System Function Connector
- J3: Parallel Port Connector
- J5, J6: COM1 and COM2 Serial Ports
- J7, J13: LVDS Connectors
- J8: External ATX Power Connector
- J9: CRT2 / TV-Out Connector
- J10: External Audio Connector
- J12: IrDA Connector
- J15: CD-In Audio Connector
- J16: TMDS Panel Connector (on ID120)
- J17: VGA CRT Connector
- J18, J19, J20: USB Connectors
- J21, J22: External PS/2 KB and Mouse
- J23: PS/2 Keyboard and Mouse
- J25: Gigabit LAN RJ45 Connector (option)
- J26: Primary RJ45 Connector

IDE1, IDE2: EIDE Connectors

IDE1: Primary IDE Connector

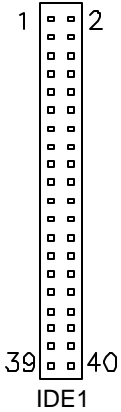

Signal Name	Pin #	Pin #	Signal Name
Reset IDE	1	2	Ground
Host data 7	3	4	Host data 8
Host data 6	5	6	Host data 9
Host data 5	7	8	Host data 10
Host data 4	9	10	Host data 11
Host data 3	11	12	Host data 12
Host data 2	13	14	Host data 13
Host data 1	15	16	Host data 14
Host data 0	17	18	Host data 15
Ground	19	20	Protect pin
DRQ0	21	22	Ground
Host IOW	23	24	Ground
Host IOR	25	26	Ground
IOCHRDY	27	28	Host ALE
DACK0	29	30	Ground
IRQ14	31	32	No connect
Address 1	33	34	No connect
Address 0	35	36	Address 2
Chip select 0	37	38	Chip select 1
Activity	39	40	Ground

IDE2: Secondary IDE Connector

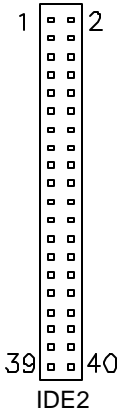

Signal Name	Pin #	Pin #	Signal Name
Reset IDE	1	2	Ground
Host data 7	3	4	Host data 8
Host data 6	5	6	Host data 9
Host data 5	7	8	Host data 10
Host data 4	9	10	Host data 11
Host data 3	11	12	Host data 12
Host data 2	13	14	Host data 13
Host data 1	15	16	Host data 14
Host data 0	17	18	Host data 15
Ground	19	20	Protect pin
DRQ1	21	22	Ground
Host IOW	23	24	Ground
Host IOR	25	26	Ground
IOCHRDY	27	28	Host ALE
DACK1	29	30	Ground
IRQ15	31	32	No connect
Address 1	33	34	No connect
Address 0	35	36	Address 2
Chip select 0	37	38	Chip select 1
Activity	39	40	Ground

FDD1: Floppy Drive Connector

FDD1 is a 34-pin header and will support up to 2.88MB floppy drives.

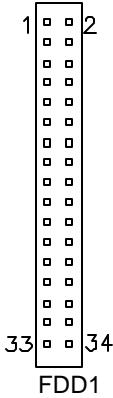

Signal Name	Pin #	Pin #	Signal Name
Ground	1	2	RM/LC
Ground	3	4	No connect
Ground	5	6	No connect
Ground	7	8	Index
Ground	9	10	Motor enable 0
Ground	11	12	Drive select 1
Ground	13	14	Drive select 0
Ground	15	16	Motor enable 1
Ground	17	18	Direction
Ground	19	20	Step
Ground	21	22	Write data
Ground	23	24	Write gate
Ground	25	26	Track 00
Ground	27	28	Write protect
Ground	29	30	Read data
Ground	31	32	Side 1 select
Ground	33	34	Diskette change

J1: ATX 12V/+12V Power Connector

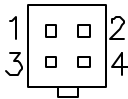

Pin #	Signal Name
1	Ground
2	Ground
3	+12V
4	+12V

FAN1: CPU Fan Power Connector

FAN1 is a 3-pin header for the CPU fan. The fan must be a 12V fan.

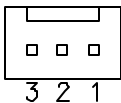

Pin #	Signal Name
1	Ground
2	+12V
3	Rotation detection

FAN2: System Fan Power Connector

FAN2 is a 3-pin header for the system fan. The fan must be a 12V fan.

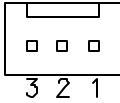

Pin #	Signal Name
1	Ground
2	+12V
3	Rotation detection

FAN3: Auxiliary Fan Power Connector

FAN3 is a 3-pin header for a 12V fan.

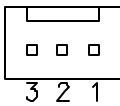

Pin #	Signal Name
1	Ground
2	+12V
3	Rotation detection

J2: System Function Connector

J2 provides connectors for system indicators that provide light indication of the computer activities and switches to change the computer status. J2 is a 20-pin header that provides interfaces for the following functions.

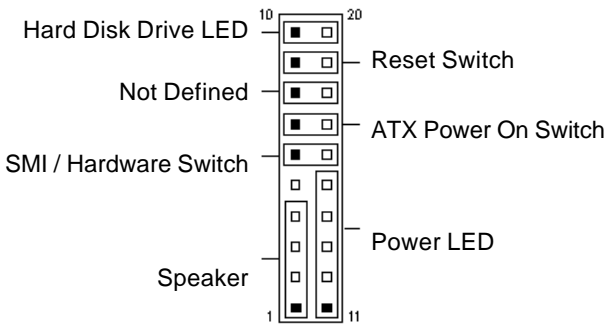

Speaker: Pins 1 - 4

This connector provides an interface to a speaker for audio tone generation. An 8-ohm speaker is recommended.

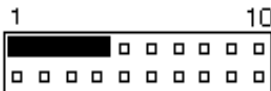

Pin #	Signal Name
1	Speaker out
2	No connect
3	Ground
4	+5V

Power LED: Pins 11 - 15

The power LED indicates the status of the main power switch.



Pin #	Signal Name
11	Power LED
12	No connect
13	Ground
14	No connect
15	Ground

SMI/Hardware Switch: Pins 6 and 16

This connector supports the "Green Switch" on the control panel, which, when pressed, will force the system into the power-saving mode immediately.

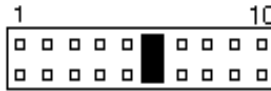

Pin #	Signal Name
6	SMI
16	Ground

ATX Power ON Switch: Pins 7 and 17

This 2-pin connector is an "ATX Power Supply On/Off Switch" on the system that connects to the power switch on the case. When pressed, the power switch will force the system to power on. When pressed again, it will force the system to power off.

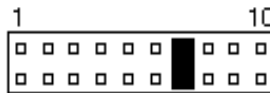

Reset Switch: Pins 9 and 19

The reset switch allows the user to reset the system without turning the main power switch off and then on again. Orientation is not required when making a connection to this header.

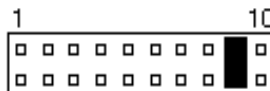

Hard Disk Drive LED Connector: Pins 10 and 20

This connector connects to the hard drive activity LED on control panel. This LED will flash when the HDD is being accessed.



Pin #	Signal Name
10	HDD Active
20	5V

J3: Parallel Port Connector

The following table describes the pin out assignments of this connector.

A diagram of a 26-pin parallel port connector. The pins are arranged in two columns of 13 pins each. The left column is labeled '1' at the top and '13' at the bottom. The right column is labeled '14' at the top and '26' at the bottom. The connector is labeled 'J3' at the bottom left.

Signal Name	Pin #	Pin #	Signal Name
Line printer strobe	1	14	AutoFeed
PD0, parallel data 0	2	15	Error
PD1, parallel data 1	3	16	Initialize
PD2, parallel data 2	4	17	Select
PD3, parallel data 3	5	18	Ground
PD4, parallel data 4	6	19	Ground
PD5, parallel data 5	7	20	Ground
PD6, parallel data 6	8	21	Ground
PD7, parallel data 7	9	22	Ground
ACK, acknowledge	10	23	Ground
Busy	11	24	Ground
Paper empty	12	25	Ground
Select	13	N/A	N/A

J5, J6: COM1 and COM2 Serial Ports Connector

J5 and J6 both 10-pin headers, are the onboard serial port connectors.

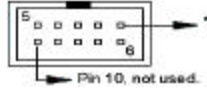

J5
Fixed as
RS-232

J6
Configurable
as RS-232/ RS-
422/485 with
jumpers
JP2/JP3/JP4

Pin #	Signal Name		
	RS-232	RS-422	RS-485
1	DCD	TX-	DATA-
2	RX	TX+	DATA+
3	TX	RX+	NC
4	DTR	RX-	NC
5	GND	GND	GND
6	DSR	RTS-	NC
7	RTS	RTS+	NC
8	CTS	CTS+	NC
9	RI	CTS-	NC
10	NC	NC	NC

J7, J13: LVDS Connectors (2nd channel, 1st channel)

The LVDS connectors are composed of the first channel (J13) and second channel (J7) to support 24-bit or 48-bit.

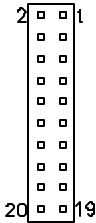

Signal Name	Pin #	Pin #	Signal Name
TX0-	2	1	TX0+
Ground	4	3	Ground
TX1-	6	5	TX1+
5V/3.3V	8	7	Ground
TX3-	10	9	TX3+
TX2-	12	11	TX2+
Ground	14	13	Ground
TXC-	16	15	TXC+
5V/3.3V	18	17	ENABKL
+12V	20	19	+12V

J8: External ATX Power Connector

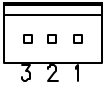

Pin #	Signal Name
1	Ground
2	PS-ON (soft on/off)
3	5VSB (Standby +5V)

J9: CRT2 / TV-Out Connector

This connector allows you to connect to a second CRT monitor or use with a TV output device.

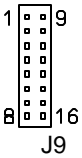

Signal Name	Pin #	Pin #	Signal Name
Red / C	1	9	+5V
Green / Y	2	10	Ground
Blue / COMP	3	11	N. C.
N.C.	4	12	CRT2 DDCDAT
Ground	5	13	HSYNC
Ground	6	14	VSYNC
Ground	7	15	CRT2 DDCCLK
Ground	8	16	N.C.

J10: External Audio Connector

J10 is a 12-pin header that is used to connect to the ID120 daughter card that integrates jacks for Line In, Line Out and Speaker.

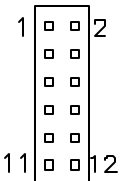

Signal Name	Pin #	Pin #	Signal Name
LINEOUT_R	1	2	LINEOUT_L
Ground	3	4	Ground
LINEIN_R	5	6	LINEIN L
Ground	7	8	Ground
Mic-In	9	10	VREFOUT
Ground	11	12	Protect pin

J12: IrDA Connector

J12 is used for an optional IrDA connector for wireless communication.

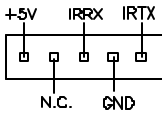

Pin #	Signal Name
1	+5V
2	No connect
3	Ir RX
4	Ground
5	Ir TX

J15: CD-In Audio Connector



Pin #	Signal Name
1	CD Audio R
2	Ground
3	Ground
4	CD Audio L

J16: TMDS Panel Connector (on ID120)

TMDS stands Transition Minimized Differential Signaling. J16 TMDS panel connector is to be connected to the optional ID120 daughter card.

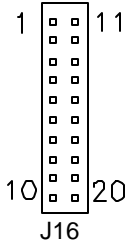

Signal Name	Pin #	Pin #	Signal Name
TX1P	1	11	TX2P
TXIN	2	12	TX2N
GND	3	13	GND
GND	4	14	GND
TXCP	5	15	TX0P
TXCN	6	16	TX0N
GND	7	17	NC
+5v	8	18	NC
HTPG	9	19	DDCDATA
NC	10	20	DDCCLK

J17: VGA CRT Connector

The pin assignments of the J17 VGA CRT connector are as follows:

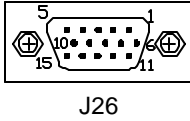

Signal Name	Pin	Pin	Signal Name
Red	1	2	Green
Blue	3	4	N.C.
GND	5	6	GND
GND	7	8	GND
N.C.	9	10	GND
N.C.	11	12	N.C.
HSYNC	13	14	VSYNC
NC	15		

J18, J19, J20: USB Connectors

The following table shows the pin outs of the USB pin headers connectors. Overall, the two pin headers support four USB ports.

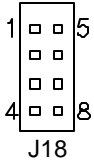

Signal Name	Pin	Pin	Signal Name
Vcc	1	5	Ground
USB0-	2	6	USB1+
USB0+	3	7	USB1-
Ground	4	8	Vcc

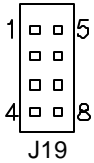

Signal Name	Pin	Pin	Signal Name
Vcc	1	5	Ground
USB2-	2	6	USB3+
USB2+	3	7	USB3-
Ground	4	8	Vcc

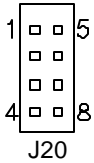

Signal Name	Pin	Pin	Signal Name
Vcc	1	5	Ground
USB4-	2	6	USB5+
USB4+	3	7	USB5-
Ground	4	8	Vcc

J21, J22: External PS/2 Keyboard and Mouse Connector

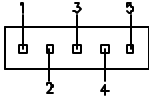

Pin #	J21	J22
1	Mouse data	KB clock
2	N.C.	KB data
3	Ground	N.C.
4	Vcc	Ground
5	Mouse clock	Vcc

J23: PS/2 Keyboard and Mouse Connector

J23 uses a Y-cable with dual D-connectors for a PS/2 keyboard and a PS/2 mouse.

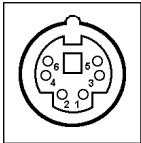

J23

Pin #	Signal Name
1	Mouse data
2	Keyboard data
3	Ground
4	Vcc
5	Mouse Clock
6	Keyboard Clock

J25: Gigabit LAN RJ45 Connector

J25 is the Gigabit LAN RJ45 connector.

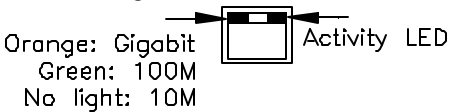

* Note: This connector is only present when your CPU card has the Gigabit LAN function.

J26: Primary RJ45 Connector

J26 is the primary RJ-45 connector based on the chipset integrated LAN. The figure below shows the pin out assignments of the connector and its corresponding input jack.

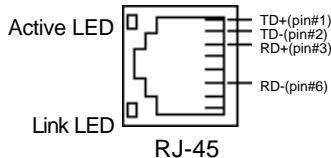

Watchdog Timer Configuration

The WDT is used to generate a variety of output signals after a user programmable count. The WDT is suitable for use in the prevention of system lock-up, such as when software becomes trapped in a deadlock. Under these sort of circumstances, the timer will count to zero and the selected outputs will be driven. Under normal circumstance, the user will restart the WDT at regular intervals before the timer counts to zero.

SAMPLE CODE:

This code and information is provided "as is" without warranty of any kind, either expressed or implied, including but not limited to the implied warranties of merchantability and/or fitness for a particular purpose.

```

;[]=====
;Name  :Enable_And_Set_Watchdog
;IN    : AL - 1sec ~ 255sec
;OUT   : None
;[]=====
Enable_And_Set_Watchdog Proc Near
    push ax          ;save time interval
    call Unlock_Chip

    mov cl, 2Bh
    call Read_Reg
    and al, NOT 10h
    call Write_Reg   ;set GP24 as WDTO

    mov cl, 07h
    mov al, 08h
    call Write_Reg   ;switch to LD8
    
```

```

        mov     cl, 0F5h
        call  Read_Reg
        and     al, NOT 08h
        call  Write_Reg      ;set count mode as second

        pop ax
        mov     cl, 0F6h
        call  Write_Reg      ;set watchdog timer

        mov     al, 01h
        mov     cl, 30h
        call  Write_Reg      ;watchdog enabled

        call  Lock_Chip
        ret
Enable_And_Set_Watchdog  Endp
;[]=====
;Name  : Disable_Watchdog
;IN    : None
;OUT   : None
;[]=====
Disable_Watchdog  Proc    Near
        call  Unlock_Chip

        mov     cl, 07h
        mov     al, 08h
        call  Write_Reg      ;switch to LD8

        xor    al, al
        mov     cl, 0F6h
        call  Write_Reg      ;clear watchdog timer

        xor    al, al
        mov     cl, 30h
        call  Write_Reg      ;watchdog disabled

        call  Lock_Chip
        ret
Disable_Watchdog  Endp
;[]=====

```

INSTALLATIONS

```
; Name : Unlock_Chip
; IN : None
; OUT : None
```

```
;[]=====
```

```
Unlock_Chip Proc Near
    mov dx, 2Eh
    mov al, 87h
    out dx, al
    out dx, al
    ret
```

```
Unlock_Chip Endp
```

```
;[]=====
```

```
; Name : Lock_Chip
; IN : None
; OUT : None
```

```
;[]=====
```

```
Unlock_Chip Proc Near
    mov dx, 2Eh
    mov al, 0AAh
    out dx, al
    ret
```

```
Unlock_Chip Endp
```

```
;[]=====
```

```
; Name : Write_Reg
; IN : CL - register index
; AL - Value to write
; OUT : None
```

```
;[]=====
```

```
Write_Reg Proc Near
    push ax
    mov dx, 2Eh
    mov al, cl
    out dx, al
    pop ax
    inc dx
    out dx, al
    ret
```

```
Write_Reg Endp
```

```
;[]=====
```

```
; Name : Read_Reg  
; IN : CL - register index  
; OUT : AL - Value to read
```

```
;[]=====
```

Read_Reg	Proc	Near
	mov	al, cl
	mov	dx, 2Eh
	out	dx, al
	inc	dx
	in	al, dx
	ret	

```
Read_Reg Endp  
;[]=====
```

This page was intentionally left blank.

