

AMB-2000/2020 Series
Modular System Industrial Panel PCs
Version 1.1 Beta

Industrial Panel PCs
Industrial Panel PCs for Industrial Automation
User's Manual

Contents

Chapter1 General Information.....	1
1.1 Introduction.....	2
1.2 Specifications.....	3
General	3
Environmental	3
Rear View picture.....	3
Features	4
Specifications	5
Power Supply Selection Table.....	6
1.3 Touchscreen (Optional)	7
1.4 Order Information.....	8
1.5 LCD Specifications	9
1.6 Dimensions	10
1.7 Panel Mounting.....	12
1.8 Packing List.....	14
Chapter2 The SBC Board MBC-4860	15
2.1 Description	16
2.2 Features	17
2.3 Specifications.....	18
2.4 Intelligence	20
2.5 Board Dimensions	21
Chapter3 MBC-4860 Installations	22
3.1 CPU Installation.....	23
3.2 Memory Installation.....	24
3.3 Jumpers on the MBC-4860	25
Jumper Locations on the MBC-4860	26
SW3: CPU Voltage Selector	27
U13: CPU Frequency Selector	27
JP10: RS232/422/485 (COM2) Selection.....	28
JP6: LCD Power Setting.....	29
JP12: Clear CMOS.....	29
JP16: DiskOnChip BIOS Expansion Address Select	30
JP14: Reset Button Connector	30
3.4 Connectors on the MBC-4860.....	31
Connector Locations on the MBC-4860	32
JP1, JP2: Fan Power Connectors.....	33

J2: Parallel Port Connector.....	33
J4, J17: Floppy Drive Connectors	34
J6, J8, J9: COM1/2/3 Serial Ports	35
J7: VGA Port Connector	35
JP7: Power Switch Connector	36
JP9: Power Connector	36
J10: PS/2 Keyboard Connector	36
J11: RJ45 Connector	36
J12: PS/2 Mouse Connector	37
JP13: IrDA Connector	37
J13: USB Connector.....	37
JP15: HDD LED.....	37
J14, J15: PC-104 Connector	39
J18, J16: EIDE Connectors.....	40
JP18, JP19: DC-Out Connectors.....	41
Chapter4 Hardware and Installation	42
Exploded Diagram	43
Cooling Fan Replacement.....	44
Install a 3.5" HDD	45
Install a Slim CD-Rom and 2.5" HDD	46
Install a Slim FDD and 2.5" HDD	47
Chapter5 BIOS Configuration.....	48
BIOS Introduction	49
BIOS Setup.....	49
Standard CMOS Setup.....	51
BIOS Features Setup	54
Chipset Features Setup.....	57
Power Management Setup	58
PNP/PCI Configuration.....	60
Load BIOS Defaults	61
Load Setup Defaults	62
Integrated Peripherals	63
Supervisor / User Password.....	66
IDE HDD Auto Detection.....	67
Save & Exit Setup.....	68
Exit Without Saving.....	68
Chapter6 VGA/Audio Driver Installation.....	69
Installing VGA Drivers for Windows 9x.....	70

Installing VGA Drivers for Windows NT 4.0.....	72
Installing IDE Drivers for Windows NT 4.0.....	72
Chapter7 LAN Driver Installation.....	73
Introduction.....	74
Features.....	74
Installing LAN Driver for Window 98/2000.....	75
Installing LAN Driver for Windows 95.....	76
Installing LAN Driver for Windows NT.....	77
Installing LAN Driver for DOS.....	78
Installing Driver for Windows for Workgroups.....	79
Appendix.....	80
A. I/O Port Address Map.....	81
B. Interrupt Request Lines (IRQ).....	82

1

Chapter 1 General Information

<u>1.1</u>	<u>Introduction</u>	2
<u>1.2</u>	<u>Specifications</u>	3
<u>1.3</u>	<u>Touchscreen (Optional)</u>	7
<u>1.4</u>	<u>Order Information</u>	8
<u>1.5</u>	<u>LCD Specifications</u>	9
<u>1.6</u>	<u>Dimensions</u>	10
<u>1.7</u>	<u>Panel Mounting</u>	12
<u>1.8</u>	<u>Packing List</u>	14

1.1 Introduction

The AMB-2000/2020 series modular system panel PCs, is the PC-base industrial computer that specially designed to keep normal operation under harsh environment, which meet the entire requirement as an industrial man machine interface (MMI).

They provide a complete hard ware application and construct a high quality plastic front panel NEMA 4/12 which meets the toughest industrial and environmental protection standards

It is a full-function PC-base system with a 10.4" VGA (640 x 480) /12.1" SVGA (800 x 600) color TFT hi-brightness, long-life time LCD display, and compact with different control modules via a 50-pin SCSI cable. The compact dimensions are ideal for automation applications when the installation space is critical.

These PCs are characterized by their space saving, flexible selection of control boxes. AMB-2000/2020 is heavy-duty steel chassis with a sealed plastic front panel meets the toughest industrial and environmental standards. All the controls and connectors are placed on the rear panel, you can connect the panel PCs to other devices via them.

1.2 Specifications

General

- **Construction:** Heavy-duty aluminum chassis & NEMA 4/12 plastic or aluminum front panel
- **Disk drive housing:**
a 3.5" HDD or a 2.5" HDD, Slim CD-ROM
or a 2.5" HDD, Slim FDD.
- **Dimensions(AMB-2000):** 306(W) x 228(H) x 95mm(D)
- **Dimensions(AMB-2020):** 330(W) x 255(H) x 93mm(D)
- **Gross Weight:** 6.0 Kg

Environmental

- **Operating temperature:** 0° to 50°
- **Storage temperature:** -20° to 60°
- **Relative humidity:** 5 to 95%, non-condensing
- **Altitude:** 10,000 ft. (3000 meters)
- **Vibration:**
5 to 17Hz, 0.1" double-amplitude displacement
17 to 500 Hz, 1.5G peak to peak
- **Shock:** 10G-peak acceleration (11-msec. duration)
- **Safety:** meets UL/CSA/TUV
- **EMI:** FCC/CE Class A

Rear View picture

- NEMA 4/12 plastic front panel
- Outside connectors
- Drive bay
- 30 CFM cooling fan
- Power switch
- Power inlet & fuse

Features

AMB-2000 (10.4"LCD + ACS-2300 Control Box)

- 10.4" VGA color TFT LCD display
- Heavy-duty steel chassis and NEMA 4/12 compliant plastic front panel
- All-in-one SBC, NS Geode 233MHz
- Four 16C550 RS-232C port, one RS-232C port can be set as RS-422/485 also
- Disk Driver Space for CD-ROM, FDD and HDD
- DiskOnChip flash disk socket
- PC/104 expansion connector

AMB-2020 (12.1"LCD + ACS-2300 Control Box)

- 12.1" SVGA color TFT LCD display
- Heavy-duty steel chassis and NEMA 4/12 compliant plastic front panel
- All-in-one SBC, MediaGX 233MHz
- Four 16C550 RS-232C port, one RS-232C port can be set as RS-422/485 also
- Disk Driver Space for CD-ROM, FDD and HDD
- DiskOnChip flash disk socket
- PC/104 expansion connector

Specifications

AMB-2000 (10.4"LCD + ACS2300 Control Box)

- **Construction:** Heavy-duty steel chassis & NEMA 4/12 plastic front panel.
- **CPU:** MediaGX 233MHz
- **Memory:** 32M DRAM
- **Display:** 10.4" VGA (640 x 480) TFT color LCD
- **LCD/CRT controller:**
 - NS Cx5530 Chipset
 - UMA supports up to 2.5MB display memory
- **Network (LAN):** Realtek RTL8139B 10/100 Base-T Ethernet controller
- **I/O ports:**
 - 4 serial ports: three RS-232, one RS-232/422/485
 - 1 parallel port (support ECP/EPP)
 - 1 keyboard port
 - 1 PS/2 mouse interface
- **Disk Driver Housing:** 3.5"HDD or 2.5"HDD and 3.5"FDD or 2.5"HDD and Slim-size CD-ROM
- **USB connector:** Dual USB ports onboard
- **Expansion:** PC/104 connector
- **Mounting:** Panel mount or Wall mount (ACS-2300 Control Box only, optional)
- **Power supply:** Universal 70W switching power supply

AMB-2020 (12.1”LCD + ACS2300 Control Box)

- **Construction:** Heavy-duty steel chassis & NEMA 4/12 plastic front panel.
- **CPU:** MediaGX 233MHz
- **Memory:** 32M DRAM
- **Display:** 12.1” SVGA (800 x 600) TFT color LCD
- **LCD/CRT controller:**
NS Cx5530 Chipset
UMA supports up to 2.5MB display memory
- **Network (LAN):** Realtek RTL8139B 10/100 Base-T Ethernet controller
- **I/O ports:**
4 serial ports: three RS-232, one RS-232/422/485
1 parallel port (support ECP/EPP)
1 keyboard port
1 PS/2 mouse interface
- **Disk Driver Housing:** 3.5”HDD or 2.5”HDD and 3.5”FDD or 2.5”HDD and Slim-size CD-ROM
- **USB connector:** Dual USB ports onboard
- **Expansion:** PC/104 connector
- **Mounting:** Panel mount or Wall mount (ACS-2300 Control Box only, optional)
- **Power supply:** Universal 70W switching power supply

Power Supply Selection Table

Mode	Input voltage	Max. Output Current		
		+5V	+12V	-12V
Universal/70W	85-265VAC	12A	2.5A	0.3A
24VDC/70W	10-30VDC	12A	2.5A	0.3A

1.3 Touchscreen (Optional)

- **Type:** 4-wire (10.4”), 8-wire (12.1”) analog resistive
- **Resolution:** Continuous
- **Light transmission:** 72% (surface meets ASTM-D-3363-92A standard.)
- **Operating pressure:** 30-45 grams for finger, 10 grams for stylus pen. Contact bounce < 10ms
- **Controller:** RS-232 interface
- **Power consumption:** +5V @200mA
- **OS support:** MS DOS, Windows 3.1, Windows 95, Windows 98, Windows NT.

1.4 Order Information

AMB-2000HT:

10.4" Modular system Industrial Panel PC

AMB-2000HTT:

AMB-2000HT touchscreen

AMB-2020HT:

12.1" Modular system Industrial Panel PC

AMB-2020HTT:

AMB-2020HT touchscreen

1.5 LCD Specifications

Model	AMB-2000HT	AMB-2020HT
Display type	TFT color LCD	TFT color LCD
Size (diagonal)	10.4"	12.1"
Number of Pixels	640(W) x 480(H)	800(W) x 600(H)
Dot size (mm x mm)	0.33(W) x 0.33(H)	0.3075(W) x 0.3075
Contrast ratio	150	250
View angle (Horizontal)	90°	120°
View angle (Vertical)	50°	100°
Luminance (cd/m ²)	200	250
LCD model	NEC NL6448AC33-18	Toshiba LTM12C289
Operating Temperature	0 ~ 50 °C	0 ~ 50 °C
Backlight Life-time (Hrs)	25,000	25,000

1.6 Dimensions

AMB-2000HT

(mm)

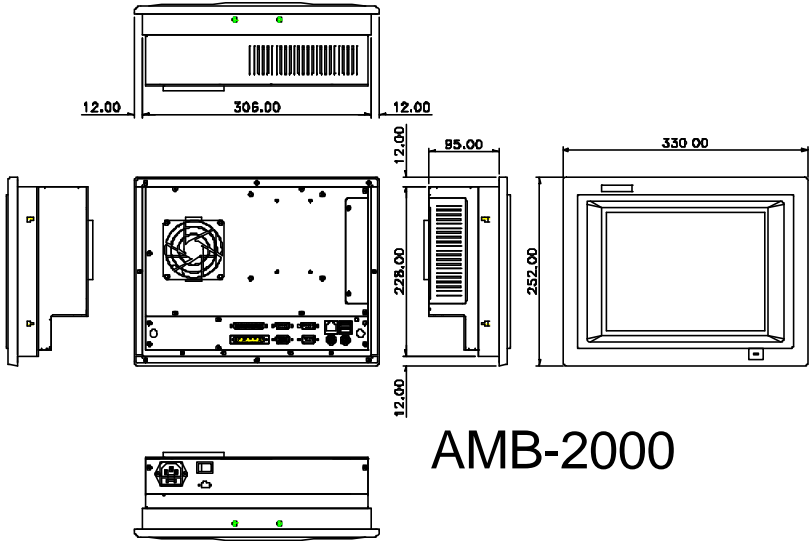

AMB-2000

Cutout (suggestion)

The AMB-2000 series will stand on a shelf or a table or you can mount it into a panel. Cutout panel dimensions are the following:

(mm)

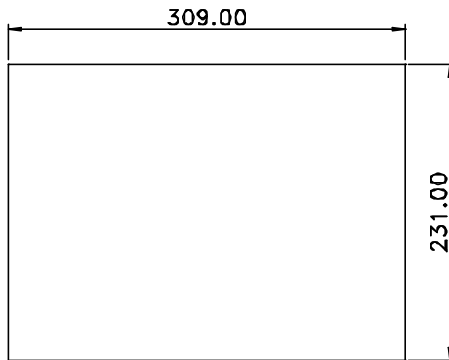

AMB-2000

AMB-2020HT

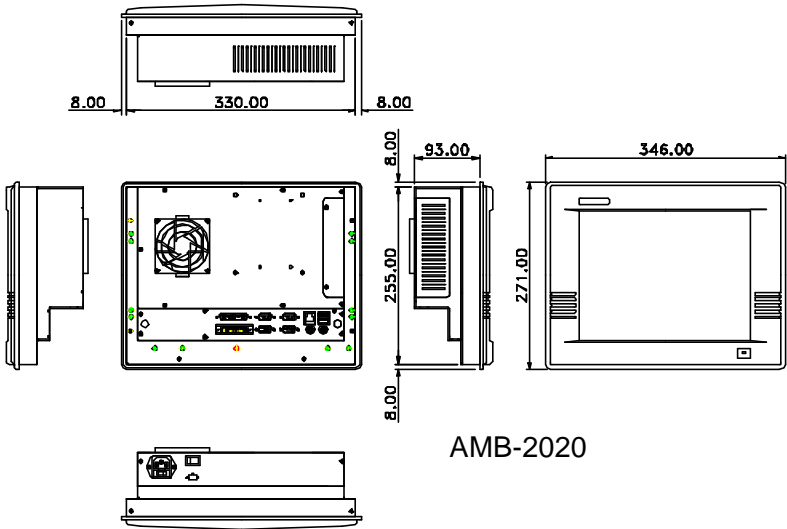

Cutout (suggestion)

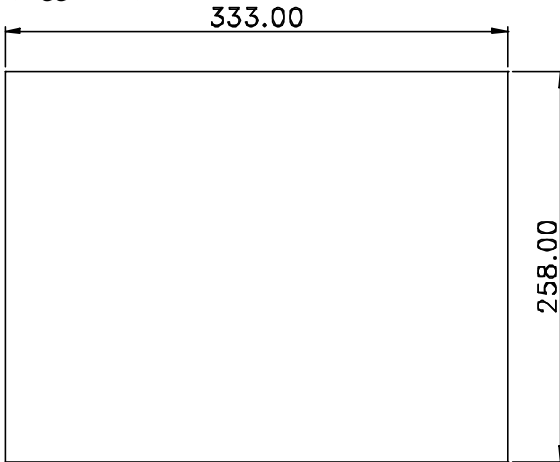

1.7 Panel Mounting

This display panels can be placed on a shelf or table, or mounted onto a control panel. To mount them onto a control panel you need a kind of mounting kits, which you will find in the accessory box. Take the mounting steps described here below:

1. Set the display panel within the aperture in your control panel
2. Slide the mounting kits into the slots on the chassis cover
3. Tighten the bolt in the kits until the display panel is firmly secured to the control

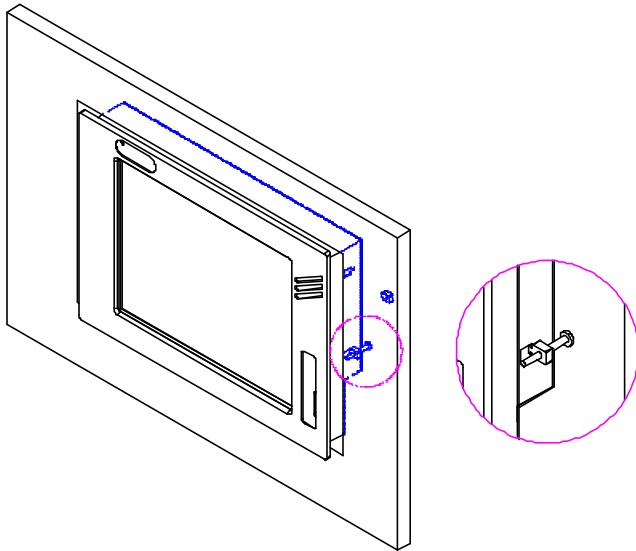

PANEL MOUNTING

1.8 Packing List

Then you should also check if the package contains the following items. You should contact your dealer immediately if any of these items are missing or damaged

- One series industrial MMI panel PC with flat panel display
- Disk for AMB-2000/2020 series user's manual
- Utility & Driver Disks: 3Pcs
 - VGA & Sound Driver for Windows 95/ 98/ NT4.0
 - REALTEK8139 Driver Disk 1
 - REALTEK8139 Driver Disk 2
- Accessory
 - Plane for extension solution
 - Power cable for HDD & FDD
 - Screws bag
 - SCSI Cable (1M)
 - Power cord (1.8 M)
 - Assembly mounting parts

If any of their items are missing or damaged, contact your distributor or sales representative immediately.

2

Chapter 2 The SBC Board MBC-4860

This manual is designed to give you information on the MBC-4860 embedded board. It is divided into the following sections:

<u>2.1</u>	<u>Description</u>	16
<u>2.2</u>	<u>Features</u>	17
<u>2.3</u>	<u>Specifications</u>	18
<u>2.4</u>	<u>Intelligence</u>	20
<u>2.5</u>	<u>Board Dimensions</u>	21

2.1 Description

The MBC-4860 is an Embedded Little Board based on Cyrix CX5530 chipset and is designed for a the Cyrix MediaGXLV processor. With one memory bank on board, up to 128MB of SDRAM can be configured.

The Cyrix MediaGXLV™ MMX™ enhanced processor is an advanced 64-bit x86 compatible processor offering high performance, fully accelerated 2D graphics, a 64-bit synchronous DRAM controller and a PCI bus controller, all on a single chip. In addition to the advanced CPU features, a full-function graphics accelerator provides pixel processing and rendering functions.

A separate on-chip video buffer enables >30FPS MPEG1 video playback when used together with the Cx5530™ chip. Graphics and system memory accesses are supported by a tightly-couple synchronous DRAM (SDRAM memory controller. This tightly couple memory sybssystem eliminates the need for an external L2 cache.

The MediaGXLV processor includes Cyrix's Virtual System Architecture™ (VSA™) enabling Xpress-GRAPHICS™ and XpressAUDIO™ as well as generic emulation capabilities. Software handler routines for XpressGRAPHICS and XpressAUDIO are included in the BIOS and provide compatible VGA and 16-bit industry standard audio emulation. XpressAUDIO technology eliminates much of the hardware traditionally associated with audio functions.

2.2 Features

- Processor: Cyrix MediaGXLV MMX™ ENHANCED
- Chipset: Cyrix Cx5530
- Memory: Up to 128MB in SDRAM
- VGA: Support XpressGRAPHICS™ and integrated on the process
- Ethernet: Realtek RTL8139B 10/100Mbps Ethernet controller
- High speed bi-directional SPP/ECP/EPP parallel port
- Four serial ports (three RS-232, one RS-232/422/485)
- PC/104 connector

2.3 Specifications

- **Processor Socket:** ZIF socket for Cyrix MediaGXLV
- **Processor:** Cyrix MediaGXLV MMX ENHANCED, up to 300MHz
- **Chipset:** Cyrix Cx5530
- **L1 Cache:** 16KB unified L1 cache
- **Memory:** Up to 128MB SDRAM
- **BIOS:** Award BIOS, PnP support
 - FLASH EEPROM (256KB) for BIOS update
 - ISA Plug and Play (PnP) extension
 - Power management
- **Multi I/O:** Winbond 83877TF and NS PC97317
- **Parallel Port:** One high-speed parallel port, SPP/EPP/ECP mode
- **Serial Port:** Four 16550 UART compatible RS232/422/485 ports
- **Enhanced IDE:** Two Bus Mastering EIDE mode, up to 4 devices; two EIDE interfaces for up to 4 devices; supports PIO Mode 3/4 or Ultra DMA/33 IDE Hard Disk, ATAPI CD-ROM, and LS-120.

- **FDD Interface:** Two floppy drives; supports 360KB, 720KB, 1.2MB, 1.44MB and 2.88MB formats
- **USB Interface:** Two USB connectors, compliant with USB Specification Rev. 1.0
- **Green Function:** Power management via BIOS, activated through mouse/keyboard movement
- **Keyboard/Mouse Connector:** PS/2 type connectors
- **VGA Display:**
 - SVGA for CRT & Panel
 - 15-pin connector
 - 1024x768(High Color) resolution on board
 - 2.5MB shared memory
 - LCD panel supports monochrome, color TFT
 - Simultaneous VGA and panel display
 - 15Pin CRT Connector
- **Environmental and Mechanical:**
 - **Temperature:** 0°C to 60°C
 - **Humidity:** 5% to 95%
 - **Dimensions:** 210mm x 170mm (7.99" x 5.75")

2.4 Intelligence

- **CPU Slow Down:** When system overheat is detected, CPU slows down to prevent CPU damage. The CPU speed is restored when temperature falls to a safe level. System overheat is usually caused by malfunctioning of the CPU or system fan.
- **Virus Write Protection:** New-generation viruses can destroy data on storage media, as well as BIOS data. The MBC-4860 is designed to work with the BIOS and flash EPROM to disable write permission until the system initialization is completed upon boot-up.
- **Temperature Monitoring and Alert:** A sensor for the CPU temperature on the MBC-4860 monitors the CPU temperature and alerts the user through the speaker when temperature exceeds the safe heat level.
- **Year 2000 Compliant BIOS:** The onboard Award BIOS is YK2 compliant and will pass software applications that have the tendency to invoke INT1AH function 04H such as year2000.exe utility released by NSTL.

2.5 Board Dimensions

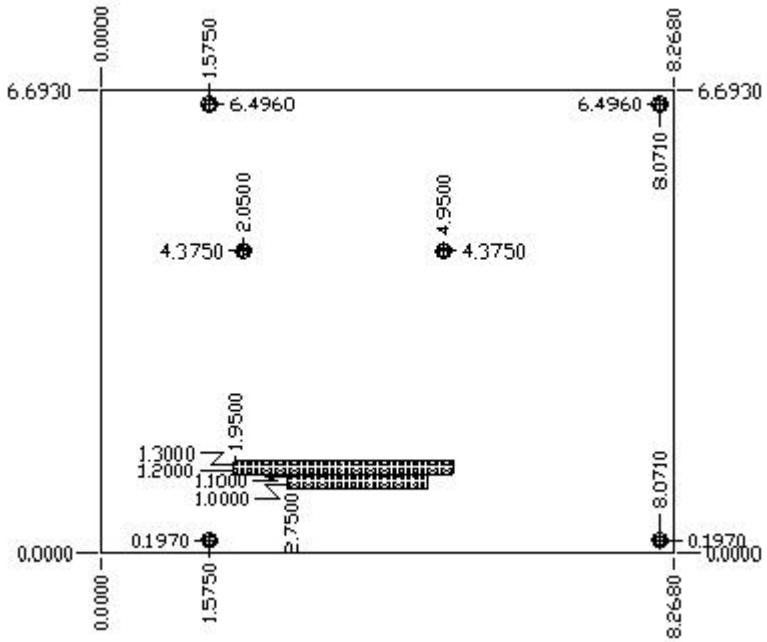

3

Chapter3 MBC-4860 Installations

This chapter provides information on how to use the jumpers and connectors on the MBC-4860 in order to set up a workable system. The topics covered are:

<u>3.1</u>	<u>CPU Installation</u>	23
<u>3.2</u>	<u>Memory Installation</u>	24
<u>3.3</u>	<u>Jumpers on the MBC-4860</u>	25
<u>3.4</u>	<u>Connectors on the MBC-4860</u>	31

3.1 CPU Installation

The MBC-4860 Embedded Little Board supports a ZIF processor socket for Cyrix MediaGXLV processors.

To install the processor on the ZIF socket, make sure the notch on the corner of the processor corresponds with the notch on the inside of the socket.

After you have installed the processor into the ZIF socket, check if the jumpers for the CPU frequency is correct.

NOTE: *Ensure that the CPU heat sink and the CPU top surface are in total contact to avoid CPU overheating problem that would cause your system to hang or be unstable.*

3.2 Memory Installation

The MBC-4860 Embedded Little Board supports one 168-pin DIMM socket for a maximum total memory of 128MB in 66MHz or 100MHz frequency. The SDRAM sizes can be 16MB, 32MB, 64MB and 128MB. The MBC-4860 optionally comes with 64MB SDRAM on board in place of the DIMM socket.

Installing and Removing DIMMs

To install the DIMM module, locate the memory slot on the MBC-4860 and perform the following steps:

1. Hold the DIMM so that the two keys of the DIMM align with those on the memory slot.
2. Gently push the DIMM in an upright position until the clips of the slot close to hold the DIMM in place when the DIMM touches the bottom of the slot.
3. To remove the DIMM, press the clips with both hands.

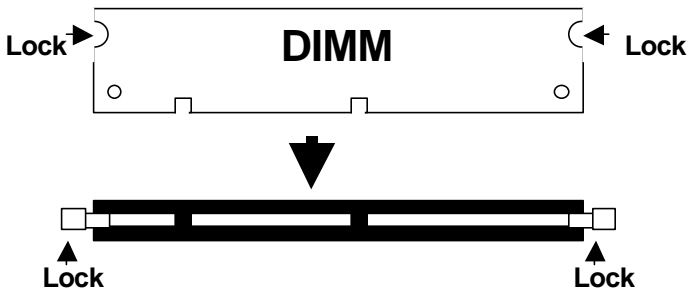

Top View of DIMM Socket

3.3 Jumpers on the MBC-4860

The jumpers on the MBC-4860 allow you to configure your embedded board according to the needs of your applications. If you have doubts about the best jumper configuration for your needs, contact your dealer or sales representative. The following table lists the connectors on MBC-4860 and their respective functions.

Jumper Locations on the MBC-4860.....	26
SW3: CPU Voltage Selector.....	27
U13: CPU Frequency Selector	27
JP10: RS232/422/485 (COM2) Selection.....	28
JP6: LCD Power Setting.....	29
JP12: Clear CMOS.....	29
JP16: DiskOnChip BIOS Expansion Address Select	30
JP14: Reset Button Connector	30

Remarks: The following conventions are used in this section:

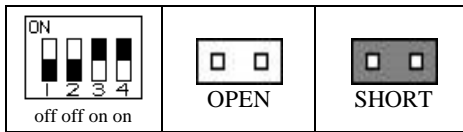



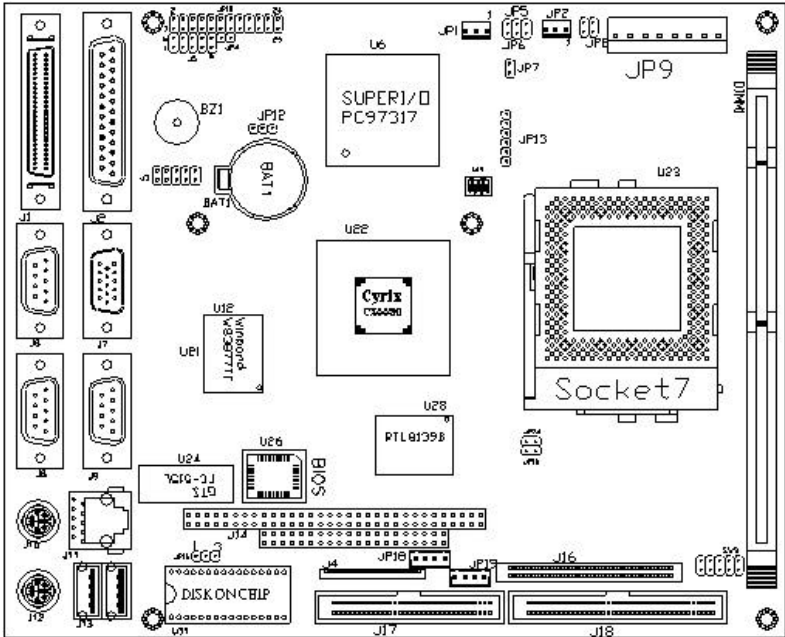

Jumper Locations on the MBC-4860

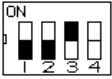

SW3: CPU Voltage Selector

CPU Voltage	SW3 Short Jumpers	CPU Voltage	SW3 Short Jumpers
2.1V	1-2	2.9V	1-2, 7-8
2.2V	3-4	3.0V	3-4, 7-8
2.3V	1-2, 3-4	3.1V	1-2, 3-4, 7-8
2.4V	5-6	3.2V	5-6, 7-8
2.5V	1-2, 5-6	3.3V	1-2, 5-6, 7-8
2.6V	2-4, 5-6	3.4V	3-4, 5-6, 7-8
2.7V	3-4, 5-6	3.5V	1-2, 3-4, 5-6, 7-8
2.8V	1-2, 3-4, 5-6		

U13: CPU Frequency Selector

CPU Frequency	U13 Switch
200MHz	 off on off xx
233MHz	 off off on xx
266MHz	 off off off xx
300MHz	 on off on xx
333MHz	 on on off xx

JP10: RS232/422/485 (COM2) Selection

COM1 is fixed for RS-232 use only.

COM2 is selectable for RS232, RS-422 and RS-485.

The following table describes the jumper settings of this connector.

COM2 Function	RS-232	RS-422	RS-485
Jumper Setting (pin closed)	all jumpers open	1-2 3-4 5-6 7-8 11-12 15-16 17-18 19-20 23-24	1-2 3-4 5-6 7-8 9-10 11-12 13-14 15-16 17-18 19-20 21-22
Jumper Illustration			

JP6: LCD Power Setting

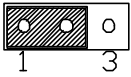
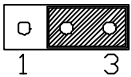
JP6	Setting	Function
	Pin 1-2 Short/Closed	5V
	Pin 2-3 Short/Closed	3.3V

JP12: Clear CMOS

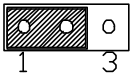
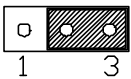
JP12	Setting	Function
	Pin 1-2 Short/Closed	Clear CMOS
	Pin 2-3 Short/Closed	Normal

Follow the steps below to clear CMOS data.

1. Disconnect the AC power cord.
2. Short JP12 (1-2) and wait for 3 seconds.
3. Short JP12 (2-3) and replace the AC power cord.
4. Turn on the system.

JP16: DiskOnChip BIOS Expansion Address Select

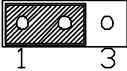
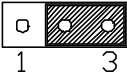
JP16	Address
 <p>Diagram of JP16 jumper with pins 1 and 3 shaded. Pin 1 is on the left and pin 3 is on the right. The area between them is shaded with diagonal lines.</p>	D0000-D7FFF
 <p>Diagram of JP16 jumper with pins 2 and 3 shaded. Pin 1 is on the left and pin 3 is on the right. The area between pins 2 and 3 is shaded with diagonal lines.</p>	D8000-DFFFF (default)

JP14: Reset Button Connector

JP14 is a 2-pin headers for the reset button used to restart the system without turning off the power and then on again.

3.4 Connectors on the MBC-4860

The connectors on the MBC-4860 allows you to connect external devices such as keyboard, floppy disk drives, hard disk drives, printers, etc. The following table lists the connectors on MBC-4860 and their respective functions.

Connector Locations on the MBC-4860	32
JP1, JP2: Fan Power Connectors.....	33
J2: Parallel Port Connector.....	33
J4, J17: Floppy Drive Connectors	34
J6, J8, J9: COM1/2/3 Serial Ports	35
J7: VGA Port Connector	35
JP7: Power Switch Connector	36
JP9: Power Connector.....	36
J10: PS/2 Keyboard Connector	36
J11: RJ45 Connector	36
J12: PS/2 Mouse Connector	37
JP13: IrDA Connector	37
J13: USB Connector	37
JP15: HDD LED.....	37
J14, J15: PC-104 Connector	39
J18, J16: EIDE Connectors	40
JP18, JP19: DC-Out Connectors.....	41

Connector Locations on the MBC-4860

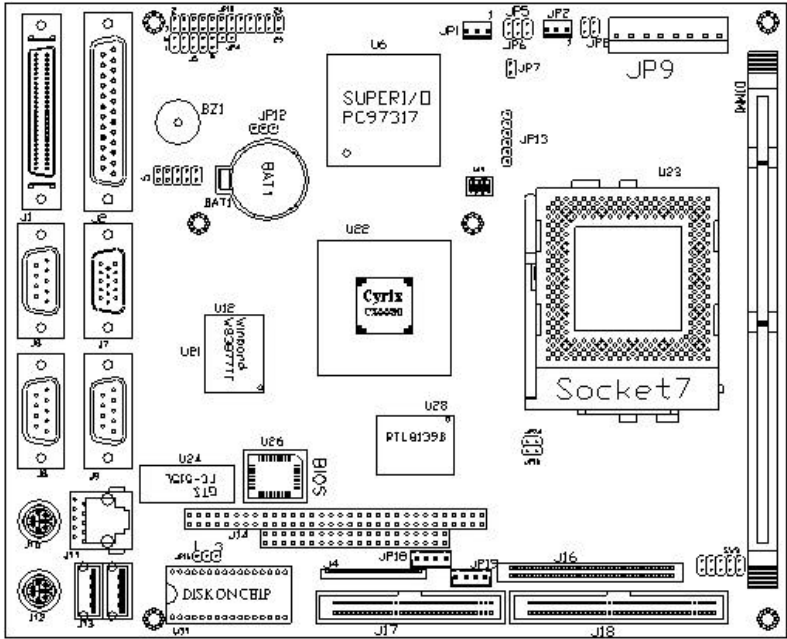

JP1, JP2: Fan Power Connectors

JP1 and JP2 are 3-pin header power connectors for 12V fans.

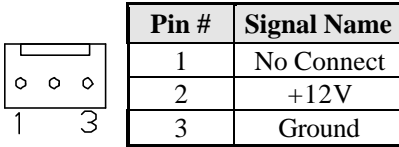

J2: Parallel Port Connector

J2 Parallel Port Connector is a DB-25 external connector. The following table describes the pin-out assignments of this connector.

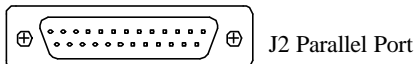

Signal Name	Pin #	Pin #	Signal Name
Line printer strobe	1	14	AutoFeed
PD0, parallel data 0	2	15	Error
PD1, parallel data 1	3	16	Initialize
PD2, parallel data 2	4	17	Select
PD3, parallel data 3	5	18	Ground
PD4, parallel data 4	6	19	Ground
PD5, parallel data 5	7	20	Ground
PD6, parallel data 6	8	21	Ground
PD7, parallel data 7	9	22	Ground
ACK, acknowledge	10	23	Ground
Busy	11	24	Ground
Paper empty	12	25	Ground
Select	13	N/A	N/A

J4, J17: Floppy Drive Connectors

J4 (26-pin) and J17 (34-pin) are the floppy drive connectors on the MBC-4860. The following table shows its pin-out assignments.



J4
26-pin

Signal Name	Pin #	Pin #	Signal Name
Vcc	1	2	Index
Vcc	3	4	Drive select 0
Vcc	5	6	Diskette change
N.C.	7	8	N.C.
N.C.	9	10	Motor enable 0
N.C.	11	12	Direction
RM/LC	13	14	Step
Ground	15	16	Write data
Ground	17	18	Write gate
Ground	19	20	Track 00
Ground	21	22	Write protect
Ground	23	24	Read data
Ground	25	26	Side 1 select

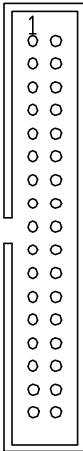

J4
34-pin

Signal Name	Pin #	Pin #	Signal Name
Ground	1	2	RM/LC
Ground	3	4	No connect
Ground	5	6	No connect
Ground	7	8	Index
Ground	9	10	Motor enable 0
Ground	11	12	Drive select 1
Ground	13	14	Drive select 0
Ground	15	16	Motor enable 1
Ground	17	18	Direction
Ground	19	20	Step
Ground	21	22	Write data
Ground	23	24	Write gate
Ground	25	26	Track 00
Ground	27	28	Write protect
Ground	29	30	Read data
Ground	31	32	Side 1 select
Ground	33	34	Diskette change

J6, J8, J9: COM1/2/3 Serial Ports

J6, J8 and J9 DB-9 connectors are the COM1, COM2, and COM3 serial ports of MBC-4860. The following table shows the pin-out assignments of these connectors.

Signal Name	Pin #	Pin #	Signal Name
DCD, Data carrier detect	1	6	DSR, Data set ready
RXD, Receive data	2	7	RTS, Request to send
TXD, Transmit data	3	8	CTS, Clear to send
DTR, Data terminal ready	4	9	RI, Ring indicator
GND, ground	5	10	Not Used

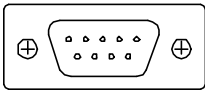

J6, J8, J9 Serial Ports

J7: VGA Port Connector

J7 is a DB-15 VGA connector. The following table shows the pin-out assignments of this connector.

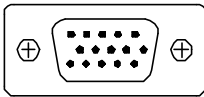

Signal Name	Pin #	Pin #	Signal Name
Red	1	2	Green
Blue	3	4	N.C.
GND	5	6	GND
GND	7	8	GND
N.C.	9	10	GND
N.C.	11	12	N.C.
HSYNC	13	14	VSYNC
NC	15		

JP7: Power Switch Connector

JP7 is a 2 pin header for the external power button.

JP9: Power Connector

JP9 power connector has the following pin assignments.

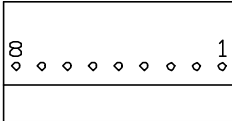

Pin #	Signal Name
1	+5V
2	+5V
3	+5V
4	Ground
5	Ground
6	Ground
7	+12V
8	-12V

J10: PS/2 Keyboard Connector

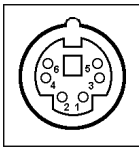

Pin #	Signal Name
1	Keyboard data
2	N.C.
3	GND
4	5V
5	Keyboard clock
6	N.C.

J11: RJ45 Connector

The RJ45 Ethernet connector supports 10/100Mbps data transfer rates. The figure below shows the pin out assignments of this connector.

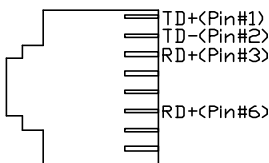

J12: PS/2 Mouse Connector

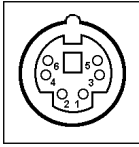

J17

Pin #	Signal Name
1	Mouse data
2	N.C.
3	GND
4	5V
5	Mouse clock
6	N.C.

JP13: IrDA Connector

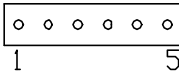

Pin #	Signal Name
1	Vcc
2	No Connect
3	RIR RX
4	RIRTX
5	RFIRPX

J13: USB Connector

J13 is the standard USB external connector consisting of two ports. USB support allows connections of up to 64 plug and play external peripherals per channel. The following table shows the pin outs of these ports.

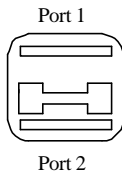

Pin #	Signal Name
1	Vcc
2	USB-
3	USB+
4	Ground

JP15: HDD LED

JP15 is a 2-pin headers connecting to the HDD LED that shows any HDD activity.

J14, J15: PC-104 Connector

J14 and J15 are dual-in-line pin headers that support PC-104 modules. J14 consists of 64 pins and J15 has 40 pins. The following table shows the their pin assignments.

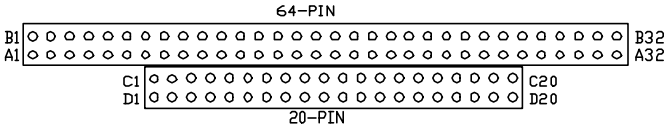

J14				J15			
Pin	Signal Name	Pin	Signal Name	Pin	Signal Name	Pin	Signal Name
A1	IOCHK	B1	GND	C1	GND	D1	GND
A2	D7	B2	REST	C2	SBHE	D2	MEMCS16
A3	D6	B3	VCC	C3	NC	D3	IOCS16
A4	D5	B4	IRQ9	C4	NC	D4	IRQ10
A5	D4	B5	-5V	C5	NC	D5	IRQ11
A6	D3	B6	DRQ2	C6	NC	D6	IRQ12
A7	D2	B7	-12V	C7	LA19	D7	IRQ15
A8	D1	B8	OVS	C8	LA18	D8	IRQ14
A9	D0	B9	+12V	C9	LA17	D9	DACK0
A10	IOCHRDY	B10	GND	C10	MEMR	D10	DRQ0
A11	AEN	B11	SMEMW	C11	MEMW	D11	DACK5
A12	A19	B12	SMEMR	C12	D8	D12	DRQ5
A13	A18	B13	IOW	C13	D9	D13	DACK6
A14	A17	B14	IOR	C14	D10	D14	DRQ6
ZA15	A16	B15	DACK3	C15	D11	D15	DACK7
A16	A15	B16	DRQ3	C16	D12	D16	DRQ7
A17	A14	B17	DACK1	C17	D13	D17	VCC
A18	A13	B18	DRQ1	C18	D14	D18	MASTER
A19	A12	B19	REFRESH	C19	D15	D19	GND
A20	A11	B20	CLK	C20	KEY PIN	D20	GND
A21	A10	B21	IRQ7				
A22	A9	B22	IRQ6				
A23	A8	B23	IRQ5				
A24	A7	B24	IRQ4				
A25	A6	B25	IRQ3				
A26	A5	B26	DACK2				
A27	A4	B27	TC				
A28	A3	B28	BALE				
A29	A2	B29	VCC				
A30	A1	B30	OSC				
A31	A0	B31	GND				
A32	GND	B32	GND				

J18, J16: EIDE Connectors

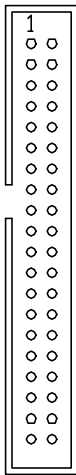

J18
IDE1
40-pin

Signal Name	Pin #	Pin #	Signal Name
Reset IDE	1	2	Ground
Host data 7	3	4	Host data 8
Host data 6	5	6	Host data 9
Host data 5	7	8	Host data 10
Host data 4	9	10	Host data 11
Host data 3	11	12	Host data 12
Host data 2	13	14	Host data 13
Host data 1	15	16	Host data 14
Host data 0	17	18	Host data 15
Ground	19	20	Key
DRQ0	21	22	Ground
Host IOW	23	24	Ground
Host IOR	25	26	Ground
IOCHRDY	27	28	Host ALE
DACK0	29	30	Ground
IRQ14	31	32	No connect
Address 1	33	34	No connect
Address 0	35	36	Address 2
Chip select 0	37	38	Chip select 1
Activity	39	40	Ground

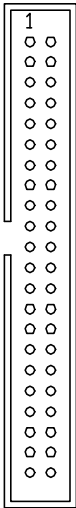

J16
IDE2
44-pin

Signal Name	Pin #	Pin #	Signal Name
Reset IDE	1	2	Ground
Host data 7	3	4	Host data 8
Host data 6	5	6	Host data 9
Host data 5	7	8	Host data 10
Host data 4	9	10	Host data 11
Host data 3	11	12	Host data 12
Host data 2	13	14	Host data 13
Host data 1	15	16	Host data 14
Host data 0	17	18	Host data 15
Ground	19	20	Key
DRQ0	21	22	Ground
Host IOW	23	24	Ground
Host IOR	25	26	Ground
IOCHRDY	27	28	Host ALE
DACK1	29	30	Ground
MIRQ0	31	32	No connect
Address 1	33	34	No connect
Address 0	35	36	Address 2
Chip select 0	37	38	Chip select 1
Activity	39	40	Ground
Vcc	41	42	Vcc
Ground	43	44	N.C.

JP18, JP19: DC-Out Connectors

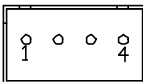

Pin #	Signal Name
1	+12V
2	Ground
3	Ground
4	+5V

4

Chapter4 Hardware and Installation

This chapter provides information on how to install the hard ware and location on the AMB-2000 series panel PCs in order to set up a workable system. The topics covered are:

<u>Exploded Diagram</u>	43
<u>Cooling Fan Replacement</u>	44
<u>Install a 3.5" HDD</u>	45
<u>Install a Slim CD-Rom and 2.5" HDD</u>	46
<u>Install a Slim FDD and 2.5" HDD</u>	47

Exploded Diagram

The Award BIOS (Basic Input/Output System) installed in your system's ROM supports NS Geode processors in a standard IBM-AT compatible I/O system. The BIOS provides critical low-level support for standard devices such as disk drives, parallel port and serial ports. It also adds virus and password protection, as well as special support for detailed fine-tuning of the chipset controlling the entire system.

Cooling Fan Replacement

To Service or replace the cooling fan need to remove the rear protective cover and use this diagram as a guide when assembling and disassembling your cooling fan

Install a 3.5” HDD

To installing a 3.5”HDD into AMB-2000HT/2020HT

1. Remove the rear protective cover
2. Place the HDD in the appropriate location and tighten the screws
3. Connect the cable form HDD to the PC board (CN21).

Install a Slim CD-Rom and 2.5” HDD

Install a Slim FDD and 2.5” HDD

5

Chapter5 BIOS Configuration

This chapter describes the different settings available in the Award BIOS that comes with the MBC-4860 embedded board. The topics covered in this chapter are as follows:

BIOS Introduction	49
BIOS Setup.....	49
Standard CMOS Setup.....	51
BIOS Features Setup	54
Chipset Features Setup.....	57
Power Management Setup	58
PNP/PCI Configuration.....	60
Load BIOS Defaults	61
Load Setup Defaults	62
Integrated Peripherals	63
Supervisor / User Password.....	66
IDE HDD Auto Detection.....	67
Save & Exit Setup	68
Exit Without Saving.....	68

BIOS Introduction

The Award BIOS (Basic Input/Output System) installed in your system's ROM supports NS Geode processors in a standard IBM-AT compatible I/O system. The BIOS provides critical low-level support for standard devices such as disk drives, parallel port and serial ports. It also adds virus and password protection, as well as special support for detailed fine-tuning of the chipset controlling the entire system.

BIOS Setup

The Award BIOS provides a Setup utility program for specifying the system configurations and settings. The BIOS ROM of the system stores the Setup utility. When you turn on the computer, the Award BIOS is immediately activated. Pressing the key immediately allows you to enter the Setup utility. If you are a little bit late pressing the key, POST (Power On Self Test) will continue with its test routines, thus preventing you from invoking the Setup. If you still wish to enter Setup, restart the system by pressing the "Reset" button or simultaneously pressing the <Ctrl>, <Alt> and <Delete> keys. You can also restart by turning the system off and back on again. The following message will appear on the screen:

Press to Enter Setup

In general, you press the arrow keys to highlight items, <Enter> to select, the <PgUp> and <PgDn> keys to change entries, <F1> for help and <Esc> to quit.

When you enter the Setup utility, the Main Menu screen will appear on the screen. The Main Menu allows you to select from various setup functions and exit choices.

ROM PCI/ISA BIOS
 CMOS SETUP UTILITY
 AWARD SOFTWARE, INC.

STANDARD CMOS SETUP	INTEGRATED PERIPHERALS
BIOS FEATURES SETUP	SUPERVISOR PASSWORD
CHIPSET FEATURES SETUP	USER PASSWORD
POWER MANAGEMENT SETUP	IDE HDD AUTO DETECTION
PNP/PCI CONFIGURATION	SAVE & EXIT SETUP
LOAD BIOS DEFAULTS	EXIT WITHOUT SAVING
LOAD SETUP DEFAULTS	↑ ↓ → ← : Select Item
ESC : Quit	(Shift) F2 : Change Color
F10 : Save & Exit Setup	(Shift) F2 : Change Color

The section below the setup items of the Main Menu displays the control keys for this menu. At the bottom of the Main Menu just below the control keys section, there is another section that displays information about the currently highlighted item in the list.

NOTE: *If your computer cannot boot after making and saving system changes with Setup, the Award BIOS supports an override to the CMOS settings that resets your system to its default.*

We strongly recommend that you avoid making any changes to the chipset defaults. These defaults have been carefully chosen by both Award and your system manufacturer to provide the absolute maximum performance and reliability.

Standard CMOS Setup

“Standard CMOS Setup” choice allows you to record some basic hardware configurations in your computer system and set the system clock and error handling. If the Embedded Little Board is already installed in a working system, you will not need to select this option. You will need to run the Standard CMOS option, however, if you change your system hardware configurations, the onboard battery fails, or the configuration stored in the CMOS memory was lost or damaged.

ROM PCI/ISA BIOS
STANDARD CMOS SETUP
AWARD SOFTWARE, INC.

Date (mm:dd:yy) : Mon , Aug 19 1996								
Time (hh:mm:ss) : 00 : 00 : 00								
HARD DISKS	TYPE	SIZE	CYLS	HEAD	PRECOMP	LANDZ	SECTOR	MODE
Primary Master	Auto	0	0	0	0	0	0	Auto
Primary Slave	None	0	0	0	0	0	0	----
Secondary Master	None	0	0	0	0	0	0	----
Secondary Slave	None	0	0	0	0	0	0	----
Drive A	: 1.44M, 3.5in				Base Memory		: 640K	
Drive B	: None				Extended Memory		: 15360K	
Video	: EGA / VGA				Other Memory		: 384K	
Halt On	: All Errors				Total Memory		: 16384K	
ESC : Quit			↑ ↓ → ← : Select			Item PU / PD / + / - : Modify		
F1 : Help			(Shift) F2 : Change Color					

At the bottom of the menu are the control keys for use on this menu. If you need any help in each item field, you can press the <F1> key. It will display the relevant information to help you. The memory display at the lower right-hand side of the menu is read-only. It will adjust automatically according to the memory changed. The following describes each item of this menu.

Date

The date format is:

Day : Sun to Sat
Month : 1 to 12
Date : 1 to 31
Year : 1994 to 2009

To set the date, highlight the “Date” field and use the PageUp/ PageDown or +/- keys to set the current time.

Time

The time format is: **Hour : 00 to 23**
Minute : 00 to 59
Second : 00 to 59

To set the time, highlight the “Time” field and use the <PgUp>/ <PgDn> or +/- keys to set the current time.

Primary HDDs / Secondary HDDs

The onboard PCI IDE connectors provide Primary and Secondary channels for connecting up to four IDE hard disks or other IDE devices. Each channel can support up to two hard disks; the first is the “Master” and the second is the “Slave”.

To enter the specifications for a hard disk drive, you must select first a “Type”. There are 45 predefined types and 4 user definable types are for Enhanced IDE BIOS. Type 1 to 45 are predefined. Type “User” is user-definable. For the Primary Master/Slave as well as Secondary Master/Slave, you can select “Auto” under the TYPE and MODE fields. This will enable auto detection of your IDE drives and CD-ROM drive during POST.

Press <PgUp>/<PgDn> to select a numbered hard disk type or type the number and press the <Enter> key. The hard disk will not work properly if you enter incorrect information for this field. If your hard disk drive type is not matched or listed, you can use Type User to define your own drive type manually. If you select Type User, related information is asked to be entered to the following items.

CYLS : Number of cylinders
HEAD : Number of read/write heads
PRECOMP : Write precompensation
LANDZ : Landing zone
SECTOR : Number of sectors
SIZE : Automatically adjust according to the configuration
MODE (for IDE HDD only) : Auto
Normal (HD < 528MB)
Large (for MS-DOS only)
LBA (HD > 528MB and supports
Logical Block Addressing)

***NOTE:** The specifications of your drive must match with the drive table. If your hard disk drive type is not matched or listed, you can use Type User to define your own drive type manually.*

Drive A / Drive B

These fields identify the types of floppy disk drive A or drive B that has been installed in the computer. The available specifications are:

360KB 5.25 in.	1.2MB 5.25 in.	720KB 3.5 in.	1.44MB 3.5 in.	2.88MB 3.5 in.
-------------------	-------------------	------------------	-------------------	-------------------

Floppy 3 Mode Support

This is the Japanese standard floppy drive. The standard stores 1.2MB in a 3.5-inch diskette. You have four options to choose:

Disabled	No 3 mode floppy drive installed. (default)
Drive A	Installed 3 mode drive at drive A.
Drive B	Installed 3 mode drive at drive B.
Both	Installed 3 mode drive at drive A and B.

Video

This field selects the type of video display card installed in your system. You can choose the following video display cards:

EGA/VGA	For EGA, VGA, SEGA, SVGA or ZIF monitor adapters.(default)
CGA 40	Power up in 40 column mode.
CGA 80	Power up in 80 column mode.
MONO	For Hercules or MDA, includes high resolution monochrome adapters.

Halt On

This field determines whether or not the system will halt if an error is detected during power up.

No errors	The system boot will not be halted for any error that may be detected.
All errors	Whenever the BIOS detects a non-fatal error, the system will be halted and you will be prompted.
All, But Keyboard	The system boot will not be halted for a keyboard error; it will stop for all other errors.
All, But Diskette	The system boot will not be halted for a disk error; it will stop for all other errors.
All, But Disk/Key	The system boot will not be halted for a keyboard or disk error; it will stop for all other errors.

BIOS Features Setup

This section allows you to configure and improve your system and allows you to set up some system features according to your preference.

ROM / PCI ISA BIOS
BIOS FEATURES SETUP
AWARD SOFTWARE, INC.

Virus Warning	: Disabled	Video BIOS Shadow	: Enabled
CPU Internal Cache	: Enabled	C8000-CBFFF Shadow	: Disabled
		CC000-CFFFF Shadow	: Disabled
Quick Power On Self Test	: Enabled	D0000-D3FFF Shadow	: Disabled
Boot Sequence	: A, C, SCSI	D4000-D7FFF Shadow	: Disabled
Swap Floppy Drive	: Disabled	D8000-DBFFF Shadow	: Disabled
Boot Up Floppy Seek	: Enabled	DC000-DFFFF Shadow	: Disabled
Boot Up Numlock Status	: On		
Boot Up System Speed	: High		
Gate A20 Option	: Fast		
Memory Parity Check	: Enabled		
Typematic Rate Setting	: Disabled		
Typematic Rate (chars/Sec)	: 6		
Typematic Delay (Msec)	: 250	ESC : Quit	↑ ↓ → ← : Select Item
Security Option	: Setup	F1 : Help	PU/PD/+/- : Modify
PCI /VGA Palette Snoop	: Disabled	F5 : Old Values	(Shift) F2 : Color
OS Select For DRAM>64MB	: Non-OS2	F6 : Load BIOS Defaults	
Report No FDD For WIN 95	: Yes	F7 : Load Setup Defaults	

Virus Warning

This item protects the boot sector and partition table of your hard disk against accidental modifications. If an attempt is made, the BIOS will halt the system and display a warning message. If this occurs, you can either allow the operation to continue or run an anti-virus program to locate and remove the problem.

NOTE: Many disk diagnostic programs, which attempt to access the boot sector table, can cause the virus warning. If you will run such a program, disable the Virus Warning feature.

CPU Internal Cache

These items allow you to enable (speed up memory access) or disable the cache function. By default, these items are **Enabled**.

Quick Power On Self Test

This choice speeds up the Power On Self Test (POST) after you power up the system. If it is set to **Enabled**, BIOS will skip some items. By default, this choice is **Enabled**.

Boot Sequence

This field determines the drive that the system searches first for an operating system. The options are:

A, C, SCSI	D, A, SCSI	SCSI, C, A
C, A, SCSI	E, A, SCSI	C only
C, CDROM, A	F, A, SCSI	LS120, C
CDROM, C, A	SCSI, A, C	

The default value is *C, CDROM, A*.

Swap Floppy Drive

This item allows you to determine whether or not to enable the swap Floppy Drive. When enabled, the BIOS swaps floppy drive assignments so that Drive A becomes Drive B, and Drive B becomes Drive A. By default, this field is set to *Disabled*.

Boot Up Floppy Seek

When enabled, the BIOS will seek whether or not the floppy drive installed has 40 or 80 tracks. 360K type has 40 tracks while 760K, 1.2M and 1.44M all have 80 tracks. By default, this field is set to *Enabled*.

Boot Up NumLock Status

This allows you to activate the NumLock function after you power up the system. By default, the system boots up with *NumLock On*.

Boot Up System Speed

This has no function and selects the default system speed (*High*).

Gate A20 Option

This field allows you to select how Gate A20 is worked. The Gate A20 is a device used to address memory above 1 MB. By default, this field is set to *Fast*.

Memory Parity/ECC Check

This field allows you to enable the parity/ECC checking function of the memory module if it is supported. By default, this field is set to *Disabled*.

Typematic Rate Setting

When disabled, continually holding down a key on your keyboard will generate only one instance. When enabled, you can set the two typematic controls listed next. By default, this field is set to *Disabled*.

Typematic Rate (Chars/Sec)

When the typematic rate is enabled, the system registers repeated keystrokes speeds. You can select speed range from 6 to 30 characters per second. By default, this item is set to **6**.

Typematic Delay (Msec)

When the typematic rate is enabled, this item allows you to set the time interval for displaying the first and second characters. By default, this item is set to **250msec**.

Security Option

This field allows you to limit access to the System and Setup. The default value is **Setup**. When you select **System**, the system prompts for the User Password every time you boot up. When you select **Setup**, the system always boots up and prompts for the Supervisor Password only when the Setup utility is called up.

PCI/VGA Palette Snoop

Some display cards that are non-standard VGA may not show colors properly. This field allows you to set whether or not MPEG ISA/VESA VGA Cards can work with PCI/VGA. When this field is enabled, a PCI/VGA can work with an MPEG ISA/VESA VGA card. When this field is disabled, a PCI/VGA cannot work with an MPEG ISA/VESA card.

OS Select for DRAM > 64MB

This option allows the system to access greater than 64MB of DRAM memory when used with OS/2 that depends on certain BIOS calls to access memory. The default setting is **NON-OS/2**.

Report No FDD For WIN 95

This option allows Windows 95 to share with other peripherals IRQ6, which is assigned to a floppy disk drive if the drive is not existing.

Video BIOS Shadow

This item allows you to change the Video BIOS location from ROM to RAM. Video Shadow will increase the video speed.

C8000 - CBFFF Shadow/DC000 - DFFFF Shadow

Shadowing a ROM reduces the memory available between 640KB to 1024KB. These fields determine whether or not optional ROM will be copied to RAM.

Chipset Features Setup

This menu controls the configuration of the embedded board chipset.

ROM PCI/ISA BIOS
CHIPSET FEATURES SETUP
AWARD SOFTWARE INC.

SDRAM Timing Setup	: Auto	16-bit I/O Recovery (CLK)	: 5
		8-bit I/O Recovery (CLK)	: 5
		USB Controller	: Disabled
Multiple Monitor Support	: Enable		
Video Memory Size	: 2.5M		
Flat Panel Status	: Enabled	ESC : Quit	↑ ↓ → ← : Select Item
Flat Panel Resolution	: 800x600	F1 : Help	PU/PD/+/- : Modify (Shift) F2 : Color
		F5 : Old Values	
		F6 : Load BIOS Defaults	
		F7 : Load Setup Defaults	

SDRAM Timing

The SDRAM timing is controlled by the DRAM Timing Registers. The timing type is dependent on the system design. Slower rates may be required in some system designs to support loose layouts or slower memory. When set to *User* the following options are opened for configuration:

SDRAM Clock Ratio	MD High Drive Control
MA/BA High Drive Control	Control High Drive/Slew
Two Clock Address Setup	SDCLK Edge Delay
SDCLK Falling Delay	SDCLK High Drive/Slew
Shift SD CLK	CAS Latency (LTMODE)

Multiple Monitor Support

The default setting for Multiple Monitor Support is *No Onboard*.

Video Memory Size

The default setting of Video Memory Size is *2.5 M*.

Flat Panel Status

The default setting of Flat Panel Status is *Enabled*.

Flat Panel Resolution

The default setting of the flat panel resolution is *800x600*.

16 Bit I/O Recovery (CLK)

This field allows you to select the recovery time allowed for 16 bit I/O.

8 Bit I/O Recovery (CLK)

This field allows you to select the recovery time allowed for 8 bit I/O.

USB Controller

This field allows you to enable or disable the USB controller on board.

Power Management Setup

The Power Management Setup allows you to save energy of your system effectively. It will shut down the hard disk and turn off video display after a period of inactivity.

ROM PCI/ISA BIOS (2A59IM29)
POWER MANAGEMENT SETUP
AWARD SOFTWARE, INC.

Power Management	: Disabled	** Reload Global Timer Events **	
** Timers **		IRQ1 (Keyboard)	: ON
Doze Mode	: Disabled	IRQ3 (COM2)	: OFF
Standby Mode	: Disabled	IRQ4 (COM1)	: OFF
HDD Power Down	: Disabled	IRQ5 (LPT 2)	: OFF
MODEM Use IRQ	: NA	IRQ6 (Floppy Disk)	: OFF
		IRQ7 (LPT 1)	: OFF
Throttle Duty Cycle	: 33.3%	IRQ8 (RTC Alarm)	: OFF
		IRQ9 (IRQ2 Redir)	: OFF
RTC Alarm Function	: Disabled	IRQ10 (Reserved)	: OFF
		IRQ11 (Reserved)	: OFF
		IRQ12 (PS/2 Mouse)	: OFF
		IRQ13 (Coprocessor)	: OFF
		IRQ14 (Hard Disk)	: OFF
		IRQ15 (Reserved)	: OFF
		ESC : Quit	↑ ↓ → ← : Select Item
		F1 : Help	PU/PD/+/- : Modify
		F5 : Old Values	(Shift) F2 : Color
		F6 : Load BIOS Defaults	
		F7 : Load Setup Defaults	

Power Management

This field allows you to select the type of power saving management modes. There are four selections for Power Management.

- Disable No power management. (Default)
- Min. Power Saving Minimum power management.
- Max. Power Saving Maximum power management. Only available for SL CPU.
- User Define Each of the ranges are from 1 min. to 1hr. Except for HDD Power Down which ranges from 1 min. to 15 min.

Doze Mode

When enabled, and after the set time of system inactivity, the CPU clock will run at a slower speed while all other devices operate at full speed.

Suspend Mode

When enabled, and after the set time of system inactivity, all devices except the CPU will be shut off.

HDD Power Down

When enabled, and after the set time of system inactivity, the hard disk drive will be powered down while all other devices remain active.

RTC Alarm Function

This field enables or disables the RTC Alarm.

PM Events

The I/O events prevent the system from entering a power saving mode or can awaken the system from such a mode. When an I/O device wants to gain the attention of the operating system, it signals this by causing an IRQ to occur. When the operating system is ready to respond to the request, it interrupts itself and performs the service. The default value is *Off*. When set On, activity will neither prevent the system from going into a power management mode nor awaken it. The IRQ section sets the wake-up call of the system. If activity is detected from any enabled IRQ channels in the left-hand group, the system wakes up from suspended mode.

PNP/PCI Configuration

This option configures the PCI bus system. All PCI bus systems on the system use INT#, thus all installed PCI cards must be set to this value.

ROM PCI/ISA BIOS
PNP/PCI CONFIGURATION
AWARD SOFTWARE INC.

PNP OS Installed	: Yes	PCI IRQ Activated By	: Level
Resources Controlled by	: Auto	Used MEM base addr	: N/A
Reset Configuration Data	: Disabled		
		ESC : Quit ↑ ↓ ← : Select Item F1 : Help PU/PD/+/- : Modify F5 : Old Values (Shift) F2 : Color F6 : Load BIOS Defaults F7 : Load Setup Defaults	

PNP OS Installed

This field allows you to specify if the operating system installed in your system is plug and play aware.

NOTE: *Operating systems such as DOS, OS/2, and Windows 3.x do not use PnP.*

Resources Controlled by

This PnP BIOS can configure all of the boot and compatible devices automatically. However, this capability needs you to use a PnP operating system such as Windows 95 and Windows 98. The default value is **Auto**.

Reset Configuration Data

This field allows you to determine whether or not to reset the configuration data. The default value is **Disabled**.

IRQ3/4/5/7/9/10/11/12/14/15, DMA0/1/3/5/6/7 assigned to

These fields allow you to determine the IRQ/DMA assigned to the ISA bus and is not available to any PCI slot.

Used MEM base addr

This field allows the user to set the base address and block size of a legacy (non-PnP) ISA card that uses any memory segment within the C800H and DFFFH address range. If you have such a card and are not using an ICU (ISA Configuration Utility) to specify its address range, select a base address from the six available options. During selection, the “Used MEM Length” field will appear with the block size options. If you have more than one legacy ISA card in your system that require the use of this address range, you can increase the block size to either 8K, 16K, 32K or 64K. If you are using ICU to accomplish this task, leave “Used MEM base addr” to its default setting of N/A.

Load BIOS Defaults

This option allows you to load the troubleshooting default values permanently stored in the BIOS ROM. These default settings are non-optimal and disable all high-performance features.

ROM PCI/ISA BIOS
 CMOS SETUP UTILITY
 AWARD SOFTWARE, INC.

STANDARD CMOS SETUP	INTEGRATED PERIPHERALS
BIOS FEATURES SETUP	SUPERVISOR PASSWORD
CHIPSET FEATURES SETUP	USER PASSWORD
POWER MANAG	DETECTION
PNP/PCI CONFIG	IP
LOAD BIOS DEF	AVING
LOAD SETUP DEFAULTS	
ESC : Quit	↑ ↓ → ← : Select Item
F10 : Save & Exit Setup	(Shift) F2 : Change Color
Load BIOS Defaults except Standard CMOS Setup	

To load BIOS defaults value to CMOS SRAM, enter “Y”. If not, enter “N”.

Load Setup Defaults

This option allows you to load the default values to your system configuration. These default settings are optimal and enable all high performance features.

ROM PCI/ISA BIOS
 CMOS SETUP UTILITY
 AWARD SOFTWARE, INC.

STANDARD CMOS SETUP	INTEGRATED PERIPHERALS
BIOS FEATURES SETUP	SUPERVISOR PASSWORD
CHIPSET FEATURES SETUP	USER PASSWORD
POWER MANAGE	DETECTION
PNP/PCI CONFIG	TP
LOAD BIOS DEF	AVING
LOAD SETUP DEFAULTS	
ESC : Quit	↑ ↓ → ← : Select Item
F10 : Save & Exit Setup	(Shift) F2 : Change Color
Load BIOS Defaults except Standard CMOS Setup	

To load SETUP defaults value to CMOS SRAM, enter “Y”. If not, enter “N”.

Integrated Peripherals

This option allows you to determine the configuration of the integrated peripherals including hard disk drives USB, serial and parallel ports.

ROM PCI/ISA BIOS
INTEGRATED PERIPHERALS
AWARD SOFTWARE INC.

IDE HDD Block Mode	: Enabled	Onboard Serial Port 3	: 3F8H
Primary IDE Channel	: Enabled	Serial Port 3 Use IRQ	: IRQ10
Master Drive PIO Mode	: Auto	Onboard Serial Port 4	: 2E8H
Slave Drive PIO Mode	: Auto	Serial Port 4 Use IRQ	: IRQ9
Secondary IDE Channel	: Enabled		
Master Drive PIO Mode	: Auto		
Slave Drive PIO Mode	: Auto		
IDE Primary Master UDMA	: Auto		
IDE Primary Slave UDMA	: Auto		
IDE Secondary Master UDMA	: Auto		
IDE Secondary Slave UDMA	: Auto		
KBC input clock	: 8 MHz		
Onboard FDC Controller	: Enabled		
Onboard Serial Port 1	: 3F8/IRQ4	ESC : Quit	↑ ↓ ← : Select Item
Onboard Serial Port 2	: 2F8/IRQ3	F1 : Help	PU/PD/+/- : Modify
UR2 Mode	: Standard	F5 : Old Values	(Shift) F2 : Color
Onboard Parallel Port	: 378 / IRQ7	F6 : Load BIOS Defaults	
Parallel Port Mode	: ECP + EPP	F7 : Load Setup Defaults	

IDE HDD Block Mode

This field allows your hard disk controller to use the fast block mode to transfer data to and from your hard disk drive.

Primary / Secondary IDE Channel

These fields allow your system's hard disk controller to work faster. Rather than have the BIOS issue a series of commands that transfer to or from the disk drive, PIO (Programmed Input/Output) allows the BIOS to communicate with controller and CPU directly.

The system supports five modes, numbered from 0 (default) to 4, which primarily differ in timing. When Auto is selected, the BIOS will select the best available mode.

IDE Primary Master/Slave UDMA And Secondary Master/Slave UDMA

This field allows your system to improve disk I/O throughput with the Ultra DMA feature in the hard disk drive. The options are *Auto* and *Disabled*.

KBC Input Clock

The default setting for the keyboard controller input clock is **8 MHz**.

Onboard FDC Controller

This option allows you to select the onboard FDD port.

Onboard Serial/Parallel Port

These fields allow you to select the onboard serial/parallel port and its address. The default values for these ports are:

Serial Port 1	3F8/IRQ4
Serial Port 2	2F8/IRQ3
Serial Port 3	3E8/IRQ10
Serial Port 4	2E8/IRQ9
Parallel Port	378H/IRQ7

UR2 Mode

This field determines the UART 2 mode in your computer. The options are *Standard*, *HPSIR*, and *ASKIR*.

Onboard Parallel Mode

This field allows you to determine parallel port mode function.

Normal	Normal Printer Port
EPP	Enhanced Parallel Port
ECP	Extended Capabilities Port
ECP+EPP	Extended Capabilities Port or Enhanced Parallel Port

Build in CPU Audio

When enabled, other relevant Audio parameters are open for configuration. These include Audio I/O Base Address, MPU-401 I/O Base Address, Audio IRQ Select, Audio Low DMA Select, and Audio High DMA Select.

The MBC-4860 has two high drive digital outputs and two digital inputs (TTL level). You can configure the digital I/O to control the opening of the cash drawer and to sense the closing of the cash drawer. The following explains how the digital I/O is controlled via software programming.

Digital output programming is meant to drive relays or solenoid. Refer to the table below for digital output programming

Output	Address	Bit
Out 1	220	0
Out 2	220	1

Example: “0” is off “1” is on

```
Mov          AX, Data
Mov  DX, 0220H
Out  DX, AX
```

```
Data = 01
Out 0 = “1”
Out 1 = “0”
```

Digital Input Programming Table

Input	Address	Bit
IN-0	220	0
IN-1	220	1

```
Mov  DX, 0220H
IN   DX
```

```
If IN-0 = “1”
    IN-1 = “0”
Then AX = “1”
```

Note: The INPUT signal must be TTL compatible

Supervisor / User Password

These two options set the system password. *Supervisor Password* sets a password that will be used to protect the system and Setup utility. *User Password* sets a password that will be used exclusively on the system. To specify a password, highlight the type you want and press <Enter>. The **Enter Password:** message prompts on the screen. Type the password, up to eight characters in length, and press <Enter>. The system confirms your password by asking you to type it again. After setting a password, the screen automatically returns to the main screen.

To disable a password, just press the <Enter> key when you are prompted to enter the password. A message will confirm the password to be disabled. Once the password is disabled, the system will boot and you can enter Setup freely.

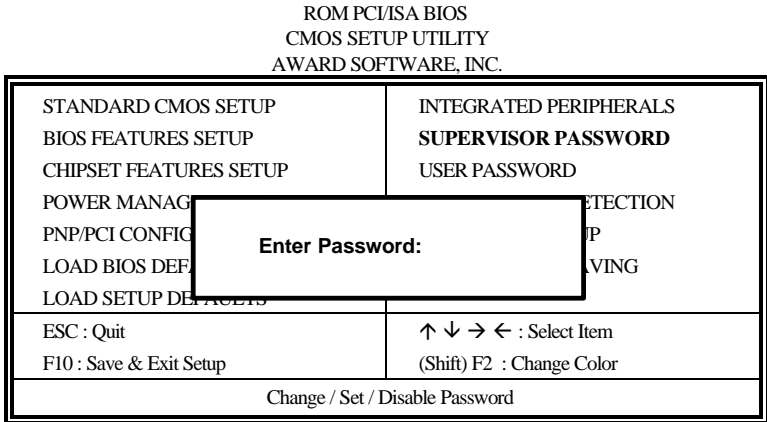

IDE HDD Auto Detection

This option detects the parameters of an IDE hard disk drive, and automatically enters them into Standard CMOS Setup screen.

ROM PCI/ISA BIOS
STANDARD CMOS SETUP
AWARD SOFTWARE, INC.

HARD DISKS	TYPE	SIZE	CYLS	HEAD	PRECOMP	LANDZ	SECTOR	MODE
Primary Master:								
Select Primary Master Option (N=SKIP) : N								
OPTIONS	TYPE	SIZE	CYLS	HEAD	PRECOMP	LANDZ	SECTOR	MODE
1 (Y)	0	0	0	0	0	0	0	NORMAL
ESC: SKIP								
NOTE: Some OSes (like SCO-UNIX) must use "NORMAL" for installation								

Up to four IDE drives can be detected, with parameters for each appearing in sequence inside a box. To accept the displayed entries, press the "Y" key to skip to the next drive, press the "N" key. If you accept the values, the parameters will appear listed beside the drive letter on the screen.

Save & Exit Setup

This option allows you to determine whether or not to accept the modifications. If you type “Y”, you will quit the setup utility and save all changes into the CMOS memory. If you type “N”, you will return to Setup utility.

ROM PCI/ISA BIOS
CMOS SETUP UTILITY
AWARD SOFTWARE, INC.

STANDARD CMOS SETUP	INTEGRATED PERIPHERALS
BIOS FEATURES SETUP	SUPERVISOR PASSWORD
CHIPSET FEATURES SETUP	USER PASSWORD
POWER MANAG	DETECTION
PNP/PCI CONFIG	UP
LOAD BIOS DEF	AVING
LOAD SETUP DEFAULTS	
ESC : Quit	↑ ↓ → ← : Select Item
F10 : Save & Exit Setup	(Shift) F2 : Change Color
Save Data to CMOS & Exit Setup	

Exit Without Saving

Select this option to exit the Setup utility without saving the changes you have made in this session. Typing “Y” will quit the Setup utility without saving the modifications. Typing “N” will return you to Setup utility.

ROM PCI/ISA BIOS
CMOS SETUP UTILITY
AWARD SOFTWARE, INC.

STANDARD CMOS SETUP	INTEGRATED PERIPHERALS
BIOS FEATURES SETUP	SUPERVISOR PASSWORD
CHIPSET FEATU	DETECTION
POWER MANAG	UP
PNP/PCI CONFIG	EXIT WITHOUT SAVING
LOAD BIOS DEF	
LOAD SETUP DEFAULTS	
ESC : Quit	↑ ↓ → ← : Select Item
F10 : Save & Exit Setup	(Shift) F2 : Change Color
Abandon all Data & Exit Setup	

6

Chapter6 VGA/Audio Driver Installation

This chapter provides information on how to install the graphics drivers, audio drivers, miniport drivers and ACPI bridge. Please follow the instructions set forth in this chapter carefully. It is recommended that you make a copy of the driver diskette and put the backup copy in a safe place.

The following items are covered in this chapter:

Installing Audio/VGA Drivers for Windows 9x.....	70
Installing VGA Drivers for Windows NT 4.0.....	72
Installing IDE Drivers for Windows NT 4.0	72

Installing VGA Drivers for Windows 9x

1. Insert the driver diskette in the floppy disk drive. Click Start, then Run. Assuming that a: is your floppy disk drive, type a:\win9x\national_geode_win9xdrivers_1.0.exe. When the file is executed, the welcome screen for the driver installation appears. Click Next to continue.
2. At this stage, the Software License Agreement is shown. Click Yes to accept the license agreement and continue the installation.
3. In the Choose Destination Location window, you are prompted to select the destination folder. Click Next to accept the default folder or click on Browse to change it. Refer to the figure below.



4. In the Setup Type window, choose Typical setup and click Next to continue.
5. In the Select Components window, the components selected by default are the Graphics Drivers, Minipower Drivers and Install ACPI Bridge. Click Next to accept the defaults and to start copying files. Refer to the figure below.



6. After file copying is done, click Finish to restart the computer and for changes to take effect.

Installing VGA Drivers for Windows NT 4.0

1. Once under the Windows NT 4.0 environment, click the Start button, then go to Settings and click on Control Panel.
2. Click on the Display icon to start the Display Properties window.
3. Click on the Settings tab, and then click Display Type.
4. Click Change. You are now prompted to type in the location of the driver. Assuming a: is your floppy disk drive, type in a:\winnt\vga (Don't forget to insert the driver diskette in the floppy disk drive.) Then, press <Enter>.
5. After the driver files are copied, restart the system for changes to take effect.

Installing IDE Drivers for Windows NT 4.0

1. Once under the Windows NT 4.0 environment, click the Start button, then go to Settings and click on Control Panel.
2. Click on the SCSI Adapters icon.
3. Now, click on Drivers → Add → Have Disk.
4. You are now prompted to type in the location of the driver. Assuming a: is your floppy disk drive, type in a:\winnt\ide (Don't forget to insert the driver diskette in the floppy disk drive.) Then, press <Enter>.
5. After the IDE driver files have been copied, restart the system for changes to take effect.

7

Chapter 7 LAN Driver Installation

This chapter describes LAN features and driver installation of the onboard Realtek RTL8139B Ethernet controller.

The following items are covered in this chapter:

Introduction.....	74
Features	74
Installing LAN Driver for Window 98/2000	75
Installing LAN Driver for Windows 95.....	76
Installing LAN Driver for Windows NT.....	77
Installing LAN Driver for DOS.....	78
Installing Driver for Windows for Workgroups	79

Introduction

Realtek RTL8139B is a 32-bit 10/100Mbps Ethernet controller for PCI local bus-compliant PCs. It supports the bus mastering architecture, and Auto-negotiation feature which make it possible to combine one common type of Ethernet cabling – an RJ-45 connector for twisted-pair cabling that can be used for both 10Mbps and 100Mbps connection. Extensive driver support for commonly used network operating systems is also provided.

Features

- Conforms to the Ethernet IEEE 802.3u standard
- Compatible with PCI Local Bus Revision 2.1 specification
- IEEE 802.3u Auto-Negotiation for automatic speed selection
- Supports Full-Duplex/Half-Duplex Operation
- Provides 32-bit bus mastering data transfer
- Supports 10Mbps and 100Mbps operation in a single port

The following section describes the installation driver procedure for Windows 98/Windows 2000, Windows 95, Windows NT, DOS, and Windows for Workgroup. To view the procedure of other operating systems, execute the *help8139.exe* in the diskette supplied.

Installing LAN Driver for Window 98/2000

This section describes the procedure to install Windows 98 and Windows 2000 driver for Realtek RTL8139B PCI Fast Ethernet adapter.

Before you start with the installation process, make sure that your adapter is properly installed in the PCI bus slot.

Executing Windows 98/ Windows 2000 will auto-detect your system configuration and find the adapter hardware. (If Windows 98 / Windows 2000 does not prompt that it detects the PCI Ethernet adapter, there must be something wrong with the Realtek RTL8139B PCI Fast Ethernet adapter or your system environment.)

1. When asked to select the driver you want to install, select "Driver from disk provided by hardware manufacturer".
2. Insert the Realtek RTL8139 driver disk into drive A and specify the setup file pathname A:\.
3. Windows 98/ Windows 2000 will appear with a message to insert Windows 98/ Windows 2000 system disk to complete setup.
4. Windows 98/ Windows2000 will finish other installation procedure automatically, and ask you to restart the system.

Installing LAN Driver for Windows 95

This section describes the procedure to install Windows 95 driver for Realtek RTL8139 PCI Fast Ethernet adapter.

Before you start with the installation process, make sure that your adapter is properly installed in the PCI bus slot. Executing Windows 95 will auto-detect your system configuration and find the adapter hardware. (If Win95 does not prompt that it detects the PCI Ethernet adapter, there must be something wrong with the RTL8139 PCI Fast Ethernet adapter or your system environment.)

1. When asked to select the driver you want to install, select "Driver from disk provided by hardware manufacturer".
2. Insert the Realtek RTL8139 driver disk into drive A and specify the setup file pathname A:\.
3. Windows 95 will appear with a message to insert Windows 95 system disk to complete setup.
5. Windows 95 will finish other installation procedure automatically, and ask you to restart the system.

Installing LAN Driver for Windows NT

This section describes the procedure to install Windows NT v3.5, v3.51 & v4.0 driver for Realtek RTL8139 PCI Fast Ethernet adapter.

When you are in Windows NT :

1. In the Main group of Windows NT, select the "Control Panel" icon.
2. In the Control Panel window, choose the "Network" icon.
3. In the Network Settings dialog box, choose the "Add Adapter" button.
The Add Network Adapter dialog box appears.
4. In the list of network cards, select "<other> Requires disk from manufacturer", and then press <Enter> button.
5. Insert the Realtek driver disk in drive A, enter drive and pathname A:\ which is the path where the setup file OEMSETUP.INF is located, and then choose the OK button.
6. The screen will appear "Select Line Speed" dialog box which is provided by RTL8139.SYS driver. The default value is "auto" so that the RTL8139 PCI Fast Ethernet adapter and its driver RTL8139.SYS will auto-detect the line speed, 10 Mb or 100Mb, while the RTL8139.SYS is loading. The other values, "10" or "100", are only used when you want to force RTL8139 PCI Fast Ethernet adapter to 10Mb or 100Mb.
7. The screen will appear "Input EthernetID" dialog box which is provided by RTL8139.SYS driver. This option is only required when you have more than one Realtek RTL8139 PCI Fast Ethernet adapters on the computer. Select "SKIP" if only one adapter installed on the computer.
8. "Bus Location" display in the next screen. Your machine contains more than one hardware bus, please select the Bus Type and Bus number on
9. NT will then perform the binding process. If any additional network software options were installed, you may be prompted for specific information for these packages.
10. Restarting your system you will require network service.

Installing LAN Driver for DOS

Before you start with the installation procedure, make sure that the adapter is properly installed and configured. Similarly, Make sure that your Microsoft Network Client is properly installed. (If not, The installation utility SETUP.EXE is located on Microsoft Network Client v3.0 for MS-DOS Disk. Run SETUP.EXE from Disk and the SETUP program screen will appear. Follow the instructions. The options are specific to your needs. The installation procedure will transfer files to a specific directory on the client and modify existing configuration files to fit your specific needs.)

1. Change to the Microsoft Network Client subdirectory, and run SETUP.EXE
2. The screen will display some information. Press <Enter>.
3. Respond to the screen prompts, selecting "Change Network Configuration", then press <Enter>.
4. Move the highlight to "Add Adapter", press <Enter>.
5. Select "Network adapter not shown on list below ...".
6. Insert the Realtek RTL8139 driver diskette in floppy A, and specify the pathname A:\NDIS2DOS, then press <Enter>.
7. Follow the screen instructions to complete the process. Simply pressing <Enter> for each screen display will select the default options. Press <Enter> until you reach the display prompting you to reboot the system.

Installing Driver for Windows for Workgroups

This section describes the procedure to install Microsoft Windows for Workgroups v3.11 driver for Realtek RTL8139B Fast Ethernet adapter.

1. When installing Windows for Workgroups, you are prompted for a network driver. Select the "Unlisted or Updated Network Driver".
2. Insert the REALTEK adapter driver disk containing OEMSETUP.INF and RTSND.DOS files.
3. Specify the directory for the driver (A:\WFW311) and select the Adapter driver.
4. Select Advanced options, and make sure the parameters match the card settings. Check keyword "EtherID", which is provided by RTSND.DOS. The installation program copies the necessary files and creates PROTOCOL.INI for use with the adapter.

Existing Windows for Workgroups Installation:

1. Select the "Network Setup" icon in the Network Group.
2. Select the "Driver.." button.
3. Select the "Add Adapters.." button.
4. Select "Unlisted or Updated Network Adapter"
5. Insert the adapter driver disk with OEMSETUP.INF and RTSND.DOS and specify the path A:\WFW311.
6. Select the REALTEK adapter driver.
7. The installation program copies the necessary files and creates PROTOCOL.INI for use with the adapter.
8. Select "Close" and when prompted, restart the computer for changes to take affect and complete the installation.

NOTE: You must have a terminated cable attached to the adapter when you start Windows for Workgroups. If you don't, Windows for Workgroups hangs.

Appendix

- A. I/O Port Address Map
- B. Interrupt Request Lines (IRQ)

A. I/O Port Address Map

Each peripheral device in the system is assigned a set of I/O port addresses which also becomes the identity of the device. There is a total of 1K port address space available. The following table lists the I/O port addresses used on the Embedded Little Board.

Address	Device Description
000h - 01Fh	DMA Controller #1
020h - 03Fh	Interrupt Controller #1
040h - 05Fh	Timer
060h - 06Fh	Keyboard Controller
070h - 07Fh	Real Time Clock, NMI
080h - 09Fh	DMA Page Register
0A0h - 0BFh	Interrupt Controller #2
0C0h - 0DFh	DMA Controller #2
0F0h	Clear Math Coprocessor Busy Signal
0F1h	Reset Math Coprocessor
1F0h - 1F7h	IDE Interface
278 - 27F	Parallel Port #2(LPT2)
2F8h - 2FFh	Serial Port #2(COM2)
2B0 - 2DF	Graphics adapter Controller
378h - 3FFh	Parallel Port #1(LPT1)
360 - 36F	Network Ports
3B0 - 3BF	Monochrome & Printer adapter
3C0 - 3CF	EGA adapter
3D0 - 3DF	CGA adapter
3F0h - 3F7h	Floppy Disk Controller
3F8h - 3FFh	Serial Port #1(COM1)

B. Interrupt Request Lines (IRQ)

There are a total of 15 IRQ lines available on the Embedded Little Board. Peripheral devices use interrupt request lines to notify CPU for the service required. The following table shows the IRQ used by the devices on the Embedded Little Board.

Level	Function
IRQ0	System Timer Output
IRQ1	Keyboard
IRQ2	Interrupt Cascade
IRQ3	Serial Port #2
IRQ4	Serial Port #1
IRQ5	Parallel Port #2
IRQ6	Floppy Disk Controller
IRQ7	Parallel Port #1
IRQ8	Real Time Clock
IRQ9	Software Redirected to Int 0Ah
IRQ10	Reserved
IRQ11	Reserved
IRQ12	Reserved
IRQ13	80287
IRQ14	Primary IDE
IRQ15	Secondary IDE