

WAFER-5820

Low Power GXLV-233 MMX with SVGA/LCD, Ethernet, & Audio SBC.

Copyright Notice

© Copyright 2000 by ICP Electronics Inc. All Rights Reserved. Manual first edition Apr..01, 2000.

The information in this document is subject to change without prior notice in order to improve reliability, design and function and does not represent a commitment on the part of the manufacturer.

In no event will the manufacturer be liable for direct, indirect, special, incidental, or consequential damages arising out of the use or inability to use the product or documentation, even if advised of the possibility of such damages.

This document contains proprietary information protected by copyright. All rights are reserved. No part of this manual may be reproduced by any mechanical, electronic, or other means in any form without prior written permission of the manufacturer.

Trademarks

WAFER-5820 is a registered trademark of ICP Electronics Inc. IBM PC is a registered trademark of International Business Machines Corporation. Intel is a registered trademark of Intel Corporation. Other product names mentioned herein are used for identification purposes only and may be trademarks and/or registered trademarks of their respective companies

Contents

1.Introduction.....	4
1.1 Specifications	
1.2 What You Have	
2.Installation.....	7
2.1 Wafer-5820 Block Diagram & Board Layout	
2.2 Unpacking Precautions	
2.3 System Memory DRAM	
2.4 Watch-Dog Timer Setting	
2.5 Clear CMOS Setup	
2.6 COM2 Setting JP12 , JP13	
2.7 LCD Vcc Voltage Selector	
2.8 DiskOnChip™ Flash Disk Memory Address setting	
3.Connection.....	12
3.1 Floppy Disk Drive Connector (CN7)	
3.2 PCI E-IDE Disk Drive Connector (CN2)	
3.3 Parallel Port (CN1)	
3.4 Series Ports (CN8, CN9)	
3.5 Audio Connector	
3.6 Keyboard & PS/2 Mouse Connector (CN6)	
3.7 USB Port Connector CN5	
3.8 IrDA Infrared Interface Port (CN11)	
3.9 VGA Connector (CN4)	
3.10 LCD/LVDS Interface Connector	
3.11 LAN RJ45 Connector	
3.12 Fan Connector (FAN1)	
3.13 External Power Connector	
3.14 PC/104 Connection Bus	
3.15 Ethernet LED and Power/HDD LEDES	

4.AWARD BIOS Setup	25
4.1 Getting Start	
4.2 Standard CMOS Setup	
4.3 BIOS Features Setup	
4.4 Chipset Features Setup	
4.5 Power Management Setup	
4.6 PNP / PCI CONFIGURATION	
4.7 LOAD BIOS DEFAULTS	
4.8 LOAD SETUP DEFAULTS	
4.9 INTEGRATED PERIPHERALS	
4.10 SUPERVISOR PASSWORD AND USER PASSWORD	
4.11 IDE HDD AUTODETECTION	
5.SVGA Setup	37
5.1 Introduction	
5.2 Further Information	
6.Audio	39
6.1 Introduction	
7.PCI Bus Ethernet Interface	40
7.1 Introduction	
Appendix A. Watch-Dog Timer	41
Appendix B. I/O Address Map	44

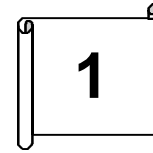

Introduction

WAFER-5820 is designed for limited space applications with only the size of a 3 ½" hard drive. It supports the full functions of an AT-compatible industrial computer on a single board. The WAFER-5820 is equipped with a low-power consumption and high performance GXLV-233 processor on board. It also contains an SDRAM SODIMM socket that can support up to 128MB memory.

The WAFER-5820 provides an Ethernet interface, audio interface, socket for DiskOnChip, EIDE interface, one parallel port, one serial ports RS-232, one series ports RS-232/422/485 with self-tuner, and a mini-DIN PS/2 keyboard/mouse interface. The built-in SVGA/LCD display controller supports both the CRT and LCD display simultaneously. It offers the resolutions of LCD screen up to 800 x 600 and CRT resolutions up to 1280 x 1024 @ 16 colors. It also provides LVDS interface for long distance LCD panel signal transmission. The display type is configured by software utility. The Flash ROM contains both the system BIOS and the VGA BIOS. The modification, in case of necessary, could be done by reprogramming the Flash ROM.

The RS485 has an outstanding characteristic of intelligent directing control which eliminates the extra control signal like RTS. With this feature you can develop your program as you are using a normal RS232 without special control routine. This is especially important in WINDOWS programming which do not allow the program to catch the control pin at your wish.

Finally, one PC/104 connector is included for the future application you will need.

1.1 Specifications

*NS GXLV-233 MMX 32-Bit x86 Processor

Supports Intel MMX instruction set extension for the acceleration of multi media applications

16 KB unified L1 cache

Five-stage pipelined integer unit

Integrated Floating Point Unit (FPU)

***System memory:** One 144-pin SODIMM socket support up to 128 MB SDRAM

***BIOS:** AWARD 256 KB Flash memory

*Display Controller

MediaGx processor has applied the UMA technology which provides 1-4MB display memory, to be set up by BIOS

Support CRT and TFT LCD displays simultaneously

Support 18-bit TFT LCD panel resolution up to 800x600 @ 18bpp

Support non-interlaced CRT monitors resolutions up to 1280x1024 @ 256 colors or 1024x768 @ 16bpp

*Audio

Compliant to AC97, support stereo

Connector: Speaker, Mic-in, Line-in, Line-out, CD-ROM in

***IDE interface:** The IDE support to two PCI Enhanced IDE hard drives

***FDD interface:** support up to two floppy disk drives, 5.25" ; 360KB and 1.2MB; and/or 3.5" ; 720KB, 1.44MB, and 2.88MB; ^

***Series ports:** two RS232 ports, one RS232 port can be set to RS-422/485 with Self-Tuner technology or can be set to infrared port with Transfer rate up to 115 KBPS

***Parallel port:** One Parallel port, supports SPP/EPP/ECP mode

***PS/2 Mouse/Keyboard connector:** A6-pin mini DIN connector is located on the mounting bracket for easy connection to a keyboard or PS/2 mouse

***USB interface:** two USB ports, USB 1.0 compliant

***Power management:** supports power saving modes including Normal/Doze/Sleep modes. APM1.1 compliant

***Watch-dog timer:** can be set by 1-255 seconds period. Reset or NMI was generated when CPU did not periodically trigger the timer.

***10/100Mbps Ethernet Controller:** Realtek RTL8139 IEEE802.u 100 BASE-TX standard Dual Auto-sensing interface to 10Mbps or 100Mbps networks. On board RJ45 connectors provide for easy connection.

***DiskOnChip™ Flash Disk:** supports one 32-pin socket for DiskOnChip Flash Disk

***Power supply:** 2A@+5V, 100mA@+12V (GXLV 233MHz CPU and 32MB SDRAM)

***Operating temperature:** -20-60°C (-4-140°F)

***Dimension:** 5.9" (L) x 4.2" (W) (145mmx102mm)

1.2 What You Have

Before you begin installing the product, please check the following materials are included in the package:

- 1 Wafer -5820 All-in-one single board computer
- 1 CD disk for utility and drivers
- 1 2.5" IDE flat cable (44-pin 2.0mm pitch to 44-pin 2.54mm pitch)
- 1 one to two 6pin mini Din connector for keyboard and mouse
- 1 combo serial port cable (RS -232/422/485)
- 1 standard D25 connector for parallel cable
- 1 dual USB connector cable
- 1 floppy cable (for 3.5" FDD only)
- 1 audio cable sets

If any of these items are missing or damaged, contact your distributor or sales representative immediately.

2

Installation

This chapter gives instructions about how to set up the WAFER-5820 hardware, including directions of setting jumpers and connecting peripherals, switches and indicators. Before installation, please pay attention to the unpacking precautions on the following page for safety.

2.1 Wafer-5820 Block Diagram & Board Layout

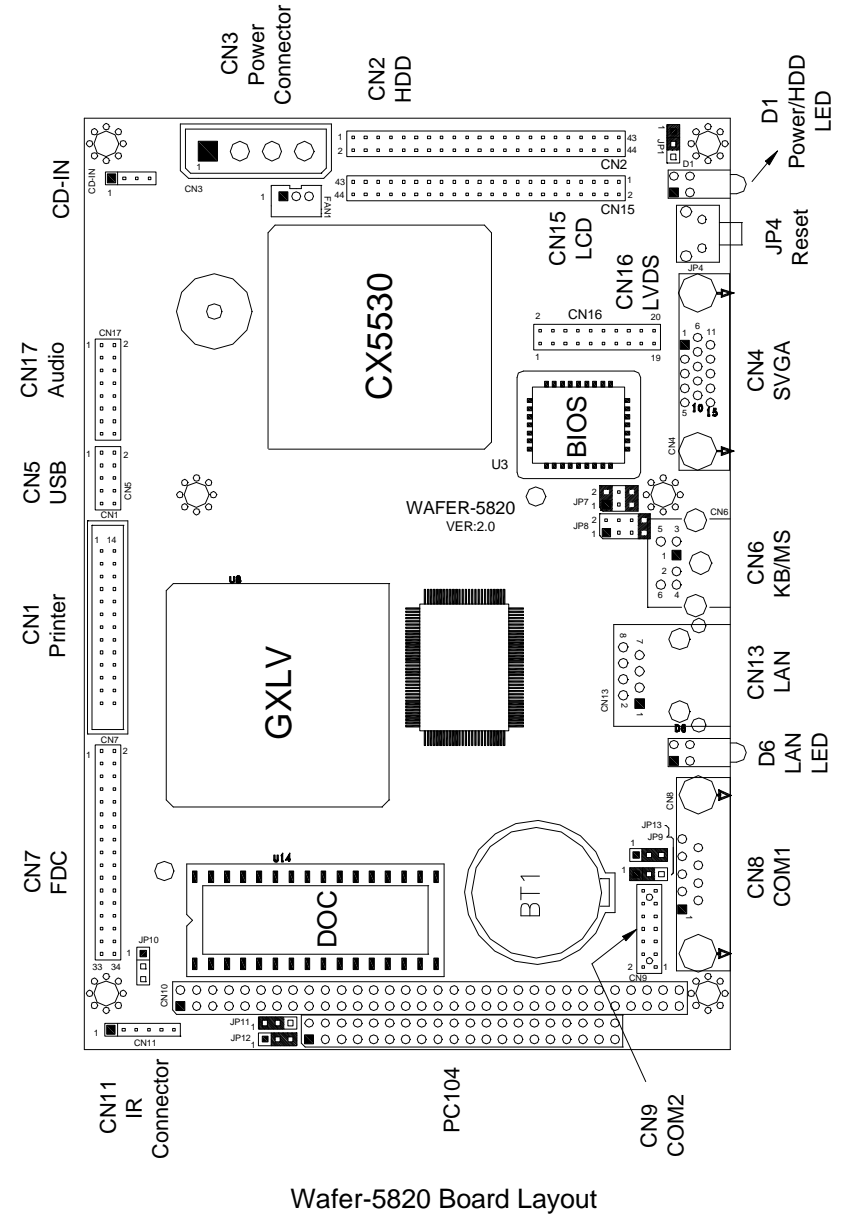
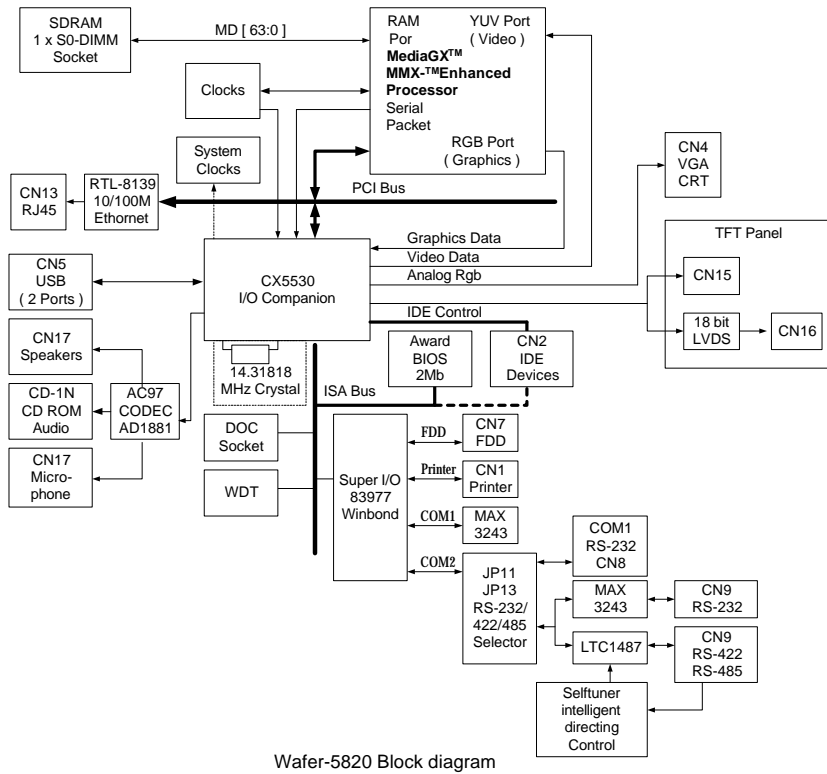

2.2 Unpacking Precautions

Some components of WAFER-5820 SBC are very sensitive to static electric charges and can be damaged by a sudden rush of power. To protect it from unintended damage, be sure to note these precautions:

Ground yourself to remove any static charge before touching the Wafer-5820 SBC. You can do it by using a grounded wrist strap at all times or by frequently touching any conducting materials that is connected to the ground.

Handle your Wafer-5820 SBC by its edges. Don't touch IC chips, leads or circuitry if not necessary.

Do not plug any connector or jumper while the power is on.

2.3 System Memory DRAM

There is one 144-pin SO-DIMM socket to accept 3.3V non-buffered SDRAM. The max. Memory size is 128MB.

2.4 Watch-Dog Timer Setting

The Watch-Dog Timer is enabled by reading port 443H. It should be triggered before the time-out period ends, otherwise it will assume the program operation is abnormal and will issue a reset signal to start again, or activate NMI to CPU. The Watch-Dog Timer is disabled by reading port 043/843H. detail information on Watch-Dog Timer Refer to Appendix A

- JP10 : Watch-Dog Active Type Setting

JP10	DESCRIPTION
1-2	ACTIVATE NMI TO CPU WHEN WDT TIME-OUT
2-3	RESET WHEN WDT TIME-OUT
OPEN	DISABLE WDT

2.5 Clear CMOS Setup

If you need to clear the CMOS Setup (for example forgot the password you should clear the setup and then set the password again.), you should close the JP9 about 3 seconds, then open it again. Set back to normal operation mode, open JP9.

- JP9: Clear CMOS Setup (Reserve Function)

JP9	DESCRIPTION
1-2	Normal Operation
2-3	Clear CMOS Setup

2.6 COM2 Setting JP12 , JP13

The COM2 (CN9) can supply +5V or +12V power to the serial devices via RI pin (Pin 8) of the COM port connector. The max. current is 1A with fuse protection, from these two connector's 5V/12V output. If the output is set to 12V, make sure that you have 12V to supply to the board.

CN9 Pin 8	JP13	JP12
RI Signal	2-3	Don't care
+5V	1-2	2-3
+12V	1-2	1-2

COM2 RS-232, RS-422 or RS-485 Setting JP11

The COM2 (CN9) can be set to RS-232 or RS-422/485 for industrial field site application. Moreover when this port set to the RS-485 mode the board equipped self-tuner IC will automatic sensing the data direction to eliminate the data collision. This is especially important in WINDOWS programming which do not allow the program to catch the control pin at your wish.

JP11	DESCRIPTION
1-2	RS232
2-3	RS422/RS485

2.7 LCD Vcc Voltage Selector

The LCD interface connector CN15 can provide 5V or 3.3V power supply by selecting the JP1 to meet the different LCD requirement.

JP1	DESCRIPTION
1-2	5V
2-3	3.3V

2.8 DiskOnChip™ Flash Disk Memory Address setting

The DiskOnChip™ Flash Disk Chip (DOC) is produced by M-Systems. Because the DOC is 100% compatible to hard disk and DOS Customer don't need any extra software utility. It is just "plug and play", easy and reliable. Right now the DOC is available from 2MB to 144MB. **The MD-2200-Xmb series DOC will share only 8KB memory address.**

- JP7 & JP8: DiskOnChip Memory Address Setting

ADDRES	JP8				JP7		
	1-2	3-4	5-6	7-8	1-2	3-4	5-6
CC000	OPEN	OPEN	CLOSE	OPEN	OPEN	CLOSE	CLOSE
CE000	OPEN	OPEN	OPEN	CLOSE	OPEN	CLOSE	CLOSE
D0000	CLOSE	OPEN	OPEN	OPEN	CLOSE	OPEN	CLOSE
D2000	OPEN	CLOSE	OPEN	OPEN	CLOSE	OPEN	CLOSE
D4000	OPEN	OPEN	CLOSE	OPEN	CLOSE	OPEN	CLOSE
D6000	OPEN	OPEN	OPEN	CLOSE	CLOSE	OPEN	CLOSE
D8000	CLOSE	OPEN	OPEN	OPEN	OPEN	OPEN	CLOSE
DA000	OPEN	CLOSE	OPEN	OPEN	OPEN	OPEN	CLOSE
DC000	OPEN	OPEN	CLOSE	OPEN	OPEN	OPEN	CLOSE
DE000	OPEN	OPEN	OPEN	CLOSE	OPEN	OPEN	CLOSE

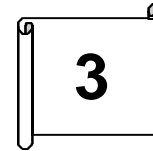

3 Connection

This chapter describes how to connect peripherals, switches and indicators to the WAFER-5820 board.

3.1 Floppy Disk Drive Connector (CN7)

WAFER-5820 board is equipped with a 34-pin daisy-chain driver connector cable.

CN7: FDC CONNECTOR

PIN NO.	DESCRIPTION	PIN NO.	DESCRIPTION
1	GROUND	2	REDUCE WRITE
3	GROUND	4	N/C
5	GROUND	6	N/C
7	GROUND	8	INDEX#
9	GROUND	10	MOTOR ENABLE A#
11	GROUND	12	DRIVE SELECT B#
13	GROUND	14	DRIVE SELECT A#
15	GROUND	16	MOTOR ENABLE B#
17	GROUND	18	DIRECTION#
19	GROUND	20	STEP#
21	GROUND	22	WRITE DATA#
23	GROUND	24	WRITE GATE#
25	GROUND	26	TRACK 0#
27	GROUND	28	WRITE PROTECT#
29	GROUND	30	READ DATA#
31	GROUND	32	SIDE 1 SELECT#
33	GROUND	34	DISK CHANGE#

3.2 PCI E-IDE Disk Drive Connector (CN2)

For IDE HDD connection, The Wafer-5820 was designed with one 2.0mm connector (CN2), which could be converted to two 2.54mm standard IDE connector via proprietary cable. Using this cable you can attach two IDE hard disk drives to the WAFER-5820.

CN2 : 44-pin Primary Mini-pitched IDE Interface Connector

- CN2 : Primary IDE Interface Connector

PIN NO.	DESCRIPTION	PIN NO.	DESCRIPTION
1	RESET#	2	GROUND
3	DATA 7	4	DATA 8
5	DATA 6	6	DATA 9
7	DATA 5	8	DATA 10
9	DATA 4	10	DATA 11
11	DATA 3	12	DATA 12
13	DATA 2	14	DATA 13
15	DATA 1	16	DATA 14
17	DATA 0	18	DATA 15
19	GROUND	20	N/C
21	IDE DRQ	22	GROUND
23	IOW#	24	GROUND
25	IOR#	26	GROUND
27	IDE CHRDY	28	GROUND
29	IDE DACK	30	GROUND-DEFAULT
31	INTERRUPT	32	N/C
33	SA1	34	N/C
35	SA0	36	SA2
37	HDC CS0#	38	HDC CS1#
39	HDD ACTIVE#	40	GROUND
41	VCC	42	GROUND
43	GROUND	44	GROUND

3.3 Parallel Port (CN1)

This port is usually connected to a printer, The WAFER-5820 includes an on-board parallel port(CN1), accessed through a 26-pin flat-cable connector .

- CN1: Parallel Port Connector

PIN NO.	DESCRIPTION	PIN NO.	DESCRIPTION
1	STROBE#	2	DATA 0
3	DATA 1	4	DATA 2
5	DATA 3	6	DATA 4
7	DATA 5	8	DATA 6
9	DATA 7	10	ACKNOWLEDGE
11	BUSY	12	PAPER EMPTY
13	PRINTER SELECT	14	AUTO FORM FEED #
15	ERROR#	16	INITIALIZE
17	PRINTER SELECT LN#	18	GROUND
19	GROUND	20	GROUND
21	GROUND	22	GROUND
23	GROUND	24	GROUND
25	GROUND	26	N/C

3.4 Series Ports (CN8, CN9)

The Wafer-5820 offers two high speeds NS16C550 compatible UARTs with Read/Receive 16 byte FIFO serial ports. These ports let you connect to serial devices or a communication network. One 9-pin D-SUB connector and one 14-pin header are provided by the WAFER-5820. The detailed pin assignment of the connectors are specified as following tables:

- CN8: Serial Port1 Connector (9-pin DSUB)

PIN NO.	DESCRIPTION
1	DATA CARRIER DETECT (DCD)
2	RECEIVE DATA (RXD)
3	TRANSMIT DATA (TXD)
4	DATA TERMINAL READY (DTR)
5	GROUND (GND)
6	DATA SET READY (DSR)
7	REQUEST TO SEND (RTS)
8	CLEAR TO SEND (CTS)
9	RING INDICATOR (RI)

- CN9: Serial Port2 Connector (14-pin Header/W Housing)

PIN NO.	DESCRIPTION	PIN NO.	DESCRIPTION
1	DCD	2	DSR
3	RX	4	RTS
5	TX	6	CTS
7	DTR	8	RI
9	GND	10	N/C
11	TX2+	12	TX2-
13	RX2+	14	RX2-

} RS-232
} RS-422/485

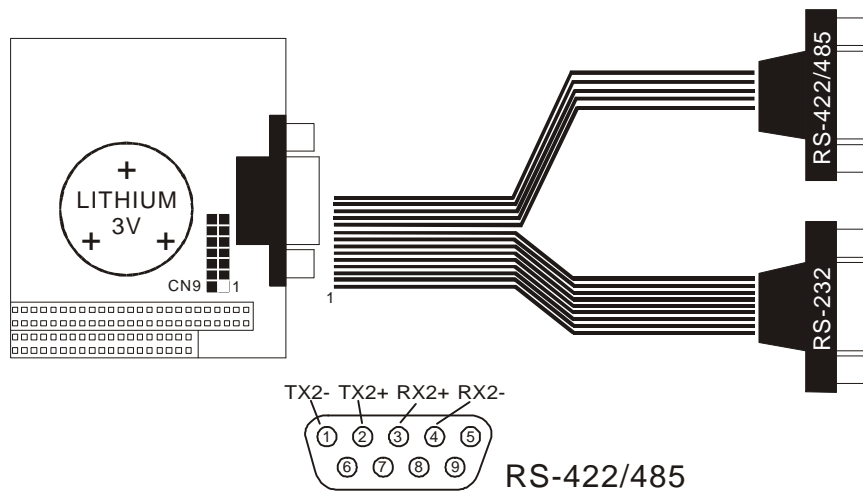

Note : TX2+,TX2- and RX2+,RX2- are for transmitting and receiving, respectively, in the RS-422 connection. While in RS-485 connection, TX2+,RX2+ and TX2-,RX2- must be twisted each. Anyhow, you can only choose to use **RS-232** or **RS-422/485**.

3.5 Audio Connector

The audio function was organized by CX5530 I/O companions and NS AD1881 CODEC, which compliant with AC97. You can use CD-IN as the input port (e.g.: connected to the output of CD player), depending on the type of connector that you have.

- CD-IN : CD_AUDIO INPUT Connector

PIN NO.	DESCRIPTION
1	JCD_R
2	GND
3	JCD_L
4	GND

- CN17: Audio Connector

This is the output port of your Sound System. Pin 1-2-3 can be connected to earphone and 5-6-7 can be connected to loudspeaker. Pin 9-10-11 can be used as input port if it is connected to the earphone jack of your CD. Pin 15-16 is for microphone.

PIN NO.	DESCRIPTION	PIN NO.	DESCRIPTION
1	LINE OUT L	2	GND
3	LINE OUT R	4	GND
5	LINE OUT R	6	LINE OUT L
7	GND	8	GND
9	LINE IN R	10	LINE IN L
11	GND	12	GND
13	N/C	14	N/C
15	MIC IN	16	GND

3.6 Keyboard & PS/2 Mouse Connector (CN6)

A 6-pin mini DIN connector (CN6) is located on the mounting bracket for easy connection to a keyboard or PS/2 mouse. The card comes with a cable to convert from the 6-pin mini-DIN connector to two 6-pin mini-DIN connector for keyboard and mouse connection

- CN6: 6-pin Mini-DIN Keyboard & Mouse Connector

PIN NO.	DESCRIPTION
1	KEYBOARD DATA
2	MOUSE DATA
3	GROUND
4	+5V
5	KEYBOARD CLOCK
6	MOUSE CLOCK

3.7 USB Port Connector CN5

The WAFER-5820 provides two USB interfaces, which gives the completed plug and play, for up to 127 external devices.

- CN5: Internal USB Connector

1.	USBVCC1	2.	D1F-
3.	D1F+	4.	GND
5.	USBVCC2	6.	D2F-
7.	D2F+	8.	GND
9.	GND	10.	GND

3.8 IrDA Infrared Interface Port (CN11)

The WAFER-5820 built-in a IrDA port which support Serial Infrared (SIR) or Amplitude Shift Keyed IR(ASKIR) interface. When use the IrDA port have to set SIR or ASKIR model in the BIOS's Peripheral Setup's COM2. Then the normal RS -232 COM2 will be disabled.

- CN11: IrDA connector

PIN NO.	DESCRIPTION
1	VCC
2	FIRRX
3	IRRX
4	Ground
5	IR-TX
6	CIR

3.9 VGA Connector (CN4)

The WAFER-5820 built-in 15-pin VGA connector accepts the CRT monitor.

- CN4: 15-pin Female Connector

1	RED	2	GREEN
3	BLUE	4	NC
5	GROUND	6	GROUND
7	GROUND	8	GROUND
9	NC	10	GROUND
11	NC	12	DDC DAT
13	HSYNC	14	VSYNC
15	DDCCLK		

3.10 LCD/LVDS Interface Connector

The WAFER-5820 provides a 2x22-pin connector for the LCD flat panel interface and a 2x10-pin connector for the LVDS flat panel interface.

The Wafer 5820 comes to support TFT LCD panels at following display options : (This is a reference table only , may support more type panels)

Video Display type	Resolution	Example
TFT VGA	640X480 , 64K Color , 18bits	Toshiba LTM10C209A
TFT SVGA	800X600 , 64K Color , 18bits	Toshiba LTM12C275A

The TTL signal connecting interfaces located on CN15 while LVDS on CN16.

The display options need to be setup manually from BIOS. The BIOS “**Integrated Peripheral**” Setup will allow you to choose display resolution either 640X480 or 800X600.

- CN15: LCD Interface Connector – only support up to 24 bit LCD. For better display quality, the length of LCD cable should be shorter than 35 cm.

PIN NO.	Description	PIN NO.	Description
1	+12V	2	+12V
3	GND	4	GND
5	+5V	6	+5V
7	FPVVEE	8	GND
9	P0	10	P1
11	P2	12	P3
13	P4	14	P5
15	P6	16	P7
17	P8	18	P9
19	P10	20	P11
21	P12	22	P13
23	P14	24	P15
25	P16	26	P17
27	P18	28	P19
29	P20	30	P21
31	P22	32	P23
33	GND	34	GND
35	SHFCLK	36	FLM
37	M	38	LP
39	GND	40	ENABLK
41	GND	42	N/C
43	+5V	44	5V

• CN16: LVDS Interface Connector

PIN NO.	Description	PIN NO.	Description
1	PCLD(5V/12V)	2	PCLD(5V/12V)
3	GND	4	GND
5	TxOUT0A-	6	TxOUT0A+
7	GND	8	TxOUT1A-
9	TxOUT1A+	10	GND
11	TxOUT2A-	12	TxOUT2A+
13	GND	14	TxCLKOUTA-
15	TxCLKOUTA+	16	GND
17	FPENABKL	18	FPENAVDD
19	GND	20	GND

• EVDS Signal Description—only support up to 18-bit LCD.

P18 (R0)	TxOUT0A- TxOUT0A+	P4 (B2)	TxOUT2A- TxOUT2A+
P19 (R1)		P5 (B3)	
P20 (R2)		P6 (B4)	
P21 (R3)		P7 (B5)	
P22 (R4)		LP	
P23 (R5)		FLM	
P10 (G0)		M	
P11 (G1)	TxOUT1A- TxOUT1A+	SHFCLK	TxCLKOUTA- TxCLKOUTA-
P12 (G2)			
P13 (G3)			
P14 (G4)			
P15 (G5)			
P2 (B0)			
P3 (B1)			

3.11 LAN RJ45 Connector

The WAFER-5820 built-in RJ45 LAN connector is for 10/100Mbps Ethernet (RTL8139B).

- CN13: LAN RJ45 Connector

1	TX+	5	NC
2	TX-	6	RX-
3	RX+	7	NC
4	NC	8	NC

3.12 Fan Connector (FAN1)

The WAFER-5820 provides CPU cooling fan connector FAN1 that can supply 12V & 5V. to the cooling fan.

- FAN1: Fan Connector

PIN NO.	DESCRIPTION
1	VCC5V
2.	Ground
3.	12V

3.13 External Power Connector

The WAFER-5820 has an on-board external power connector CN3. You can connect power directly to the CPU board.

- CN3: External Power Connector

PIN NO.	DESCRIPTION
1	+12V
2	GROUND
3	GROUND
4	VCC5V

3.14 PC/104 Connection Bus

The WAFER-5820 PC/104 expansion bus let you attach any kind of PC/104 modules. The PC/104 bus has already become the industrial embedded PC bus standard, so you can easily install over thousands of PC/104 modules from hundreds of vendors in the world. There are two PC/104 connectors on this board: PC/104-64 and PC/104-40.

- CN12: PC/104-40 Connector

PIN NO.	Description	PIN NO	Description
1	GND	21	GND
2	SBHE#	22	MCS16#
3	LA23	23	IOCS16#
4	LA22	24	IRQ10
5	LA21	25	IRQ11
6	LA20	26	IRQ12
7	LA19	27	IRQ15
8	LA18	28	IRQ14
9	AL17	29	DACK0#
10	MEMR#	30	DRQ0
11	MEMW#	31	DACK5#
12	SD8	32	DRQ5
13	SD9	33	DACK6#
14	SD10	34	DRQ6
15	SD11	35	DACK7#
16	SD12	36	DRQ7
17	SD13	37	VCC
18	SD14	38	MASTER#
19	SD15	39	GND
20	GND	40	GND

- CN10: PC/104-64 Connector

PIN NO.	Description	PIN NO.	Description
1	IOCHCK#	33	GND
2	SD7	34	IRSTDRV
3	SD6	35	VCC
4	SD5	36	IRQ9
5	SD4	37	-5V
6	SD3	38	N/C
7	SD2	39	-12V
8	SD1	40	ZWS
9	SD0	41	+12V
10	IOCHRDY	42	GND
11	AEN	43	SMEMW#
12	LA19	44	SMEMR#
13	LA18	45	IOW#
14	LA17	46	IOR#
15	SA16	47	DACK3#
16	SA15	48	DRQ3
17	SA14	49	DACK1#
18	SA13	50	DRQ1
19	SA12	51	REFRESH#
20	SA11	52	SYSCLK
21	SA10	53	IRQ7
22	SA9	54	N/C
23	SA8	55	IRQ5
24	SA7	56	IRQ4
25	SA6	57	IRQ3
26	SA5	58	N/C
27	SA4	59	TC
28	SA3	60	BALE
29	SA2	61	VCC
30	SA1	62	OSC
31	SA0	63	GND
32	GND	64	GND

3.15 Ethernet LED and Power/HDD LEDS

D6: Ethernet LED setup

LED	Setting
Green lamp	Rx
Orange lamp	Tx

D1: Power/HDD setup

LED	Setting
Green lamp	Power
Orange lamp	HDD

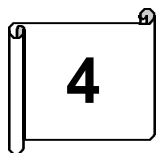

AWARD BIOS Setup

WAFER-5820 uses the AWARD PCI/ISA BIOS for system configuration. The AWARD BIOS setup program is designed to provide maximum flexibility in configuring the system by offering various options which may be selected to meet end-user requirements. This chapter is written to assist you in the proper usage of these features.

4.1 Getting Start

When you turn on the power button, the BIOS will enter the Power-On-Self-Test routines. These routines will be executed for system test and initialization and system configuration verification. After the POST routines are completed, the following message appears :

" Hit DEL if you want to run SETUP"

To access AWARD BIOS SETUP UTILITY, press key. The following screen will be displayed at this time:

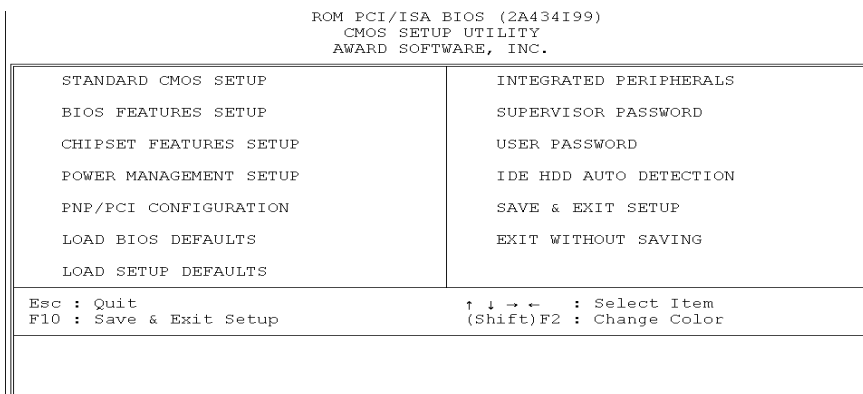

4.2 Standard CMOS Setup

The Standard CMOS Setup is used for basic hardware system configuration. The main function is for Date/Time setting and Floppy/Hard Disk Drive setting. Please refer the following screen for this setup.

ROM PCI/ISA BIOS (2A434I99)
STANDARD CMOS SETUP
AWARD SOFTWARE, INC.

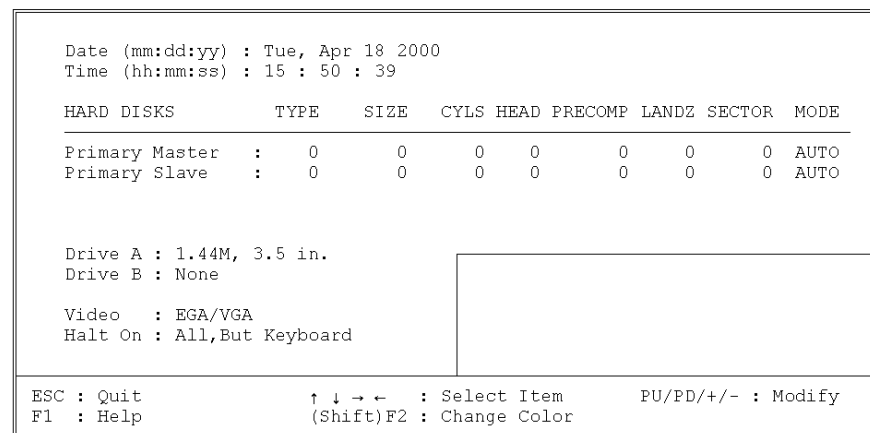

To set the Date, for example, press either the arrow or <Enter> button on your keyboard to select one of the fields (Month, Date or Year) then press either <PgUp> or <PgDn> to increase or decrease the value of that field. Do the same steps for Time setting.

For IDE hard disk drive setup, please check the following possible setup procedure:

1. Use the Auto setting for detection during boot-up.
2. Use the IDE HDD AUTO DETECTION in the main menu, the computer will automatically detect the HDD specifications.

4.5 Power Management Setup

Power Management Setup helps user to handle the ROCKY-568SEV boards "green" function. This feature can shut down the video display and hard disk to save energy, for example. The power management setup screen is as following

```

ROM PCI/ISA BIOS (2A434I99)
POWER MANAGEMENT SETUP
AWARD SOFTWARE, INC.

```

Power Management	: Disabled	IRQ1 (KeyBoard)	: ON
		IRQ3 (COM 2)	: OFF
** PM Timers **		IRQ4 (COM 1)	: OFF
Doze Mode	: Disabled	IRQ5 (LPT 2)	: OFF
Standby Mode	: Disabled	IRQ6 (Floppy Disk)	: OFF
HDD Power Down	: Disabled	IRQ7 (LPT 1)	: OFF
MODEM Use IRQ	: NA	IRQ9 (IRQ2 Redir)	: OFF
		IRQ10 (Reserved)	: OFF
Throttle Duty Cycle	: 33.3 %	IRQ11 (Reserved)	: OFF
		IRQ12 (PS/2 Mouse)	: OFF
		IRQ13 (Coprocessor)	: OFF
		IRQ14 (Hard Disk)	: OFF
		IRQ15 (Reserved)	: OFF

```

ESC : Quit      ↑↓←→ : Select Item
F1  : Help      PU/PD/+/- : Modify
F5  : Old Values (Shift)F2 : Color
F6  : Load BIOS Defaults
F7  : Load Setup Defaults

```

4.6 PNP / PCI CONFIGURATION

This menu is used to assign certain IRQ to your PNP/PCI devices manually.

```

ROM PCI/ISA BIOS (2A434I99)
PNP/PCI CONFIGURATION
AWARD SOFTWARE, INC.

```

PNP OS Installed	: No	PCI IRQ Activated By	: Level
Resources Controlled By	: Auto		
Reset Configuration Data	: Disabled		

```

ESC : Quit      ↑↓←→ : Select Item
F1  : Help      PU/PD/+/- : Modify
F5  : Old Values (Shift)F2 : Color
F6  : Load BIOS Defaults
F7  : Load Setup Defaults

```

PNP OS Installed: if you install Plug and Play operating system (OS), the OS will reassign the interrupt if you select *Yes* in this field. If you install a non-Plug and Play OS or if you want to prevent reassigning of interrupt settings, select *No* in this field.

Resources Controlled By: select *Auto* if you want the computer to assign the IRQs automatically and vice versa.

Reset Configuration Data: *Enabling* this field means you allow the configuration data to be reset.

IRQ-xx assigned to: these fields show whether certain IRQ is used by a PCI/ISA card.

4.7 LOAD BIOS DEFAULTS

```

ROM PCI/ISA BIOS (2A434I99)
CMOS SETUP UTILITY
AWARD SOFTWARE, INC.

```

STANDARD CMOS SETUP	INTEGRATED PERIPHERALS
BIOS FEATURES SETUP	SUPERVISOR PASSWORD
CHIPSET FEATURES SETUP	USER PASSWORD
POWER MANAGEMENT SETUP	IDE HDD AUTO DETECTION
PNP/PCI CONFIGURA	ETUP
LOAD BIOS DEFAULT	LOAD SETUP Defaults (Y/N)? Y
LOAD SETUP DEFAULTS	SAVING

```

Esc : Quit          ↑ ↓ → ← : Select Item
F10 : Save & Exit Setup  (Shift)F2 : Change Color

```

If you select 'Y' to this field, the BIOS Defaults will be loaded except Standard CMOS SETUP. The default settings are not optimal and turning all high performance into disable condition. Select 'N' to abort.

Suggestion: for the first time or for our primary user, we suggest you to use LOAD SETUP DEFAULTS because it is the most safe mode for your system.

4.8 LOAD SETUP DEFAULTS

```

ROM PCI/ISA BIOS (2A434I99)
CMOS SETUP UTILITY
AWARD SOFTWARE, INC.

```

STANDARD CMOS SETUP	INTEGRATED PERIPHERALS
BIOS FEATURES SETUP	SUPERVISOR PASSWORD
CHIPSET FEATURES SETUP	USER PASSWORD
POWER MANAGEMENT SETUP	IDE HDD AUTO DETECTION
PNP/PCI CONFIGURA	ETUP
LOAD BIOS DEFAULT	Load SETUP Defaults (Y/N)? N
LOAD SETUP DEFAULTS	SAVING

```

Esc : Quit          ↑ ↓ → ← : Select Item
F10 : Save & Exit Setup  (Shift)F2 : Change Color

```

If you select 'Y' to this field, the Setup Defaults will be loaded except Standard CMOS SETUP. The default settings are optimal configuration settings for your system.

4.9 INTEGRATED PERIPHERALS

```

ROM PCI/ISA BIOS (2A434I99)
INTEGRATED PERIPHERALS
AWARD SOFTWARE, INC.

```

Primary IDE Channel : Enabled	Build in CPU Audio : Enabled
Master Drive PIO Mode : Auto	Audio I/O Base Address : 220H
Slave Drive PIO Mode : Auto	MPU-401 I/O Base Address : 330H
IDE Primary Master UDMA : Auto	Audio IRQ Select : IRQ 5
IDE Primary Slave UDMA : Auto	Audio Low DMA Select : DMA 1
	Audio High DMA Select : DMA 5
Onboard FDC Controller : Enabled	
Onboard Serial Port 1 : 3F8/IRQ4	Multiple Monitor Support : No Onboard
Onboard Serial Port 2 :	
UART Mode Select :	Video Memory Size : 2.5 M
UART2 Duplex Mode : Half	Flat Panel Status : Enabled
RxD , TxD Active : Hi,Lo	Flat Panel Resolution : 640x480
IR Transmission delay : Enabled	
Onboard Parallel Port :	
ECP Mode Use DMA : 3	
EPP Mode Select : EPP1.7	ESC : Quit ↑↓←→ : Select Item
	F1 : Help PU/PD/+/- : Modify
	F5 : Old Values (Shift)F2 : Color
	F6 : Load BIOS Defaults
	F7 : Load Setup Defaults

This option is used to assign Onboard I/O, IRQ, DMA etc. If you don't know how to configure them, just press <F7> to load Setup Defaults.

The flat panels will then be applied with two modes: 640x480 or 800x600, for which it need to set up from BIOS for proper flat panel resolution.

- **Build in CPU Audio -- Enabled, Disabled**
To disable or enable the audio function.
- **Audio I/O Base Address -- 220H, 240H, 260H, 280H**
To select the I/O address for audio function.
- **MPU-401 I/O Base Address -- 300H, 330H, Disabled**
To select the I/O address for MPU-401 (midi interface).
- **Audio IRQ Select -- 5, 7, 10, Disabled**
To select the interrupt for audio function.
- **Audio Low DMA Select -- DMA0, DMA1, DMA3, Disabled**
To select the high DMA channel.

- **Audio High DMA Select -- DMA5, DMA6, DMA7, Disabled**
To select the high DMA channel.
- **Multiple Monitor Support -- No Onboard, PCI first, M/B first**
To select the primary VGA for multiple monitor support in WINDOWS.
- **Video Memory Size -- 1.5M, 2.5M, 4.0M**
To select the size of video memory. It makes use of system memory for display.

4.10 SUPERVISOR PASSWORD AND USER PASSWORD

Supervisor Password sets a password that is used to protect your system and Setup Utility. Supervisor Password has higher priority than User Password. Once you setup the password, the system will always ask you to key-in password every time you enter the BIOS SETUP. If you enter the BIOS SETUP with Supervisor Password, you can choose every setup/option on the main menu but with User Password, you can only choose three setup/options (USER PASSWORD, SAVE & EXIT SETUP and EXIT WITHOUT SAVING). To disable these passwords, enter the BIOS SETUP room with Supervisor Password and then just press the <Enter> key instead of entering a new password when the 'Enter Password' prompt pop-up.

N.B. : if you forget the password, do the Clear/Reset CMOS procedure (see Section 2.5 Clear CMOS Setup)



5 SVGA Setup

5.1 Introduction

The WAFER-5820 is equipped with on-board LCD/VGA interface. The description below is its specifications and features:

5.1.1 Chipset

The WAFER-5820 uses a Cyrix CX5530 chipset as its SVGA controller. It is compatible with many common 18-bit LCD displays and traditional analog CRT monitors. The VGA BIOS supports LCD. Besides, it also accepts interlaced and non-interlaced analog monitors (color and monochrome VGA) with high-resolution quality while maintaining complete IBM VGA compatibility. But digital monitors (i.e. MDA, CGA, and EGA) can be NOT supported. Multiple frequency (multisync) monitors are operated as if they were analog monitors.

5.1.2 Display memory

Having 1.5 ~ 4 MB UMA memory, the VGA controller can make CRT displays or color panel displays perform with resolutions up to 1024 x 768 at 64 K colors. The display memory can be modified up to 4 MB in BIOS for true-color resolution of 1024 x 768.

5.1.3 Display drivers

1. Win95,98 drivers(VGA & Audio) in
Wafer-5820CD \ Geodevga95,98 \ National geode Win9x
Drivers1.2.exe
2. WinNT4.0 drivers in
Wafer-5820CD\Nt40Vga\

5.2 Further Information

For more detailed information about the PCI/SVGA installation in your WAFER-5820, including driver updates, troubleshooting instructions, please refer to the following webs which provide some resources you may need. If not find the information you need, please contact the support team:

Web site: <http://www.voxtechnologies.com>.



Audio

6.1 Introduction

With on-board audio interface, the WAFER-5820 can perform high-quality stereo sound and FM music synthesis (ESFM) by using the CX5530 audio controller. The audio interface has functions of recording, compressing, and playing back voice, sound, and music with a built-in mixer control. In addition, the on board audio interface supports the Plug and Play (PnP) standard and provides PnP configuration for audio, FM, and MPU-104 logical devices. It is compatible with AC97 version 2.0, voice, and music functions. The ESFM synthesizer is register compatible with the OPL3 and has extended capabilities.

6.1.1 Audio drivers

1. Installing software driver in Windows NT

The driver was provided from the CD utility.
WinNT4.0 Audio drivers in
Wafer-5820CD\Audio\

2. Installing software driver in Win95/98

The software drivers was supported from Windows 95/98,
please set up from.....
Win98\drivers\audio\cyrix\mgxsb16.inf

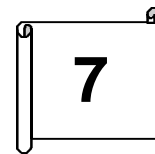

PCI Bus Ethernet Interface

7.1 Introduction

The WAFER-5820 provides a high performance 32-bit Ethernet chipset which is completely compliant with IEEE 802.3 100 Mbps CSMA/CD standards. It is both 100Base-T and 10Base-T compatible. The major network operating system fits it. The medium type can be set up via the RSET8139.exe program included on the utility CD.

The Ethernet port supplies a standard RJ-45 connector on board. To utilize the network boot feature is by incorporating the boot ROM image files for the appropriate network operating system. The boot ROM BIOS files are combined with system BIOS, which can be enabled/disabled in the BIOS setup.

The 8139x utility tools all in

WAFER-5820CD\8139x\

Appendix A. Watch-Dog Timer

The WatchDog Timer is a device to ensure that standalone systems can always recover from catastrophic conditions that cause the CPU to crash. This condition may have occurred by external EMI or a software bug. When the CPU stops working normally, hardware on the board will perform hardware reset (cold boot) to bring the system back to a known state.

Three I/O ports control the WatchDog Timer.

443	Write	Set Watch-Dog Time period
443 (hex)	Read	Enable the refresh the Watch-Dog Timer.
043/843 (hex)	Read	Disable the Watch-Dog Timer.

Prior to enable the Watch-Dog Timer, user has to define Timer first. The output data is a value of time interval and the range of the value is from 01(hex) to FF(hex) and time interval 1 sec to 255 sec.

Data	Time Interval
01	1 sec
02	2 sec
03	3 sec
04	4 sec
.	.
.	.
.	.
FF	255 sec

This will enable and activate the countdown timer which will eventually time out and reset the CPU to ensure that this reset condition does not occur, the Watch-Dog Timer must be

periodically refreshed by reading the same I/O port 043/843H and 443H. This must be done within the time out period that is selected by software, please refer to the example program.

A tolerance of at least 5% must be maintained to avoid unknown routines within the operating system (DOS), such as disk I/O that can be very time consuming. Therefore if the time out period has been set to 10 seconds, the I/O port 443H must be read within 7 seconds.

Note: when exiting a program it is necessary to disable the Watch-Dog Timer, otherwise the system will reset.

Example assembly program:

```
TIMER_PORT    = 443H
TIMER_START   = 443H
TIMER_STOP    = 843H
```

```
;;INITIAL TIME PERIOD COUNTER
MOV DX, TIME_PORT
OUT AL, 8:    ;;8 SECONDS

;;ADD YOUR APPLICATION HERE
MOV DX, TIMER_START
IN AL, DX.   ;;START COUNTER
```

```
;;ADD YOUR APPLICATION HERE
```

```
W_LOOP:
```

```
MOV DX, TIMER_STOP
```

```
IN AL, DX
```

```
MOV DX, TIMER_START
```

```
IN AL, DX.      ;;RESTART COUNTER
```

```
;;ADD YOUR APPLICATION HERE
```

```
CMP EXIT_AP, 0
```

```
JNE W_LOOP
```

```
MOV DX, TIMER_STOP
```

```
IN AL, DX
```

```
;;EXIT AP
```

Appendix B. I/O Address Map

B.1 System I/O Address Map

I/O Address Map	Description
000-01F	DMA Controller #1
020-021	Interrupt Controller # 1, Master
022-023	Chipset address
040-05F	System Timer
060-06F	Standard 101/102 keyboard Controller
070-07F	Real time Clock, NMI Controller
080-0BF	DMA Page Register
0A0-0BF	Interrupt Controller # 2
0C0-0DF	DMA Controller # 2
0F0-0F0	Clear Math Coprocessor Busy
0F1-0F1	Reset Math Coprocessor
0F8-0FF	Math Coprocessor
1F0-1F8	VIR BUS Master PCI IDE Controller
200-207	Game I/O
278-27F	Reserved
2F8-2FF	Serial Port 2
378-37F	Parallel Printer Port 1
3B0-3DF	Cyrix Graphic Adapter
3F0-3F7	Floppy Disk Controller
3F8-3FF	Serial Port 1
443	Watch dog timer enable
043/843	Watch dog timer disable

PNP audio I/O map range from 220~250H (16 bytes)

MPU-401 select from 300~330H (2 bytes)

B.2 DMA channel assignments

Channel	Function
0	Available
1	Audio*
2	Floppy disk (8-bit transfer)
3	Parallel**
4	Cascade for DMA controller 1
5	Audio*
6	Available
7	Available

* Audio DMA defaults setting: DMA 1.5

Audio High DMA select: DMA 1.3

Audio Low DMA select: DMA 5.6.7

** parallel port DMA default setting: DMA 3

parallel port DMA select: DMA 1.3

B.3 Interrupt assignments

Interrupt #	Interrupt source
NMI	Parity error detected
IRQ 0	System timer
IRQ 1	Keyboard
IRQ 2	Interrupt from controller 2 (cascade)
IRQ 8	Real-time clock
IRQ 9	Available
IRQ 10	Available
IRQ 11	Available
IRQ 12	PS/2 mouse
IRQ 13	Numeric data processor
IRQ 14	Fixed disk controller
IRQ 15	USB controller
IRQ 3	Available
IRQ 4	Serial communication port 1
IRQ 5	Audio*
IRQ 6	Diskette controller (FDC)
IRQ 7	Parallel port 1 (print port)

* Audio default setting: IRQ5

Ethernet IRQ is automatic set by the system

B.4 1st MB memory map

Address	Description
F000h-FFFFh	System ROM
D800h-EFFFh	Unused
C800h-D7FFh	Ethernet ROM*
C000h-C7FFh	Expansion ROM*
B800h-BFFFh	CGA/EGA/VGA text
B000h-B7FFh	Unused
A000h-AFFFh	EGA/VGA graphics
0000h-9FFFh	Base memory
D000-D400H	Available

* Default setting

** If Ethernet boot ROM is enabled.