

## 2600/2700 MAINSTREET FAMILY

DATA TERMINATION UNITS (DTUs)

Today's carriers recognize that improved service and competitive service pricing are key to maintaining customer loyalty. The equipment that is used to bring service to customer premises must also extend service benefits to those customers, while keeping operational costs to a minimum.

Alcatel offers a family of data termination units (DTUs) that are an integral part of the managed bandwidth solution. These DTUs are remotely software configurable, field proven, and offer advanced xDSL capabilities to extract the maximum performance from installed copper facilities.

The Alcatel DTUs provide enhanced data services over standard twisted pair copper into any TDM, frame relay or ATM network via Alcatel multiplexers. This fully managed suite of DTUs enables service providers to offer the solutions that their customers demand.



Enhanced data services  
over standard twisted  
pair copper



ALCATEL

ARCHITECTS OF AN INTERNET WORLD

## High Performance DTUs for Public Networks

Using Alcatel DTUs, service providers can offer network services at up to 1 Mb/s and distances of up to 7.2 km (4.5 mi.) over conventional, telephony-grade twisted pair wiring. Service providers find that these high performance DTUs increase their ability to deliver reliable, high speed data products and services directly to their customers as part of a fully managed service.

The multirate Alcatel 2801 MainStreet HDSL Data Termination Unit (DTU) provides a simple and economical vehicle to deliver data services at speeds of up to 1 Mb/s over a single pair of unconditioned copper wires. This solution is excellent for such applications as LAN interconnection, high speed extranet and intranet connections, and server connections for web hosting. HDSL provides the advantage of increased speed and distance, along with improved reliability, and is unaffected by bridge taps or changes in wire gauge.

The Alcatel 2700 MainStreet family of DTUs are extended range devices that operate at a distance of up to 7.2 km (4.5 mi.). These DTUs connect to 2B1Q or 27LC2 line cards in the 3600 MainStreet family of large multiplexers, and to interface modules on the full range of small muxes. They deliver data services to customer premises, often over external twisted pair cable with full line protection. Options include basic asynchronous data via V.24; increased speeds via V.35; redundant network connections; and incorporated routers. The 2700 DTUs provide maximum bandwidth, flexibility and management at minimal cost.

The Alcatel 2600 MainStreet family of DTUs provide a full suite of interfaces and options, including basic two-port V.24, eight-port V.24, two-port V.35, four-port FRADs (frame relay access devices), and special CPSS conversion units. The 2600 DTUs operate at a distance of up to 3 km (2 mi.) through a DNIC (data network interface circuit) line card connecting to the Alcatel node, and interface modules on some small muxes. These low cost DTUs deliver data services for on-premises, building riser and campus applications.

### The right choice

Automatic self-diagnostics, extensive functional displays, automatic reconfiguration of replaced units, performance statistics and many more features make the Alcatel DTUs the ideal choice for delivering high speed data services to customers. Features include:

#### Simple installation and field swaps

- ▼ simple installation, no on-site configuration required, all operating parameters are software configurable locally or remotely
- ▼ no jumpers or DIP switches to configure
- ▼ units replaced in the field are reconfigured automatically by the connected 3600 series multiplexer
- ▼ connector ports can be configured as DTE or DCE, and can accommodate synchronous or asynchronous data at a full range of speeds
- ▼ all substrate speeds are supported with efficient HCM (high capacity multiplexing) rate adaptation

▼ Figure 1: Frame relay connectivity using the 2614 DTU

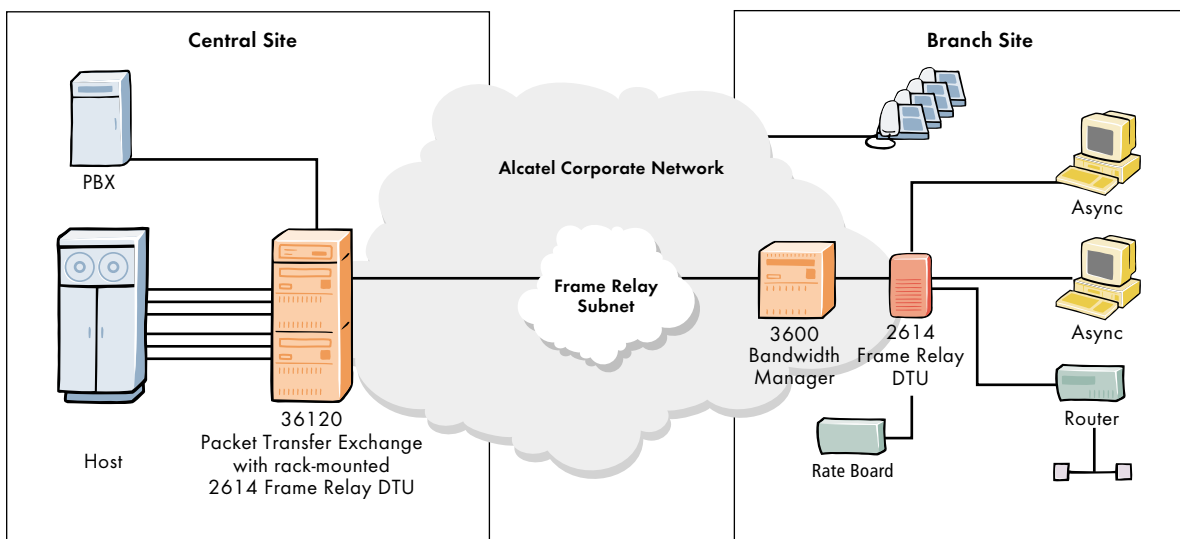

### Central management and maintenance

The Alcatel DTUs can be remotely managed from a 4602 MainStreet NetworkStation or Alcatel 5620 Network Manager (NM), formerly the 46020 Network Manager\*, offering the following functions:

- ▼ configuration (e.g. interface speed, parity)
- ▼ setting and monitoring the state of the control leads
- ▼ selection of rate adaptation parameters and control lead functions
- ▼ collection of performance statistics (Alcatel 2700 and 2800 MainStreet DTUs only)
- ▼ full set of loopbacks
- ▼ loss of synch alarms
- ▼ loss of power alarms (2751E MainStreet DTU, 2753E MainStreet DTU, 2801 DTU only, require 27LC2 or 28LC line cards)
- ▼ integral BERT (2801 DTU only)

### Special function DTUs

Two variants of the DTUs provide data services over frame relay starting right at the customer premises.

#### Frame relay connectivity — 2614 MainStreet Frame Relay DTU

The 2614 DTU is a high performance FRAD that is capable of adapting a wide variety of data traffic types to frame relay networks via Alcatel multiplexers. The 2614 has four V.24 ports, providing data access for up to four devices. See Figure 1.

#### Internet and LAN connectivity — 2720 and 2721 MainStreet Internet/Router Termination Units

The Alcatel 2720 MainStreet Internet Termination Unit and 2721 MainStreet Router Termination Unit were designed to address the growing demand for affordable alternatives in the expanding corporate intranet and Internet access markets. These units combine the capabilities of a router with the effective reliable access of a 2700 DTU to provide LAN access for one to multiple users over frame relay. See Figure 2.

▼ Figure 2: 2721 Router Termination Unit in a managed intranet application

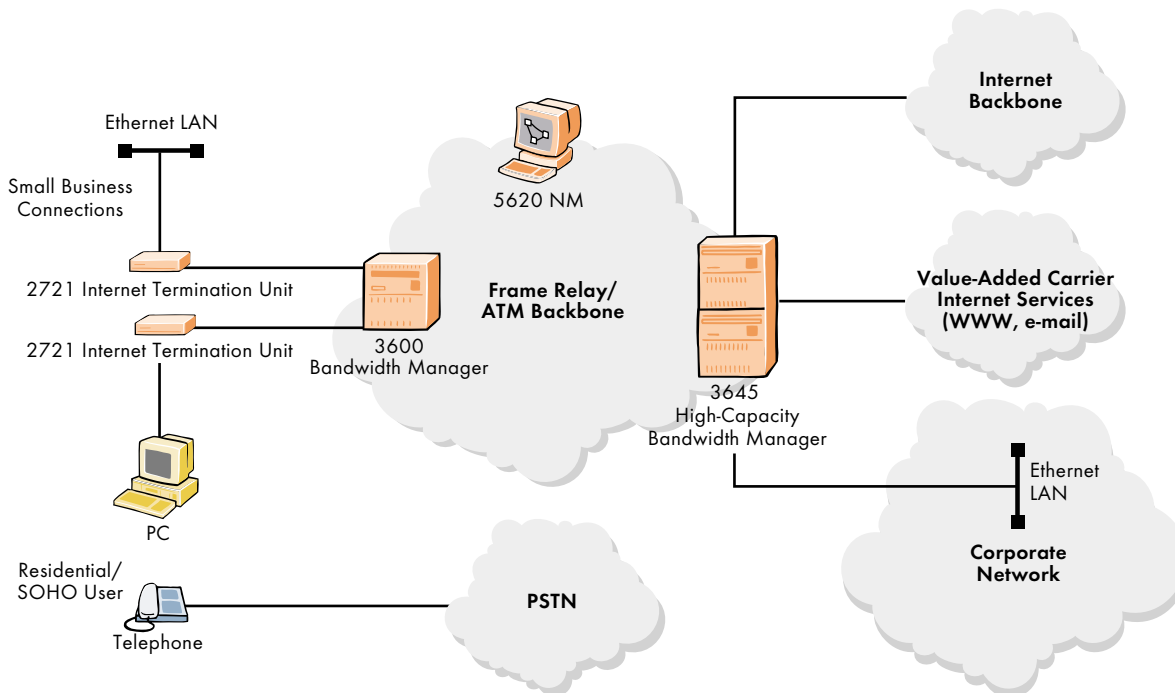

## Private network application

Supporting all of the features previously described for public networks, Alcatel DTUs are also effectively deployed in private and enterprise networks.

As a cost-effective method for extending data distribution and network access, Alcatel DTUs can exploit the existing twisted pair wiring infrastructure, thereby preventing the need to rewire with bulky and expensive data cabling or expensive fiber.

## MainStreet DTUs at work

Figure 3 provides several examples of MainStreet DTU applications functioning within a managed internetworking environment.

The 2700 series of DTUs at the top left of the diagram are extended range devices that connect to an Alcatel node. In this TDM application, they are functioning within a master/slave timing subsystem, wherein one station (master) supplies the timing reference for each interconnected station or node (slave) independent of the 3600 node system clock. Each 2700 node terminates a subrate circuit from the subrate multiplexer.

Beneath the 2700 DTUs, a 2801 is shown providing high speed (1 Mb/s) router access over one pair of unconditioned wires, without the need for repeaters.

In the X.25 application, the 2700 DTUs are shown terminating circuits from an X.25 network accessed via a 3630 MainStreet Primary Rate Multiplexer node.

In the multi-tenant building, several 2600 DTUs and a 2801 DTU are shown in a riser, on-premises application. These DTUs are providing connectivity to a centrally located 3600 node.

The 2720 Internet Termination Unit provides carrier-managed 128 kb/s Internet access without tying up a port on an ISDN switch.

The 2721 Router Termination Unit is shown in a small business LAN interconnect application. It contains a full IP/IPX router for mapping IP addresses to frame relay PVCs.

The 2753E DTUs are providing network redundancy for a mission-critical router. They are connected to different 2B1Q line cards.

### ▼ DTU Quick Reference Chart. It provides a quick reference of speeds and interfaces offered by each member of the Alcatel DTU family.

DTU loop†	Max. Port Speeds	Maximum Data	Interface Port Density	36LG	Notes
2601 2612	3.3 km (2 mi.)	64 kb/s	V.24 + V.24	six or 12 circuits per slot	2612 includes integral BERT
2602	3.3 km (2 mi.)	128 kb/s	X.21 + X.21	six or 12 circuits per slot	
2603 2613	3.3 km (2 mi.)	128 kb/s	V.35 + V.35	six or 12 circuits per slot	2613 includes integral BERT
2606	3.3 km (2 mi.)	64 kb/s	8 x V.24	six or 12 circuits per slot	TDM muxing
2610	3.3 km (2 mi.)	64 kb/s	2 x V.24	six or 12 circuits per slot	CPSS PAD
2614	3.3 km (2 mi.)	128 kb/s	4 x V.24	six or 12 circuits per slot	FRAD
2701 2751E	7.2 km (4.5 mi.)	64 kb/s	V.24 + V.24	six circuits per slot	2751E supports network redundancy 2751E-power fail detect††
2702	7.2 km (4.5 mi.)	128 kb/s	X.21 + X.21	six circuits per slot	
2703 2753E	7.2 km (4.5 mi.)	128 kb/s	V.35 + V.35	six circuits per slot	2753E supports network redundancy 2753E-power fail detect††
2704	7.2 km (4.5 mi.)	64 kb/s	V.24 + V.24	six circuits per slot	Supports V.110 rate adaption
2720 2721	7.2 km (4.5 mi.)	128 kb/s	10Base-T Ethernet (512 kb/s with compression)	six circuits per slot	IP routing (2720) IP and IPX routing (2721) power fail detect††
2801	7.3 km (4.6 mi.)	1 Mb/s	V.35, X.21 or V.36 (TIA/EIA-449)	six circuits per slot	Integral BERT power fail detect

† With 0.5 mm/24 gauge wire

†† When used with 27LC2

▼ Figure 3: DTU Applications

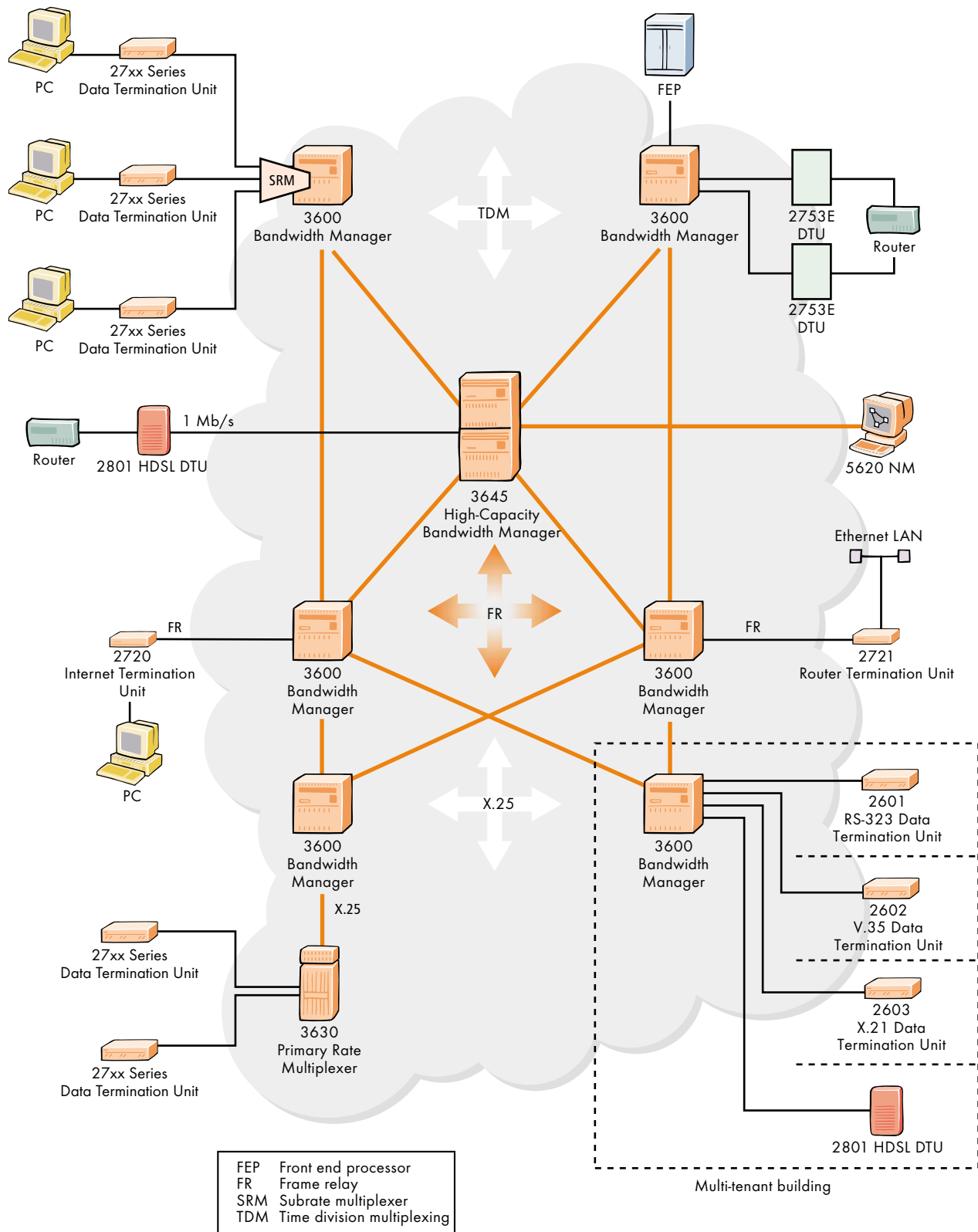

## Transmission performance

Extensive lab measurements have been performed to determine the maximum DTU operating distances over standard gauge twisted pair wire. Test results for the 2600 and 2700 series were performed as per ANSI T1.601, which injects noise during testing

to better simulate actual loop conditions. Testing for the 2801 series was performed according to ETSI specification ETR 152.

The 2801 DTU can run at several line rates and loop reaches, which provides service to customers outside the normal delivery range.

### ▼ Loop length versus wire gauge for the 2600 and 2700 DTUs

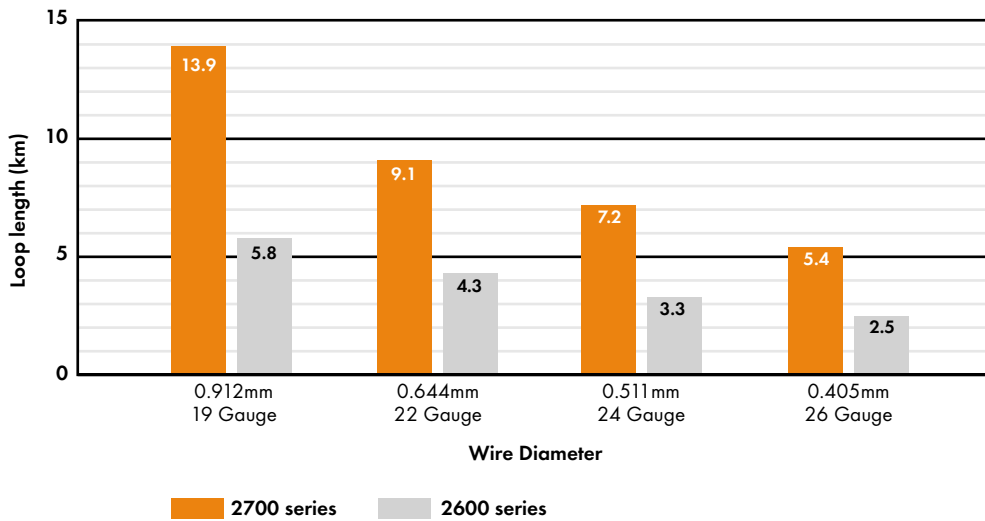

### ▼ Loop length versus wire gauge for the 2801 DTUs

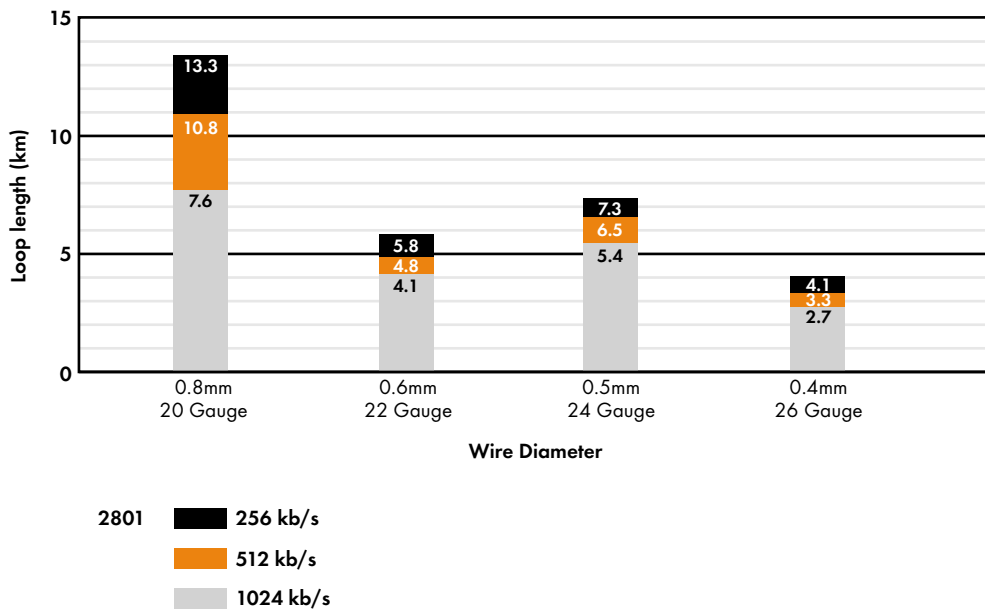

## Technical Summary

### Features

#### 2601/2612/2701/2751E MainStreet DTUs

- ▼ ports: dual V.24 / TIA/EIA-232
- ▼ connectors: DB25
- ▼ physical interface: TIA/EIA-232C, CCITT V.24/28
- ▼ mode of operation: DTE/DCE
- ▼ control signals supported: RTS, CTS, ALB, RDL, DCD, DSR, DTR, RI
- ▼ variable character length: nine, 10 or 11 (start, data, parity, stop bits)
- ▼ rate adaptation: HCM

#### 2602/2702 MainStreet DTUs

- ▼ ports: dual X.21/TIA/EIA-449
- ▼ connectors: DB15
- ▼ physical interface: TIA/EIA-449/442, CCITT X.21, ISO 4903
- ▼ mode of operation: DTE/DCE
- ▼ control signals supported: C, I
- ▼ variable character length: 9, 10 or 11 (start, data, parity, stop bits)
- ▼ rate adaptation: HCM

#### 2603/2703/2753E MainStreet DTUs

- ▼ ports: dual V.35
- ▼ connectors: DB25
- ▼ physical interface: CCITT V.35, ISO 2593
- ▼ mode of operation: DTE/DCE
- ▼ control signals supported: RTS, CTS, ALB, RDL, DCD, DSR, DTR, RI
- ▼ variable character length: nine, 10 or 11 (start, data, parity, stop bits)
- ▼ rate adaptation: HCM

#### 2704 MainStreet NTU

- ▼ ports: dual V.24/TIA/EIA-232
- ▼ connectors: DB25
- ▼ physical interface: TIA/EIA-232, CCITT V.24/28
- ▼ mode of operation: DTE/DCE
- ▼ variable character length: 9, 10 or 11 (start, data, stop bits)
- ▼ rate adaptation: CCITT V.110 (I.463) with E-bit support

#### 2801 HDSL DTU

- ▼ ports: one V.35 or X.21 or V.36/TIA/EIA-449 software selectable
- ▼ connector: DB37
- ▼ physical interfaces: V.35, V.36/TIA/EIA-449, X.21
- ▼ mode of operation: synchronous DCE
- ▼ control signals supported: DSR, DTR, RTS, CTS, DED, TM, SI
- ▼ rate adaptation: I.460

### Line Connection

- ▼ single twisted pair (2600, 2700, 2800)
- ▼ up to 4.1 km (2.6 mi.) using 26 AWG wire (2800)
- ▼ up to 5.4 km (3.4 mi.) using 26 AWG wire (2700)
- ▼ up to 2.5 km (1.6 mi.) using 26 AWG wire (2600)
- ▼ RJ-45 connector (2700 and 2800)
- ▼ RJ-11 connector (2600)
- ▼ transmission using adaptive echo cancellation techniques
- ▼ D channel used for control and management of the DTU

### System/Maintenance Features

- ▼ DTE/DCE software configurable (2801 HDSL DTU DCE only)
- ▼ synchronization software selectable
- ▼ data rates software selectable
- ▼ asynchronous and/or synchronous operation (2801 synchronous only)
- ▼ local, remote, channel and network loopbacks supported
- ▼ data performance statistics
- ▼ automatic self-diagnostics
- ▼ several clocking modes
- ▼ rate adaptation types
- ▼ power fail alarm (2751E, 2753E, 2801)
- ▼ integral BERT (2801)

### Physical Description

#### 2600/2700/2800 DTUs

- ▼ Height: 3.76 cm (1.48 in.)
- ▼ Width: 19.41 cm (7.64 in.)
- ▼ Depth: 26.67 cm (10.5 in.)
- ▼ Weight: 0.85 kg (1.8 lb.) excluding power adapter

#### 2720/2721 Internet/Router Termination Units

- ▼ Height: 3.71 cm (1.46 in.)
- ▼ Width: 21.6 cm (8.5 in.)
- ▼ Depth: 15.32 cm (6.03 in.)
- ▼ Weight: 0.59 kg (1.3 lb.) excluding power adapter

### Operating Environment

For 2720/2721:

- ▼ 5° to 40° C (41° to 104° F)
- ▼ 20% to 80% humidity noncondensing

For all other DTUs:

- ▼ 0° to 50° C (32° to 122° F)
- ▼ 5% to 95% humidity noncondensing

	Synchronous Data Rates	Asynchronous Data Rates
2601/2612/2701/2751E MainStreet	0.15, 0.3, 0.6, 0.8, 1.2, 1.6, 2.4, 4, 4.8, 7.2, 8, 9.6, 12, 14.4, 16, 16.8, 19.2, 24, 28.8, 32, 38.4, 40, 48, 56, 57.6 and 64 kb/s	0.15, 0.3, 0.6, 1.2, 1.8, 2.4, 4.8, 7.2, 9.6, 14.4, 19.2 and 38.4 kb/s
2602/03/06/10/13/14 2702/03/2753E MainStreet	0.15, 0.3, 0.6, 0.8, 1.2, 1.6, 2.4, 4, 4.8, 7.2, 8, 9.6, 12, 14.4, 16, 16.8, 19.2, 24, 28.8, 32, 38.4, 64 and 128 kb/s	0.15, 0.3, 0.6, 1.2, 1.8, 2.4, 4.8, 7.2, 9.6, 14.4, 19.2, 38.4, 40, 48, 56 and 57.6 kb/s
2704 MainStreet V.110	0.6, 1.2, 2.4, 4.8, 7.2, 9.6, 12, 14.4, 19.2, 48, 56 and 64 kb/s; plus 36, 38.4 and 57.6 kb/s	1.2, 2.4, 4.8, 7.2, 9.6, 12, 14.4 and 19.2; plus 36 kb/s
2801 MainStreet	64, 128, 192, 256, 320, 384, 448, 512, 576, 640, 704, 768, 832, 896, 960 and 1,024 kb/s	n/a

For more information [www.cid.alcatel.com](http://www.cid.alcatel.com)

Alcatel, the Alcatel logo, MainStreet and Newbridge are registered trademarks of Alcatel. All other trademarks are the property of their respective owners. Alcatel assumes no responsibility for the accuracy of the information presented, which is subject to change without notice.

© 2000 Alcatel. All rights reserved. 10346

3CL 00469 0075 TQZCA Ed.01

#### Product Safety

- ▼ IEC950
- ▼ CSA22.2 No. 950
- ▼ UL1950
- ▼ EN60 950
- ▼ AS/NZS 3260
- ▼ This product bears the CE Marking, and complies with the relevant CE Marking directives of the European Community.

#### EMC Standards

- ▼ ICES-003
- ▼ FCC Part 15
- ▼ EN55022
- ▼ EN50082
- ▼ CISPR22

#### Power

- ▼ 2600/2700: Alcatel AC-AC standard power adapters available: 115 V AC/60 Hz, 230 V AC/50 Hz. Alcatel DC-DC standard power adapter available: -24/-48 V DC
- ▼ 2751E, 2753E, 2801: Alcatel AC-DC standard power adapters available: 115 V AC/60 Hz, 230 V AC/50 Hz

#### Special Note

Interface speed is subject to speed of node. Please consult the 3600/3645 MainStreet Bandwidth Manager documentation for full interface speed compatibility.

\* This product belonged to the Newbridge family. Newbridge was acquired by Alcatel in May 2000.



ARCHITECTS OF AN INTERNET WORLD