

JUKI- 740E Pentium®
with LCD/CRT & Ethernet
PCISA SBC Ver 3.x

@Copyright 1999

All Rights Reserved.

Manual second edition Sep.08,1999

The information in this document is subject to change without prior notice in order to improve reliability, design and function and does not represent a commitment on the part of the manufacturer.

In no event will the manufacturer be liable for direct, indirect, special, incidental, or consequential damages arising out of the use or inability to use the product or documentation, even if advised of the possibility of such damages.

This document contains proprietary information protected by copyright. All rights are reserved. No part of this manual may be reproduced by any mechanical, electronic, or other means in any form without prior written permission of the manufacturer.

Trademarks

JUKI-740E is registered trademarks of ICP Electronics Inc. IBM PC is a registered trademark of International Business Machines Corporation. Intel is a registered trademark of Intel Corporation. AMI is registered trademarks of American Megatrends, Inc. Other product names mentioned herein are used for identification purposes only and may be trademarks and/or registered trademarks of their respective companies.

Contents

1. Introduction	3
1.1 Specifications	4
1.2 What You Have	6
2. Installation	7
2.1 JUKI-740E Layout.....	7
2.2 Setting the CPU of JUKI-740E	9
2.3 Watch-Dog Timer	11
2.4 DiskOnChip™ Flash Disk.....	12
2.5 LCD Voltage Setting	12
2.6 Clear CMOS Setup	12
2.7 Battery Backup for CMOS Setup.....	13
2.8 BIOS Flash Chip Write Voltage Setting	13
3. Connection	14
3.1 Floppy Disk Drive Connector.....	14
3.2 PCI E-IDE Disk Drive Connector	15
3.3 Parallel Port.....	16
3.4 Serial Ports.....	16
3.5 Keyboard/Mouse Connector	17
3.6 External Switches and Indicators	18
3.7 External Battery Connector	19

3.8	LCD/CRT Connector	19
3.9	Lan RJ45 Connector	20
3.10	USB Port	21
3.11	IO Address Map.....	21
4.	AMI BIOS Setup	24
4.1	Getting Start	24
4.2	Standard CMOS Setup	25
4.3	Advanced CMOS Setup	25
4.4	Advanced Chipset Setup.....	26
4.5	Peripheral Setup	27
4.6	Power Management Setup.....	28
5.	E²Key Function	29
	Appendix A. Watch-Dog Timer.....	31
	Appendix B. FP24-01 Module.....	32
	Appendix C. Support Panel List.....	34

1

Introduction

Welcome to the JUKI-740E Pentium® with HiQPro™ LCD/CRT and Ethernet Single Board Computer. The JUKI-740E board is an PCISA form factor board, which comes equipped with high performance Pentium® CPU and advanced high performance multi-mode I/O, designed for the system manufacturers, integrators, or VARs that want to provide all the performance, reliability, and quality at a reasonable price.

This board built-in DiskOnChip™ (DOC) Socket for embedded application. The DOC Flash Disk is 100% software compatible to hard disk. User can use any DOS command without any extra software utility. The DOC currently is available from 2MB to 144MB.

The on board RTL8139 network chipset provides 10Mbps or 100Mbps Ethernet with auto-sensing function.

In addition, the JUKI-740E built-in C&T 65555 HiQPro™ LCD/CRT Chipset and 2MB EDO RAM. The LCD interface can drive up to 1280x1024 with 256 colors. The support flat panel will cover Mono, Color STN, TFT, EL,..etc. and also 3.3V or 5V version.

1.1 Specifications :

The JUKI-740E Pentium® with HiQPro™ LCD/CRT & Ethernet Single Board Computer provides the following specification:

- **CPU** : Pentium® MMX up to 233Mhz, AMD K6 processor up to 350MHz, Cyrix 6x86MX and IDT C6 processor
- **PCISA Bus** : ISA bus and PCI 32-bit local bus, PCI 2.1 standard
- **Chipset** : ALI M1531/M1543
- **LCD/CRT Interface** : C&T 65555 Chipset with 2MB EDO RAM
CRT Resolution : 1280x1024,256 colors
1024x768, 64K colors
800x600, 16M colors
36-bit LCD Interface Resolution :
1280x1024,256 colors
1024x768, 64K colors
800x600, 16M colors

Please contact www.chips.com to get more information.

- **Ethernet** : RTL 8139 Chipset
IEEE 802.3u 10BASE-TX standard
Auto-sensing interface to 10Mbps or 100Mbps networks
Full duplex capability
More information : www.realtek.com.tw
- **Real-time clock/calendar** : in ALI 4+ chipset, backup by industrial Li-battery,3V/850mAH.
- **RAM memory** : up to 128MB EDO RAM
- **Second Cache memory** : 512KB Pipelined Burst SRAM on board
- **Ultra DMA/33 IDE Interface** : up to four PCI Enhance IDE hard drives. The Ultra DMA/33 IDE can handle data transfer up to 33MB/s. The best of all is that is new technology is compatible with existing ATA-2 IDE specifications. So there is no need to do any change for customer's current accessory.
- **Floppy disk drive interface** : two 2.88 MB, 1.44MB, 1.2MB, 720KB, or 360KB floppy disk drives.

- **Two high speed Serial ports** : NS16C550 compatible UARTs
- **Bi-directional Parallel Port**
- **Watch-dog timer** : can be set by 1,2,10,20,110 or 220 seconds period. Reset or NMI was generated when CPU did not periodically trigger the timer. Your program use hex 843 and 443 to control the watch-dog and generate a system reset.
- **Flash Disk - DiskOnChip™** : The Flash Disk provide 100% compatible with hard disk. The built-in TrueFFS Transparent Flash Block Management and Space Reclamation will let customer to use the Flash Disk with DOS command, no need any extra software utility.
- **Keyboard connector**
- **USB Port** : support one USB port for future expansion.
- **Mouse** : PS/2 Mouse Port on-board.
- **Power Consumption** : +5V @ 5A
 (MMX-233,32MB EDO RAM)
 +12V @ 170mA , -12V@20mA
- **Operating Temperature** : 0° ~ 55°C (CPU needs Cooler)

1.2 What You Have

In addition to this *User's Manual*, the JUKI-740E package includes the following items:

- JUKI-740E Pentium® with HiQPro™ LCD/CRT & Ethernet Single Board Computer
- RS-232/Printer Cable
- FDD/HDD Cable
- 6-pin Mini-Din to 5-pin Din Keyboard and Mouse Adapter Cable

If any of these items is missing or damaged, contact the dealer from whom you purchased the product. Save the shipping materials and carton in case you want to ship or store the product in the future.

2

Installation

This chapter describes how to install the JUKI-740E. At first, the layout of JUKI-740E is shown, and the unpacking information that you should be careful is described. The jumpers and switches setting for the JUKI-740E's configuration, such as CPU type selection, system clock setting, and watch dog timer, are also included.

2.1 JUKI-740E Layout

< reference next page >

2.1 JUKI-740E Layout

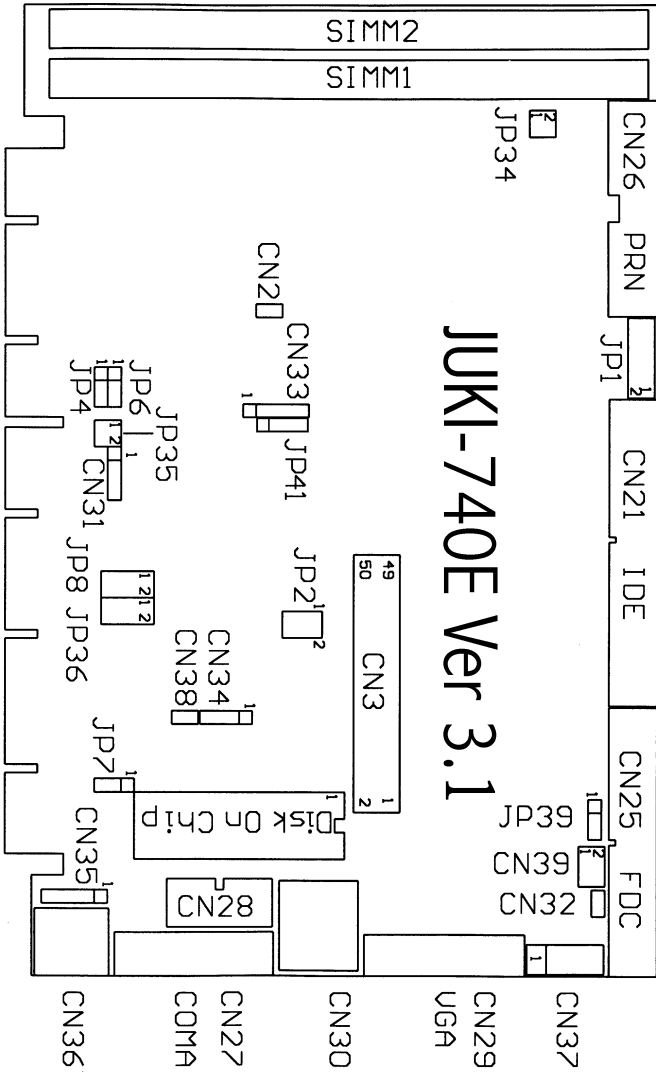

2.2 Setting the CPU of JUKI-740E

JP1: BUS Clock & CPU CORE/BUS Freq ratio setting

• CPU Clock Setting :

S2 11-12	S1 9-10	S0 1-2	CPU/SDRQAM CLK (MHz)	PCI BUS CLK (MHz)
OFF	OFF	OFF	66.8	33.4
OFF	OFF	ON	60	30
OFF	ON	OFF	75	37.5
OFF	ON	ON	55	27.5
ON	OFF	OFF	68.5	34.25
ON	OFF	ON	83.3	33.3
ON	ON	OFF	75	30
ON	ON	ON	83.3	41.65

• FREQ RATIO :

BF2 7-8	BF1 5-6	BF0 3-4	RATIO
OFF	OFF	OFF	1.5 X
OFF	OFF	ON	2.0 X
OFF	ON	ON	2.5 X
OFF	ON	OFF	3.0X
OFF	OFF	OFF	3.5 X
ON	OFF	ON	4.0 X
ON	ON	ON	4.5 X
ON	ON	OFF	5.0 X
ON	OFF	OFF	5.5 X

**CPU Frequency = CPU Clock x Ratio for example
Pentium® 200MHz = 66MHz CPU Clock x 3**

• CPU Core Voltage Selection :

Please check the CPU Core Voltage before you install the CPU. Right now new Intel MMX CPU is dual voltages for core and I/O, the I/O is 3.3V but the core is 2.8V. This kind of CPU design will enhance the low power consumption capability. As for the general Pentium CPU is one voltage for I/O and Core - 3.3V,3.4V, or 3.5V

. Power module JP1: CPU VCORE Voltage select

1-2	3-4	5-6	7-8	9-10	Voltage
ON	ON	ON	ON	OFF	3.5V
OFF	ON	ON	ON	OFF	3.4V
OFF	OFF	ON	ON	OFF	3.2V
ON	OFF	OFF	ON	OFF	2.9V
OFF	OFF	OFF	ON	OFF	2.8V
OFF	ON	OFF	OFF	OFF	2.2V
OFF	OFF	OFF	OFF	OFF	2.0V

. JP34 & JP35: CPU Single/Dual Power type setting

	JP34	JP35
SINGLE	1-2 ON 3-4 ON	1-2 OFF 3-4 OFF
DUAL	1-2 OFF 3-4 OFF	1-2 ON 3-4 ON

**. Cyrix 6x86MX PR Rating Table
(Vcore : 2.9V,dual voltage)**

PR Rating	Bus MHz	CPU Core MHz	Clock Multiplier
6x86MX-PR133	50	100	2x
6x86MX-PR133	55	110	2x
6x86MX-PR150	60	120	2x
6x86MX-PR150	50	125	2.5x
6x86MX-PR166	66	133	2x
6x86MX-PR166	55	138	2.5x
6x86MX-PR166	50	150	3x
6x86MX-PR166	60	150	2.5x
6x86MX-PR200	55	165	3x
6x86MX-PR200	66	166	2.5x
6x86MX-PR200	60	180	3x
6x86MX-PR233	66	200	3x
6x86MX-PR266	66	233	3.5x

• **AMD K6 MMX Rating Table, dual voltage**

Product Name	Core Freq	Vcore	Bus MHz	Multiplier
K6-233 model 6	233MHz	3.2V	66	3.5x
K6-200 model 6	200MHz	2.9V	66	3x
K6-166 model 6	166MHz	2.9V	66	2.5x
K6-300 model 7	300MHz	2.2V	66	4.5x
K6-266 model 7	266MHz	2.2V	66	4x
K6-233 model 7	233MHz	2.2V	66	3.5x

2.3 Watch-Dog Timer

The Watch-Dog Timer is enabled by reading port 443H. It should be triggered before the time-out period ends, otherwise it will assume the program operation is abnormal and will issue a reset signal to start again, or activate NMI to CPU. The Watch-Dog Timer is disabled by reading port 843H.

• **JP7 : WDT Function Type setting**

1-2	NMI
2-3	RESET

• **JP8: WDT setting**

TIMER	1-2	3-4	5-6	7-8
1 SEC	OFF	OFF	ON	OFF
2 SEC	OFF	OFF	ON	ON
10 SEC	OFF	ON	OFF	OFF
20 SEC	OFF	ON	OFF	ON
110 SEC	ON	OFF	OFF	OFF
220 SEC	ON	OFF	OFF	ON

2.4 DiskOnChip™ Flash Disk

The DiskOnChip™ Flash Disk Chip (DOC) is produced by M- Systems. Because the DOC is 100% software compatible to hard disk and DOS. Customer don't need any extra software utility. It is just "plug and play", easy and reliable. The share memory window is 8KB.

• JP36 : DOC Address setting

1-2	CE000
3-4	D6000
5-6	DE000
7-8	RESERVE

2.5 LCD Voltage Setting

The JUKI-740E supports 3.3V or 5V LCD panel by jumper setting. The setting will control the CN3's Pin 29 & 30 as 3.3V or 5V output.

• JP39 : LCD VDD Select

1-2	+3.3V
2-3	+5V

2.6 Clear CMOS Setup

If want to clear the CMOS Setup (for example forgot the password you should clear the setup and then set the password again.), you should close the CN34 pin 2-3 about 3 seconds, then open again. Set back to normal operation mode, close pin 2-3.

• CN34 : Clear CMOS Setup (Reserve Function)

CN34	DESCRIPTION
2-3	Normal Operation
3-4	Clear CMOS Setup

2.7 Battery Backup for CMOS Setup

There have one 4-pin header CN34 using for battery backup function. When close the pin 2-3 will use the on board battery. When use external battery you should take off the jumper and use the connector as external battery connector.

- **CN34: Battery Backup Function**

CN34	DESCRIPTION
2-3 CLOSE	Using Internal Battery
Connect Battery to Pin 1-4	Use as External Battery Connector

2.8 BIOS Flash Chip Write Voltage Setting

The BIOS Flash Chip could be two types, one is 12V write voltage and other one is 5V.

Please note the jumper is setting by production people.

- **JP2: Flash ROM setting**

Flash ROM Voltage		Flash ROM Size	
1-3	+12V	2-4	1MB
3-5	+5V	4-6	2MB

3

Connection

This chapter describes how to connect peripherals, switches and indicators to the JUKI-740E board.

3.1 Floppy Disk Drive Connector

JUKI-740E board equipped with a 34-pin daisy-chain driver connector cable.

• CN25 : FDC CONNECTOR

PIN NO.	DESCRIPTION	PIN NO.	DESCRIPTION
1	GROUND	2	REDUCE WRITE
3	GROUND	4	N/C
5	GROUND	6	N/C
7	GROUND	8	INDEX#
9	GROUND	10	MOTOR ENABLE A#
11	GROUND	12	DRIVE SELECT B#
13	GROUND	14	DRIVE SELECT A#
15	GROUND	16	MOTOR ENABLE B#
17	GROUND	18	DIRECTION#
19	GROUND	20	STEP#
21	GROUND	22	WRITE DATA#
23	GROUND	24	WRITE GATE#
25	GROUND	26	TRACK 0#
27	GROUND	28	WRITE PROTECT#
29	GROUND	30	READ DATA#
31	GROUND	32	SIDE 1 SELECT#
33	GROUND	34	DISK CHANGE#

3.2 PCI E-IDE Disk Drive Connector

You can attach two IDE(Integrated Device Electronics) hard disk drives to the JUKI-740E IDE controller. The IDE support Ultra DMA/33 interface.

• CN21: IDE Interface Connector

PIN NO.	DESCRIPTION	PIN NO.	DESCRIPTION
1	RESET#	2	GROUND
3	DATA 7	4	DATA 8
5	DATA 6	6	DATA 9
7	DATA 5	8	DATA 10
9	DATA 4	10	DATA 11
11	DATA 3	12	DATA 12
13	DATA 2	14	DATA 13
15	DATA 1	16	DATA 14
17	DATA 0	18	DATA 15
19	GROUND	20	N/C
21	IDE DRQ	22	GROUND
23	IOW#	24	GROUND
25	IOR#	26	GROUND
27	IDE CHRDY	28	GROUND
29	IDE DACK	30	GROUND
31	INTERRUPT	32	N/C
33	SA1	34	N/C
35	SA0	36	SA2
37	HDC CS0#	38	HDC CS1#
39	HDD ACTIVE#	40	GROUND

3.3 Parallel Port

This port is usually connected to a printer, The JUKI-740E includes an on-board parallel port, accessed through a 26-pin flat-cable connector CN26.

• **CN26 : Parallel Port Connector**

PIN NO	DESCRIPTION	PIN NO	DESCRIPTION
1	STORBE#	14	AUTO FORM FEED#
2	DATA 0	15	ERROR#
3	DATA 1	16	INITALIZE
4	DATA 2	17	PRINTER SELECT LN#
5	DATA 3	18	GROUND
6	DATA 4	19	GROUND
7	DATA 5	20	GROUND
8	DATA 6	21	GROUND
9	DATA 7	22	GROUND
10	ACKNOWLEDGE	23	GROUND
11	BUSY	24	GROUND
12	PAPER EMPTY	25	GROUND
13	PRINTER SELECT	26	NC

3.4 Serial Ports

The JUKI-740E offers two high speed NS16C550 compatible UARTs with Read/Receive 16 byte FIFO serial ports.

• **CN27 : Serial Port DB-9 Connector(COM1)**

PIN NO.	DESCRIPTION
1	DATA CARRIER DETECT (DCD)
2	RECEIVE DATA (RXD)
3	TRANSMIT DATA (TXD)
4	DATA TERMINAL READY (DTR)
5	GROUND (GND)
6	DATA SET READY (DSR)
7	REQUEST TO SEND (RTS)
8	CLEAR TO SEND (CTS)
9	RING INDICATOR (RI)

• **CN28 : Serial Port 10-pin Header(COM2)**

PIN NO.	DESCRIPTION
1	DATA CARRIER DETECT (DCD)
2	RECEIVE DATA (RXD)
3	TRANSMIT DATA (TXD)
4	DATA TERMINAL READY (DTR)
5	GROUND (GND)
6	DATA SET READY (DSR)
7	REQUEST TO SEND (RTS)
8	CLEAR TO SEND (CTS)
9	RING INDICATOR (RI)
10	NC

3.5 Keyboard / Mouse Connector

The JUKI-740E provides two keyboard/Mouse connectors.

• **CN37 : 5-pin Header Keyboard Connector**

PIN NO.	DESCRIPTION
1	KEYBOARD CLOCK
2	KEYBOARD DATA
3	N/C
4	GROUND
5	VCC

• **CN35 : PS/2 Mouse Connector**

PIN NO.	DESCRIPTION
1	MOUSE DATA
2	N/C
3	GROUND
4	VCC
5	MOUSE CLOCK

• **CN36 : PS/2 Keyboard/Mouse connector**

1	KBDATA
2	MSDATA
3	GROUND
4	VCC
5	KBCLK
6	MSCLK

• **CN33: Keylock & Power LED connector**

1	VCC
2	NC
3	GND
4	KEYLOCK
5	GROUND

3.6 External Switches and Indicators

There are many external switches and indicators for monitoring and controlling your CPU board.

• **CN2: Speaker Connector**

PIN NO.	DESCRIPTION
1	+5V
2	Speaker Signal

• **CN38 : Reset Connector**

PIN NO.	DESCRIPTION
1	External Reset
2	GROUND

• **CN32 : IDE LED Connector**

PIN NO.	DESCRIPTION
1	+5V
2	HDD LED

• **CN24 : CPU Fan Connector**

PIN NO.	DESCRIPTION
1	N/C
2	+12V
3	GROUND

3.7 External Battery Connector

The JUKI-740E built-in a 3V/850mAH industrial Li-battery for CMOS and RTC backup. When normal operation will not need external battery to backup the data. If want to connect the external battery you could take off the CN34 's pin 2-3 jumper. Then connect the external battery to pin 1-4.

• **CN34 : External Battery Connector**

1	External battery +
2	Internal battery +
3	To CMOS power (Note: 2-3 ON, use Internal battery)
4	GROUND (Note: 3-4 ON, Clear CMOS)

3.8 LCD/CRT Connector

The JUKI-740E built-in 15-pin VGA connector directly to your CRT monitor. And the built-in 50-pin connector for LCD interface.

• **CN29 : VGA connector**

1	RED
2	GREEN
3	BLUE
4,9,11	NC
5-8,10	GROUND
12	DDDA
13	H-SYNC
14	V-SYNC
15	DDCK

• **CN3 : 50-pin LCD Interface Connector**

1	VPCLK	2	P33
3	P34	4	P31
5	P35	6	P32
7	P30	8	P28
9	P29	10	P27
11	P25	12	P26
13	P24	14	P21
15	P23	16	P22
17	P16	18	P20
19	P17	20	P18
21	P19	22	P14
23	P13	24	P12
25	P15	26	P11
27	P7	28	P10
29	PLCD	30	PLCD
31	P9	32	P8
33	P4	34	P6
35	P3	36	P5
37	P2	38	P1
39	M	40	P0
41	SHFCLK	42	ENABLK
43	FPVDD	44	FLM
45	FPVEE	46	LP
47	GND	48	GND
49	+12V	50	+12V

3.9 Lan RJ45 Connector

The JUKI-740E built-in a RJ45 Lan connector..

• **CN30 : Lan RJ45 Connector**

1	TX+	5.	NC
2	TX-	6.	RX-
3.	RX+	7.	NC
4.	NC	8.	NC

• **CN31: IrDA port**

1	+5V
2	NC
3	RXD2B
4	GROUND
5	TXD2
6	NC

• **CN39 : LAN signal connector**

2	LED2: 10M
4	LED1: 100M
6	LED0: TX/RX

(Note: 1,3,5: VCC)

3.10 USB Port

The JUKI-740E built-in one USB port for the future new I/O bus expansion.

• **JP41: USB Port**

PIN NO.	DESCRIPTION
1	VCC
2	USBP0-
3	USBP0+
4	GROUND

3.11 IO Address Map

IO Address Map

I/O Address Range	Description
000-01F	DMA Controller #1
020-021	Interrupt Controller #1, Master
040-05F	8254 timer
060-06F	8042 (Keyboard Controller)
070-07F	Real time Clock, NMI (non-maskable interrupt) Mask
080-09F	DMA Page Register
0A0-0BF	Interrupt Controller #2
0C0-0DF	DMA Controller #2
0F0	Clear Math Coprocessor Busy
0F1	Reset Math Coprocessor
0F8-0FF	Math Coprocessor
1F0-1F8	Fixed Disk
200-207	Game I/O
278-27F	Parallel Printer Port 2 (LPT3)
2E8-2EF	Serial Port 4
2F8-2FF	Serial Port 2
300-31F	Prototype Card
360-36F	Reserved
378-37F	Parallel Printer Port 1 (LPT2)
380-38F	SDLC,Bisynchronous 2
3A0-3AF	Bisynchronous 1
3B0-3BF	Monochrome Display and Printer Adapter (LPT1)
3C0-3CF	Reserved
3D0-3DF	Color/Graphics Monitor Adapter

3E8-3EF	Serial Port 3
3F0-3F7	Diskette Controller,ALI1543 SIO CONFIG INDEX PORT(3F0)
3F8-3FF	Serial Port 1
443	Watch dog timer enable
843	Watch dog timer disable

1st MB Memory Address Map

Memory address	Description
00000-9FFFF	System memory
A0000-BFFFF	VGA buffer
C0000-CBFFF	VGA BIOS
*D6000-DA000	DOC 2000
E0000-FFFFFF	System BIOS
1000000-	Extend BIOS

*Default setting

IRQ Mapping Chart

IRQ0	System Timer	IRQ8	RTC clock
IRQ1	Keyboard	IRQ9	Unused
IRQ2	Cascade to IRQ Controller	IRQ10	Unused
IRQ3	COM2/COM4	IRQ11	Unused
IRQ4	COM1/COM3	IRQ12	PS2 mouse
IRQ5	Unused	IRQ13	FPU
IRQ6	FDC	IRQ14	Primary IDE
IRQ7	Printer	IRQ15`	Secondary IDE

DMA Channel Assignments

Channel	Function
0	Available
1	Available
2	Floppy disk (8-bit transfer)
3	Available
4	Cascade for DMA controller 1
5	Available
6	Available
7	Available

4

AMI BIOS Setup

The JUKI-740E uses the AMI BIOS for system configuration. The AMI BIOS setup program is designed to provide maximum flexibility in configuring the system by offering various options which may be selected for end-user requirements. This chapter is written to assist you in the proper usage of these features.

4.1 Getting Start

When power on the system, the BIOS will enter the Power-On-Self-Test routines. These routines will be executed for system test and initialization and system configuration verification. After the POST routines are completed, the following message appears :

" Hit DEL if you want to run SETUP"

To access AMI BIOS Setup program, press key, then you could see the screen to make some options as follows,

When choose **Load BIOS Defaults** will load the minimized settings for Troubleshooting. The performance should be very poor when use this setting.

When choose **Load Setup Defaults** will load optimized defaults for regular use. Choosing this setting, will modify all applicable settings.

4.2 Standard CMOS Setup

The Standard CMOS Setup is used for basic hardware system configuration. The main function is for Date/Time setting and Floppy/Hard Disk Drive setting. Please refer the following screen for this setup.

For IDE hard disk drive setup, please check the following possible setup procedure,

1. Use the Auto setting for detection during bootup.
2. Use the IDE HDD AUTO DETECTION in the main menu to automatically enter the drive specifications.
3. Manually enter the specifications by yourself from the "User" option.

4.3 Advanced CMOS Setup

This Advanced CMOS Setup is designed for customer's tuning best performance of the JUKI-740E board. As for normal operation customers don't have to change any default setting.

The default setting is pre-set for most reliable operation.

You also can option the system keyboard, primary display, PS/2 mouse to enable or disable.

The system boot sequence is also set here by first, second, third and fourth boot device setting.

4.4 Advanced Chipset Setup

This setup functions are almost working for ChipSet (ALI 4+). These options are used to change the ChipSet's registers. Please carefully change any default setting, otherwise the system could be running un-stable.

Auto Configuration : Enable or Disable

When use the 60nS general type DRAM, please enable the setting to get the optimal timings.

DRAM Speculative Read : Enable or Disable

When enable this option, the CPU will send predict commands to the SDRAM, if a miss happens, the CPU will cancel this command. Because some OS under certain situations have problem for this feature, it is normally disable.

USB function: Disabled

USB Keyboard/Mouse Legacy Support: Disabled

AMIBIOS SETUP - ADVANCED CHIPSET SETUP (C)1996 American Megatrends, Inc. All Rights Reserved		
USB Function	Disabled	Available Options: Disabled Enabled
USB Keyboard/Mouse Legacy Support	Disabled	
DRAM Write Timing	4-3-3-3	
Page Mode DRAM Read Timing	X-4-4-4	
RAS Precharge Period	4T	
RAS to CAS Delay Time	3T	
EDO DRAM Read Timing	X-3-3-3	
DRAM Speculative Read	Disabled	
SDRAM CAS Latency	3	
SDRAM Timing	3-6-9	
SDRAM Speculative Read	Disabled	
Pipe Function	Disabled	
Gated_Clock	Disabled	
Slow Refresh	15 us	
DRAM Data Integrity Mode	Disabled	
Primary Frame Buffer	Disabled	
UGA Frame Buffer	Disabled	
Passive Release	Disabled	
ISA Line Buffer	Disabled	
Delay Transaction	Disabled	
		ESC:Exit ↑:Sel PgUp/PgDn:Modify F2/F3:Color

4.5 Peripheral Setup

This setup is almost working for Multi-I/O Chip(W83877F and ALI Alladin 4+ chipset). These options are used to change the ChipSet's registers. Please carefully change any default setting to meet your application need perfectly. The only special concern is Onboard Serial Port2. If you are using the IrDA port, you have to set this port accordingly.

The most important setting in this setup is **LCD Type setting**. In the most right bottom item – Panel Type selection, customer can choose 15 different panel type. The 15 panel types are :

1. 1024x768 Dual Scan STN Color
2. 1280x1024 TFT
3. 640x480 STN
4. 800x600 STN
5. 640x480 TFT
6. 640x480 18bit
7. 1024x768 TFT
8. 800x600 TFT
9. 800x600 TFT
10. 800x600 TFT
11. 800x600 STN
12. 800x600 STN
13. 1024x768 TFT
14. 1280x1024 STN
15. 1024x600 STN

4.6 Power Management Setup

Power Management Setup help user handles the JUKI-740E board's "green" function. The features could shut down the video display and hard disk to save energy for example. The power management setup screen is as following,

**Power Management/APM : Disable, Max Saving, Min Saving,
or User Defined**

Note : Advanced Power Management(APM) have to be installed to keep the system time updated when the computer enters suspend mode activated by the Power Management.

Under DOS environment, you need to add

DEVICE=C:\DOS\POWER.EXE in your CONFIG.SYS

Under Windows 3.x and Windows 95,you have to install Windows with APM feature. A battery and power cord icon labeled "Power"

Will appear in the "Control Panel"

5

E² Key™ Function

The JUKI-740E provides an outstanding E²KEY™ function for system integrator. Based on the E²KEY™ you could free to store the ID Code, Pass Word, or Critical Data in the 1Kbit EEPROM. Because the EEPROM is nonvolatile memory, you don't have to worry the losing of the very important data.

Basically the E²KEY™ is based on a 1Kbit EEPROM which is configured to 64 words(from 0 to 63). You could access(read or write) each word at any time.

When you start to use the E²KEY™ you should have the utility in the package. The software utility will include four files as follows,

README.DOC
E2KEY.OBJ
EKEYDEMO.C
EKEYDEMO.EXE.

The E2KEY.OBJ provides two library function for user to integrate their application with E²KEY™ function. These library (**read_e2key** and **write_e2key**) are written and compiled in C format. Please check the following statement, then you will know how to implement it easily.

unsigned int read_e2key(unsigned int address)

/* This function will return the E²KEY™'s data at address. The address range is from 0 to 63. Return data is one word,16 bits */

void write_e2key(unsigned int address, unsigned data)

/* This function will write the given data to E²KEY™ at address. The address range is from 0 to 63. The data value is from 0 to 0xffff. */

To easy start to use the function, please refer the include EKEYDEMO.C code at first.

Please note the E²KEY™ function is based on the working of parallel port. So you should enable the JUKI-740E's parallel port, otherwise will be not working.

Appendix A. Watch-Dog Timer

The Watch-Dog Timer is provided to ensure that standalone systems can always recover from catastrophic conditions that caused the CPU to crash. This condition may have occurred by external EMI or a software bug. When the CPU stops working correctly, hardware on the board will either perform a hardware reset (cold boot) or a non-maskable interrupt (NMI) to bring the system back to a known state.

The Watch-Dog Timer is controlled by two I/O ports.

443 (hex)	Read	Enable the refresh the Watch-Dog Timer.
843 (hex)	Read	Disable the Watch-Dog Timer.

To enable the Watch-Dog Timer, a read from I/O port 443H must be performed. This will enable and activate the countdown timer which will eventually time out and either reset the CPU or cause an NMI depending on the setting of JP7. To ensure that this reset condition does not occur, the Watch-Dog Timer must be periodically refreshed by reading the same I/O port 443H. This must be done within the time out period that is selected by jumper group JP8.

A tolerance of at least 30% must be maintained to avoid unknown routines within the operating system (DOS), such as disk I/O that can be very time consuming. Therefore if the time out period has been set to 10 seconds, the I/O port 443H must be read within 7 seconds.

Note: when exiting a program it is necessary to disable the Watch-Dog Timer, otherwise the system will reset.

Appendix B. FP24-01 Flat Panel Connection Module

The FP24-01 connection module is installed on the JUKI-740E as a standard product. The FP24-01 converts JUKI-740E's on board 50pin LCD interface signal to the 44-pin (2x20 pin header) and 41pin (Hirose DF9-41P-1V) LCD connectors. The 44-pin or 41-pin connector will only support 24-bit flat pane.

• J3 : 44-pin LCD Interface Connector

1	+12V	2	+12V
3	GND	4	GND
5	5V or 3.3V	6	5V or 3.3V
7	FPVVEE	8	GND
9	P0	10	P1
11	P2	12	P3
13	P4	14	P5
15	P6	16	P7
17	P8	18	P9
19	P10	20	P11
21	P12	22	P13
23	P14	24	P15
25	P16	26	P17
27	P18	28	P19
29	P20	30	P21
31	P22	32	P23
33	GND	34	GND
35	SHFCLK	36	FLM
37	M	38	LP
39	GND	40	ENABKL
41	N/C	42	N/C
43	FPVDD	44	5V or 3.3V

• **J1 : 41-pin LCD Interface Connector**

1	P20	2	GND
3	P16	4	5V or 3.3V
5	P21	6	P0
7	P17	8	P8
9	P22	10	P1
11	P18	12	P9
13	P23	14	P2
15	P19	16	P10
17	5V or 3.3V	18	P3
19	FLM	20	P11
21	M	22	P4
23	LP	24	P12
25	SHFCLK	26	P5
27	5V or 3.3V	28	P13
29	5V or 3.3V	30	P6
31	ENABKL	32	P14
33	FPVDD	34	P7
35	FPVEE	36	P15
37	GND	38	+12V
39	GND	40	+12V
41	N/C		

• **J2 : LCD Backlight Power Connector**

PIN NO.	DESCRIPTION
1	N/C
2	GND
3	3.3V or 5V
4	GND
5	FPVEE Inverter Enable

Appendix C. Support Panel List

	Brand	LCD model	Diagonal	Type	Pin
1	PVI	P64CV1 LQ10D321 LQ10D421	6.4"	TFT	44
2	HITACHI	LMG9211XUCC CLX-8102S-C3X	9.4"	D_STN	44
3	TOSHIBA	LTM10C209A LTM10C273A	10.4"	TFT	44
4	KYOCERA	KCB104VG2BA-A01	10.4"	D_STN	44
5	TOSHIBA	LTM12C275A	12.1"	TFT	44
6	NEC	NL6448AC33-13 NL8060AC26-04 NL8060BC31-09 LQ12S41	10.4"	TFT	44
7	IMES	M121-S0H	12.1"	TFT	44
8	SHARP	LQ150X1DG11 LQ15X01W LQ14X03E	15"	TFT	44
9	UNIPAC	UP61V01	6.1"	TFT	44
10	SHARP	LM64183P LM64P11	9.4"	MONO	44
11	HITACHI	SP14Q001	5.7"	MONO	44
12	SHARP	LQ10D41 LQ10D321 LQ10D421	10.4"	TFT	44
13	SHARP	LM64C35PX KCS072VG1MA-A00	10.4"	D_STN	44
14	TOSHIBA	LTM10C209A LTM10C273A	10.4"	TFT	34