

**JUKI3711PT/3712T**  
**Intel Tualatin, Celeron and**  
**Pentium® III, Celeron,**  
**With Ethernet, VGA/LCD**  
**Ver 1.x**

# Contents

Introduction .....	1
1.1 Specifications : .....	2
1.2 What You Have .....	3
Installation.....	4
2.1 JUKI3711PT/3712T Layout.....	5
2.2 LCD Panel Shift Clock/Panel VCC Select.....	7
2.3 Clear CMOS Setup .....	7
2.4 DiskOnChip™ Flash Disk Memory Address setting .....	8
Connection.....	9
3.1 Floppy Disk Drive Connector .....	9
3.2 PCI IDE Disk Drive Connector .....	10
3.3 Parallel Port.....	10
3.4 Serial Ports.....	11
3.5 Keyboard Connector .....	12
3.6 USB Port Connector.....	12
3.7 External Switch, Indicator and IrDA .....	13
3.8 Fan Connector .....	13
3.9 LAN RJ45 Connector .....	14
3.10 VGA Connector .....	14
3.11 ATX Power Connector .....	14

3.12	ATX Power Connector .....	15
3.13	IrDA Infrared Interface port .....	15
3.14	LCD Connector .....	16
<b>BIOS Setup.....</b>		<b>17</b>
4.1	Introduction .....	17
4.2	Starting Setup .....	17
4.3	Using Setup.....	18
4.4	Getting Help .....	18
4.5	Main Menu .....	19
	<u>Setup Items</u> .....	20
4.6	STANDARD CMOS SETUP.....	22
4.7	ADVANCED BIOS FEATURES .....	26
4.8	ADVANCED CHIPSET FEATURES .....	30
4.9	INTEGRATED PERIPHERALS.....	33
4.10	POWER MANAGEMENT SETUP.....	36
4.11	PNP/PCI CONFIGURATIONS .....	40
4.12	PC HEALTH STATUS.....	40
4.13	FREQUENCY/VOLTAGE CONTROL.....	40
4.14	DEFAULTS MENU.....	43
4.15	SUPERVISOR/USER PASSWORD SETTING.....	44
4.16	EXIT SELECTING.....	45

Appendix A. Watch-Dog Timer .....	46
Appendix B. E <sup>2</sup> Key™ Function .....	48
Appendix C. Address Mapping .....	49
IO Address Map .....	49
1st MB Memory Address Map.....	50
IRQ Mapping Table.....	50
DMA Channel Assignments.....	50
Appendix C. ATX Power Supply .....	51
Appendix D. How to used Wake Up Function.....	53

## Introduction

Welcome to the JUKI3711PT/3712T Intel Tualatin, Celeron and Pentium® III, Celeron Single Board Computer. The JUKI 3711PT/3712T board is a PCISA/ISA form factor board, which comes equipped with high performance Intel Tualatin, Celeron and Pentium® III, Celeron Processor and advanced high performance multi-mode I/O, designed for the system manufacturers, integrators, or VARs that want to provide all the performance, reliability, and quality at a reasonable price.

In addition, the JUKI3711PT/3712T provides C&T MI69K VGA chip. The VGA which provides up to 1280x1024 resolution.

An advanced high performance super south chip – VIA VT82C686B is used in the JUKI3711PT/3712T board. Both on-chip UARTs are compatible with the NS16C550. The parallel port and IDE interface are compatible with IBM PC/AT architecture's.

JUKI3711PT/3712T uses Intel 82559/Realtek 8100 Fast Ethernet Multifunction PCI Controller as LAN controller. The Intel 82559/Realtek 8100 is a fully integrated 10BASE-T/100BASE-TX LAN solution with high performance networking functions and low power features.

JUKI3711PT/3712T uses the advanced VIA Chipset, VT82C694T/VT82C686B.

---

## 1.1 Specifications :

- **CPU** : Intel Tualatin, Celeron  
Pentium® III, Celeron
- **FSB** : 66/100/133MHz
- **Bus** : PCISA Bus, compatible to Jump PISA Ver. 1.07(JUKI3711PT)  
: ISA Bus(JUKI3712T)
- **DMA channels** : 7
- **Interrupt levels** : 15
- **Chipset** : VIA VT82C694T/VT82C686B
- **RAM memory** : Single 168-pin DIMM sockets support SDRAM module. The max memory is up to 512MB.
- **Ultra ATA100 IDE Interface** : Two PCI Enhance IDE hard drives. The south bridge supports Ultra ATA100 IDE interface.
- **Floppy disk drive interface** : Single 2.88 MB, 1.44MB, 1.2MB, 720KB, or 360KB floppy disk drive.
- **Two high speed Serial ports** : NS16C550 compatible UARTs, with two RS232.
- **Bi-directional Parallel Port** : compatible with ECP and EPP
- **Hardware Monitoring** : VT82C686B to monitor power supply voltage and fan speed status.
- **IrDA port** : Support Serial Infrared(SIR) and Amplitude Shift Keyed IR(ASKIR) interface.
- **USB port** : Support two USB ports for future expansion. USB 1.1.
- **WatchDog Timer** : can be set by 1,2,3...255 seconds period. Your program use IO address hex 843 and 443 to control the watch-dog and generate a system reset.
- **E<sup>2</sup>Key Function** : Nonvolatile memory for data backup and security.

- **VGA Controller** : C&T Mini 69000 VGA controller, 2M memory. Screen Resolution : up to 1280x1024 in 8-bit Color. Supports CRT & LCD interface.
- **Intel 82559/Realtek 8100 Fast Ethernet LAN PCI Controller** : IEEE 802.3u Auto-Negotiation support for 10BASE-T/100BASE-TX standard. Fast back-to-back transmission support with minimum interframe spacing. Connected to your LAN through RJ45 connector.
- **DiskOnChip™ Flash Disk** : supports one 32-pin socket for DiskOnChip Flash Disk
- **Keyboard Connector**
- **Mouse** : PS/2 Mouse Port on-board.
- **Power Consumption** : +5V/7.0A, +12V/0.5A(PIII 1G, 256MB)
- **Operating Temperature** : 0° ~ 60° C ( CPU needs Cooler)

---

## 1.2 What You Have

In addition to this *User's Manual*, the JUKI3711PT/3712T package includes the following items:

- JUKI3711PT/3712T Intel Tualatin, Celeron, Pentium® III, Celeron Single Board Computer.
- RS-232 Cable + Printer Cable x 1
- FDD Cable x 1
- IDE HDD DMA66 Cable x1
- 6-pin Mini-Din to 6-pin Din Keyboard & PS2 Mouse Cable x 1
- CD-ROM Driver x1

If any of these items is missing or damaged, contact the dealer from whom you purchased the product. Save the shipping materials and carton in case you want to ship or store the product in the future.

# 2

## Installation

This chapter describes how to install the JUKI3711PT/3712T. At first, the layout of JUKI3711PT/3712T is shown, and the unpacking information that you should be careful is described. The jumpers and switches setting for the JUKI3711PT/3712T's configuration, such as CPU type selection, system clock setting, and watchdog timer, are also included.

## 2.1 JUKI3711PT's Layout

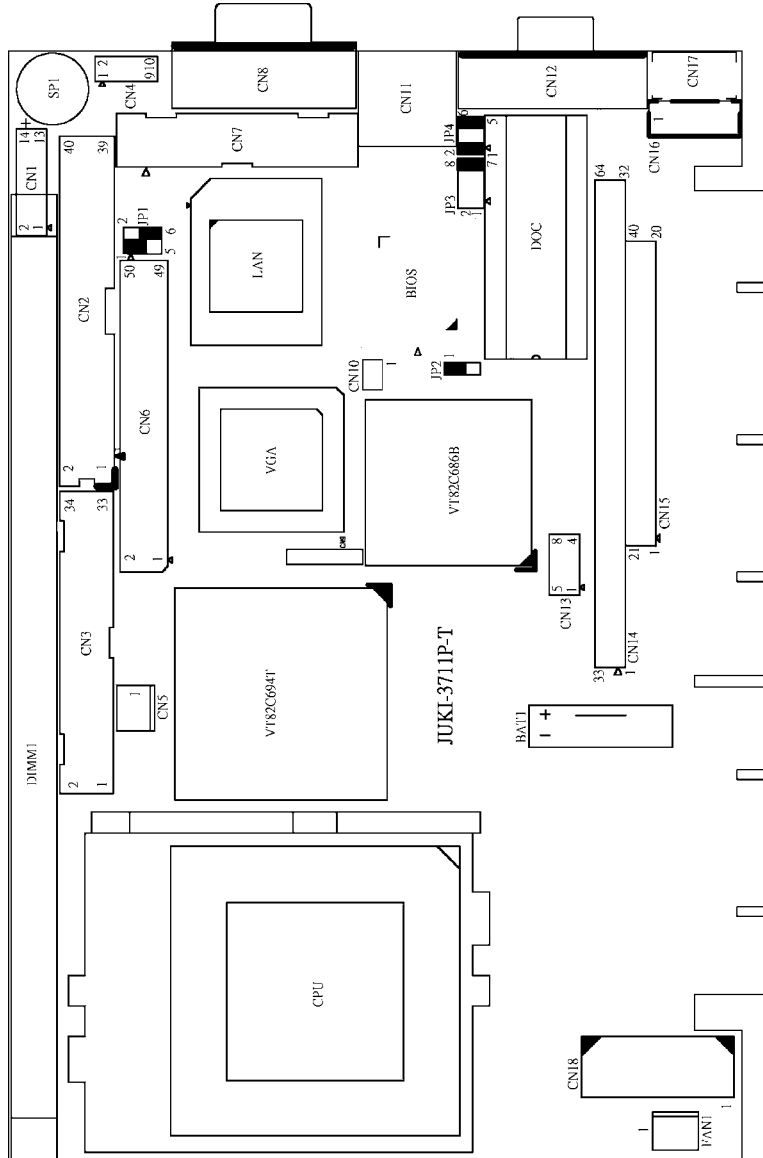

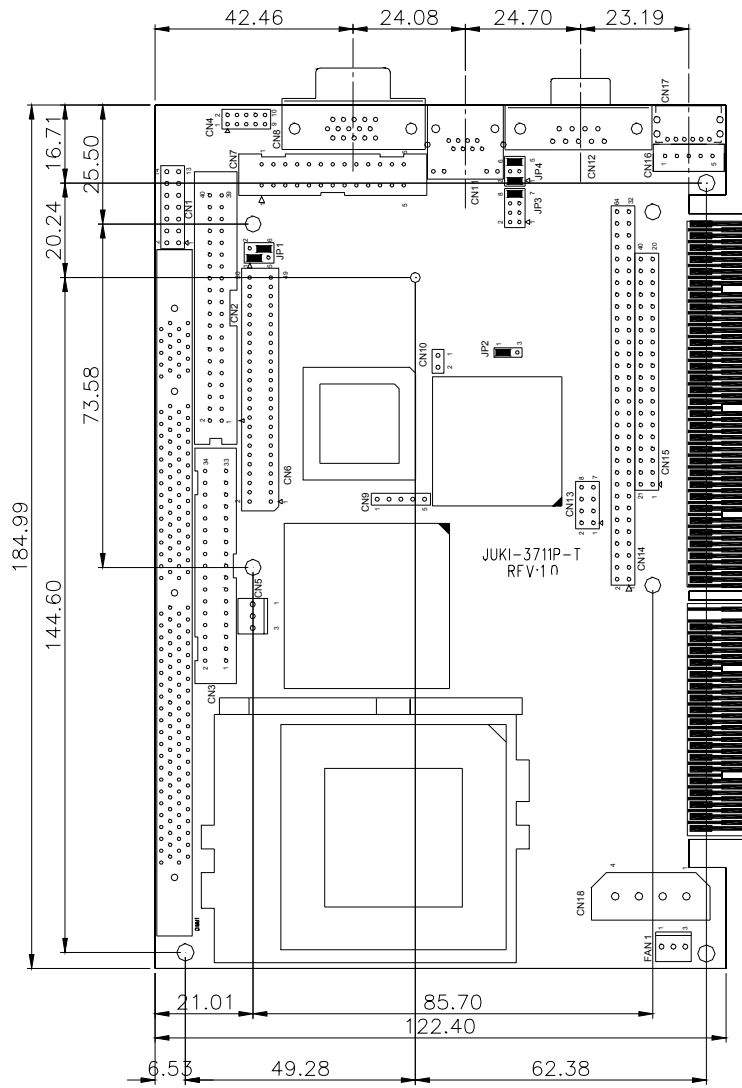

---

## 2.2 LCD Panel Shift Clock/Panel VCC Select

This jumper is for the setting of LCD panel shift clock mode and Panel power voltage.

- **JP1 : LCD Panel Shift Clock**

JP1	DESCRIPTION
1-3	Invert
3-5	Normal

- **JP1 : Panel VCC**

JP1	DESCRIPTION
2-4	+5V
4-6	+3.3

---

## 2.3 Clear CMOS Setup

If want to clear the CMOS Setup(for example forgot the password you should clear the setup and then set the password again.), you should close the JP2 about 3 seconds, then open again. Set back to normal operation mode.

- **JP2 : Clear CMOS Setup**

JP2	DESCRIPTION
1-2	Keep CMOS Setup (Normal Operation)
2-3	Clear CMOS Setup

---

## 2.4 DiskOnChip™ Flash Disk Memory Address setting

The DiskOnChip™ Flash Disk Chip (DOC) is produced by M-Systems. Because the DOC is 100% compatible to hard disk and DOS Customer don't need any extra software utility. It is just "plug and play", easy and reliable. **The MD-2200-Xmb series DOC will share only 8KB memory address.**

### • JP3 & JP4: DiskOnChip Memory Address Setting

ADDRESS	JP3				JP4		
	1-2	3-4	5-6	7-8	1-2	3-4	5-6
<b>CC000</b>	OPEN	OPEN	CLOSE	OPEN	OPEN	CLOSE	CLOSE
<b>CE000</b>	OPEN	OPEN	OPEN	CLOSE	OPEN	CLOSE	CLOSE
<b>D0000</b>	CLOSE	OPEN	OPEN	OPEN	CLOSE	OPEN	CLOSE
<b>D2000</b>	OPEN	CLOSE	OPEN	OPEN	CLOSE	OPEN	CLOSE
<b>D4000</b>	OPEN	OPEN	CLOSE	OPEN	CLOSE	OPEN	CLOSE
<b>D6000</b>	OPEN	OPEN	OPEN	CLOSE	CLOSE	OPEN	CLOSE
<b>D8000</b>	CLOSE	OPEN	OPEN	OPEN	OPEN	OPEN	CLOSE
<b>DA000</b>	OPEN	CLOSE	OPEN	OPEN	OPEN	OPEN	CLOSE
<b>DC000</b>	OPEN	OPEN	CLOSE	OPEN	OPEN	OPEN	CLOSE
<b>DE000</b>	OPEN	OPEN	OPEN	CLOSE	OPEN	OPEN	CLOSE

# 3

## Connection

This chapter describes how to connect peripherals, switches and indicators to the JUKI3711PT/3712T board.

---

### 3.1 Floppy Disk Drive Connector

JUKI3711PT/3712T board equipped with a 34-pin daisy-chain driver connector cable.

#### • CN3 : FDC CONNECTOR

PIN NO.	DESCRIPTION	PIN NO.	DESCRIPTION
1	GROUND	2	REDUCE WRITE
3	GROUND	4	N/C
5	GROUND	6	N/C
7	GROUND	8	INDEX#
9	GROUND	10	MOTOR ENABLE A#
11	GROUND	12	DRIVE SELECT B#
13	GROUND	14	DRIVE SELECT A#
15	GROUND	16	MOTOR ENABLE B#
17	GROUND	18	DIRECTION#
19	GROUND	20	STEP#
21	GROUND	22	WRITE DATA#
23	GROUND	24	WRITE GATE#
25	GROUND	26	TRACK 0#
27	GROUND	28	WRITE PROTECT#
29	GROUND	30	READ DATA#
31	GROUND	32	SIDE 1 SELECT#
33	GROUND	34	DISK CHANGE#

---

### 3.2 PCI IDE Disk Drive Connector

You can attach two IDE( Integrated Device Electronics) hard disk drives to the JUKI3711P/3712 IDE controller. This connector supports ATA-66 hard disk ribbon cable.

#### • CN2 : IDE Interface Connector

PIN NO.	DESCRIPTION	PIN NO.	DESCRIPTION
1	RESET#	2	GROUND
3	DATA 7	4	DATA 8
5	DATA 6	6	DATA 9
7	DATA 5	8	DATA 10
9	DATA 4	10	DATA 11
11	DATA 3	12	DATA 12
13	DATA 2	14	DATA 13
15	DATA 1	16	DATA 14
17	DATA 0	18	DATA 15
19	GROUND	20	N/C
21	IDE DREQ	22	GROUND
23	IOW#	24	GROUND
25	IOR#	26	GROUND
27	IDE DRDYA	28	GROUND
29	IDE DACK	30	GROUND
31	INTERRUPT	32	N/C
33	SA1	34	CABLE_80P
35	SA0	36	SA2
37	HDC CS0#	38	HDC CS1#
39	HDD ACTIVE#	40	GROUND

---

### 3.3 Parallel Port

This port is usually connected to a printer. The JUKI 3711PT/3712T includes an on-board parallel port, accessed through a 26-pin flat-cable to connector CN7

• **CN7 : Parallel Port Connector**

PIN NO.	DESCRIPTION	PIN NO.	DESCRIPTION
1	STROBE#	14	AUTO FORM FEED #
2	DATA 0	15	ERROR#
3	DATA 1	16	INITIALIZE
4	DATA 2	17	PRINTER SELECT LN#
5	DATA 3	18	GROUND
6	DATA 4	19	GROUND
7	DATA 5	20	GROUND
8	DATA 6	21	GROUND
9	DATA 7	22	GROUND
10	ACKNOWLEDGE	23	GROUND
11	BUSY	24	GROUND
12	PAPER EMPTY	25	GROUND
13	PRINTER SELECT	26	NC

---

**3.4 Serial Ports**

The JUKI3711PT/3712T offers two high speed NS16C550 compatible UARTs with Read/Receive 16 byte FIFO.

- **CN12** : COM1 (external DB-9 connector)
- **CN4** : COM2

CN12	CN4	DESCRIPTION
1	1	DATA CARRIER DETECT
2	3	RECEIVE DATA
3	5	TRANSMIT DATA
4	7	DATA TERMINAL READY
5	9	GROUND
6	2	DATA SET READY
7	4	REQUEST TO SEND
8	6	CLEAR TO SEND
9	8	RING INDICATOR
	10	N/C

---

### 3.5 Keyboard Connector

The JUKI3711PT/3712T provides 6-pin Min-DIN Keyboard /mouse connector.

- **CN17 : 6-pin Mini-DIN Keyboard/Mouse Connector**

PIN NO.	DESCRIPTION
1	KEYBOARD DATA
2	MOUSE DATA
3	GROUND
4	+5V
5	KEYBOARD CLOCK
6	MOUSE CLOCK

- **CN16 : 5-pin External Keyboard Connector**

PIN NO.	DESCRIPTION
1	KEYBOARD CLOCK
2	KEYBOARD DATA
3	NC
4	GROUND
5	+5V

---

### 3.6 USB Port Connector

The JUKI3711PT/3712T built-in two USB ports for the future new I/O bus expansion. It complies with USB 1.1.

- **CN13 : USB 0,1**

PIN NO.	DESCRIPTION	PIN NO.	DESCRIPTION
1	VCC	5	GROUND
2	DATA-	6	DATA +
3	DATA+	7	DATA -
4	GROUND	8	VCC

---

### 3.7 External Switch, Indicator

There are several external switches and indicators for monitoring and controlling your CPU board. All the functions are in the CN1 connector.

- **CN1: Pin Assignment and Functions**

FUNCTION	PIN NO.	DESCRIPTION
SPEAKER	2	SPK SIGNAL
	4	N/C
	6	N/C
	8	VCC
RESET	10	POWER RESET
	12	GROUND
HDD LED	13	VCC
	14	LED
POWER LED	1	VCC
	3	N/C
	5	GROUND
NO FUNCTION	7	N/C
	9	GROUND
	11	GROUND

---

### 3.8 Fan Connector

The JUKI3711PT/3712P provides CPU cooling fan connector, chassis fan connector. These connectors can supply 12V/500mA to the cooling fan. In the connector there have a "rotation" pin. The rotation pin is to get the fan's rotation signal to system. So the system BIOS could recognize the fan speed. Please note only specified fan offers the rotation signal.

- **FAN1 : CPU Fan Connector**

PIN NO.	DESCRIPTION
1	Ground
2	12V
3	Rotation Signal

---

### 3.9 LAN RJ45 Connector

JUKI3711PT/3712T is equipped with a built-in 10/100Mbps Ethernet Controller. You can connect it to your LAN through RJ45 LAN connector. The pin assignments are as following:

• **CN11 : LAN RJ45 Connector**

PIN NO.	DESCRIPTION	PIN NO.	DESCRIPTION
1	TX+	5	N/C
2	TX-	6	RX-
3	RX+	7	N/C
4	N/C	8	N/C

---

### 3.10 VGA Connector

The pin assignments are as following.

• **CN8 : 15-pin Connector**

PIN NO.	DESCRIPTION	PIN NO.	DESCRIPTION
1	RED	2	GREEN
3	BLUE	4	N/C
5	GROUND	6	GROUND
7	GROUND	8	GROUND
9	VCC	10	GROUND
11	N/C	12	DDC DAT
13	HSYNC	14	VSYNC
15	DDCCLK		

---

### 3.11 ATX Power Connector

The pin assignments are as following

**CN5 : ATX Power Connector**

PIN NO.	DESCRIPTION
1	5VSB
2	PS_ON
3	GROUND

**CN10 : ATX Power SW**

PIN NO.	DESCRIPTION
1	Power SW
2	GROUND

---

**3.12 Power Connector**

The pin assignments are as following

**CN18 : Power Connector**

PIN NO.	DESCRIPTION
1	+12V
2	GROUND
3	GROUND
4	+5V

---

**3.13 IrDA Infrared Interface Port**

The JUKI3711PT/3712T built-in an IrDA port which support Serial Infrared (SIR) or Amplitude Shift Keyed IR (ASKIR) interface. When use the IrDA port have to set SIR or ASKIR model in the BIOS's Peripheral Setup's COM2. Then the normal RS-232 COM2 will be disabled.

**• CN9: IrDA connector**

PIN NO.	DESCRIPTION
1	VCC
2	N/C
3	IRRX
4	GROUND
5	IR-TX

---

### 3.14 LCD Connector

JUKI3711PT/3712T board equipped with a 50-pin connector.

#### • CN6 : LCD CONNECTOR

PIN NO.	DESCRIPTION	PIN NO.	DESCRIPTION
1	VCLK	2	P33
3	P34	4	P31
5	P35	6	P32
7	P30	8	P28
9	P29	10	P27
11	P25	12	P26
13	P24	14	P21
15	P23	16	P22
17	P16	18	P20
19	P17	20	P18
21	P19	22	P14
23	P13	24	P12
25	P15	26	P11
27	P7	28	P10
29	Panel-VCC	30	Panel-VCC
31	P9	32	P8
33	P4	34	P6
35	P3	36	P5
37	P2	38	P1
39	M	40	P0
41	Shift Clock	42	Enable Backlight
43	FPVDD	44	FLM
45	Enable VEE	46	LP
47	GND	48	GND
49	Inverter VCC	50	Inverter VCC

# 4

## BIOS Setup

---

### **4.1 Introduction**

This chapter discusses Award™ Setup program built into the ROM BIOS. The Setup program allows users to modify the basic system configuration. This special information is then stored in battery-backed CMOS RAM so that it retains the Setup information while the power is off.

---

### **4.2 Starting Setup**

The BIOS is immediately activated when you turn on the computer. While the BIOS is in control, the Setup program can be activated in one of two ways:

1. By pressing <Del> immediately after switching the system on, or
2. by pressing the <Del> key when the following message appears briefly at the bottom of the screen during the POST (Power On Self-Test).

Press DEL to enter SETUP.

If the message disappears before you respond and you still wish to enter Setup, restart the system to try again by turning it OFF then ON or pressing the "RESET" button on the system case. You may also restart by simultaneously pressing <Ctrl>, <Alt>, and <Delete> keys. If you do not press the keys at the correct time and the system does not boot, an error message will be displayed and you will again be asked to...

PRESS F1 TO CONTINUE, DEL TO ENTER SETUP

---

### 4.3 Using Setup

In general, you use the arrow keys to highlight items, press <Enter> to select, use the PageUp and PageDown keys to change entries, press <F1> for help and press <Esc> to quit. The following table provides more detail about how to navigate in the Setup program using the keyboard.

Key	Function
Up Arrow	Move to the previous item
Down Arrow	Move to the next item
Left Arrow	Move to the item on the left (menu bar)
Right Arrow	Move to the item on the right (menu bar)
Esc	Main Menu: Quit without saving changes Submenus: Exit Current page to the next higher level menu
Move Enter	Move to the item you desired
PgUp key	Increase the numeric value or make changes
PgDn key	Decrease the numeric value or make changes
+ key	Increase the numeric value or make changes
- key	Decrease the numeric value or make changes
Esc key	Main Menu -- Quit and not save changes into CMOS Status Page Setup Menu and Option Page Setup Menu - - Exit current page and return to Main Menu
F1 key	General help on Setup navigation keys
F5 key	Load previous values from CMOS
F6 key	Load the fail-safe defaults from BIOS default table
F7 key	Load the optimized defaults
F10 key	Save all the CMOS changes and exit



Note that a brief description of each highlighted selection appears at the bottom of the screen.

### **Setup Items**

The main menu includes the following main setup categories.

---

#### ***STANDARD CMOS FEATURES***

Use this menu for basic system configuration. See Section 4.6 for the details.

---

#### ***ADVANCED BIOS FEATURES***

Use this menu to set the Advanced Features available on your system. See Section 4.7 for the details.

---

#### ***ADVANCED CHIPSET FEATURES***

Use this menu to change the values in the chipset registers and optimize your system's performance. See section 4.8 for the details.

---

#### ***INTEGRATED PERIPHERALS***

Use this menu to specify your settings for integrated peripherals. See section 4.9 for the details.

---

#### ***POWER MANAGEMENT SETUP***

Use this menu to specify your settings for power management. See section 4.10 for the details.

---

#### ***PNP / PCI CONFIGURATION***

This entry appears if your system supports PnP / PCI. See section 4.11 for the details.

---

#### ***PC HEALTH STATUS***

Use this menu to monitor your hardware. See section 4.12 for the details.

---

#### ***FREQUENCY/VOLTAGE CONTROL***

Use this menu to specify your settings for frequency/voltage control. See section 4.13 for the details.

---

**LOAD FAIL-SAFE DEFAULTS**

Use this menu to load the BIOS default values for the minimal/stable performance for your system to operate. See section 4.14 for the details.

---

**LOAD OPTIMIZED DEFAULTS**

Use this menu to load the BIOS default values that are factory settings for optimal performance system operations. While Award has designed the custom BIOS to maximize performance, the factory has the right to change these defaults to meet their needs. See section 4.14 for the details.

---

**SUPERVISOR / USER PASSWORD**

Use this menu to set User and Supervisor Passwords. See section 4.15 for the details.

---

**SAVE & EXIT SETUP**

Save CMOS value changes to CMOS and exit setup. See section 10 for the details.

---

**EXIT WITHOUT SAVE**

Abandon all CMOS value changes and exit setup. See section 10 for the details.

#### 4.6 STANDARD CMOS SETUP

The items in Standard CMOS Setup Menu are divided into 10 categories. Each category includes no, one or more than one setup items. Use the arrow keys to highlight the item and then use the <PgUp> or <PgDn> keys to select the value you want in each item.

CMOS Setup Utility - Copyright ( C ) 1984-2001 Award Software  
Standard CMOS Features

Date:	Mon, Jan 21 2002	Item Help
Time:	16 : 19 : 20	
➤ IDE Primary Master	[ 2557 MB ]	Menu Level ➤  Change the day, month, year and century
➤ IDE Primary Slave	[ None ]	
Drive A	[ 1.44M, 3.5 in.]	
Drive B	[ None ]	
LCD&CRT	[ Both ]	
Panel Type	[ 640x480 18-TFT ]	
Halt On	[ All , But Keyboard ]	
Based Memory	640K	
Extended Memory	64512K	
Total Memory	65536K	
↑↓←→Move Enter: Select +/-/PU/PD: Value F10:Save ESC: Exit F1:General Help F5:Previous Values F6:Fail-safe defaults F7:Optimized Defaults		

## Standard CMOS Setup Selections

Item	Options	Description
Date	MM DD YYYY	Set the system date.
Time	HH : MM : SS	Set the system time
IDE Primary Master	Options are in its sub menu (described in Table 3)	Press <Enter> to enter the sub menu of detailed options
IDE Primary Slave	Options are in its sub menu (described in Table 3)	Press <Enter> to enter the sub menu of detailed options
Drive A Drive B	None 360K, 5.25 in 1.2M, 5.25 in 720K, 3.5 in 1.44M, 3.5 in 2.88M, 3.5 in	Select the type of floppy disk drive installed in your system
LCD & CRT	Both LCD CRT	Select the default display device
LCD TYPE	1024x768 DSTN 640x480 MONO 640x480 DSTN 800x600 DSTN 640x480 12-TFT 640x480 18-TFT 1024x768 36-TFT 800x600 TFT 1024x768 18-TFT 1024x768 24-TFT	Select the default LCD display Type
Halt On	All Errors No Errors All, but Keyboard All, but Diskette All, but Disk/Key	Select the situation in which you want the BIOS to stop the POST process and notify you

## IDE Adapters

The IDE adapters control the hard disk drive. Use a separate sub menu to configure each hard disk drive.

Figure 2 shows the IDE primary master sub menu.

CMOS Setup Utility - Copyright ( C ) 1984-2001 Award Software

IDE Primary Master

IDE HDD Auto-Detection	Press Enter	Item Help
IDE Primary Master	Auto 2557 MB	Menu Level >>  To auto-detect the HDD's size, head... on this channel
Access Mode	Auto	
Cylinder	4956	
Head	16	
Precomp	0	
Landing Zone	4955	
Sector	63	
↑↓←→Move Enter: Select +/-PU/PD: Value F10:Save ESC: Exit F1:General Help F5:Previous Values F6:Fail-safe defaults F7:Optimized Defaults		

Use the legend keys to navigate through this menu and exit to the main menu. Use Table 3 to configure the hard disk.

Item	Options	Description
IDE HDD Auto-detection	Press Enter	Press Enter to auto-detect the HDD on this channel. If detection is successful, it fills the remaining fields on this menu.
IDE Primary Master	None Auto Manual	Selecting 'manual' lets you set the remaining fields on this screen. Selects the type of fixed disk. "User Type" will let you select the number of cylinders, heads, etc. Note: PRECOMP=65535 means NONE !
Capacity	Auto    Display your disk drive size	Disk drive capacity (Approximated). Note that this size is usually slightly greater than the size of a formatted disk given by a disk checking program.
Access Mode	Normal LBA Large Auto	Choose the access mode for this hard disk
The following options are selectable only if the 'IDE Primary Master' item is set to 'Manual'		
Cylinder	Min = 0 Max = 65535	Set the number of cylinders for this hard disk.
Head	Min = 0 Max = 255	Set the number of read/write heads
Precomp	Min = 0 Max = 65535	**** <b>Warning:</b> Setting a value of 65535 means no hard disk
Landing zone	Min = 0 Max = 65535	****
Sector	Min = 0 Max = 255	Number of sectors per track

## 4.7 ADVANCED BIOS FEATURES

This section allows you to configure your system for basic operation. You have the opportunity to select the system's default speed, boot-up sequence, keyboard operation, shadowing and security.

CMOS Setup Utility - Copyright ( C ) 1984-2001 Award Software

### Advanced BIOS Features

Virus Warning	Disabled	Item Help
CPU Internal Cache	Enabled	
External Cache	Enabled	
CPU L2 Cache ECC Checking	Enabled	Menu Level ➤
Quick Power On Self Test	Enabled	Allows you to choose the VIRUS
Onboard Lan Boot ROM	Disabled	warning feature for IDE Hard Disk
First Boot device	Floppy	boot sector protection. If this
Second Boot device	HDD-0	function is enabled and someone
Third Boot device	LS120	attempt to write data into this area,
Boot other device	Enabled	BIOS will show a warning message
Swap Floppy Drive	Disabled	on screen and alarm beep
Boot Up Floppy Seek	Enabled	
Boot Up NumLock Status	On	
Gate A20 Option	Fast	
Typematic Rate Setting	Disabled	
Typematic Rate (Chars/Sec)	6	
Typematic Delay (Msec)	250	
Security Option	Setup	
OS Select For DRAM > 64MB	Non-OS2	
Video Bios Shadow	Enabled	
C8000-CBFFF shadow	Disabled	
CC000-CFFFF shadow	Disabled	
D0000-D3FFF shadow	Disabled	
D4000-D7FFF shadow	Disabled	
D8000-DBFFF shadow	Disabled	
DC000-DFFFF shadow	Disabled	
Small Logo(EPA) show	Disabled	
↑↓←→Move Enter: Select +/-/PU/PD: Value F10:Save ESC: Exit F1:General Help F5:Previous Values F6:Fail-safe defaults F7:Optimized Defaults		

### ***Virus Warning***

Allows you to choose the VIRUS Warning feature for IDE Hard Disk boot sector protection. If this function is enabled and someone attempt to write data into this area, BIOS will show a warning message on screen and alarm beep.

Enabled	Activates automatically when the system boots up causing a warning message to appear when anything attempts to access the boot sector or hard disk partition table.
Disabled	No warning message will appear when anything attempts to access the boot sector or hard disk partition table.

---

**CPU Internal Cache/External Cache**

These two categories speed up memory access. However, it depends on CPU/chipset design.

Enabled	Enable cache
Disabled	Disable cache

---

**CPU L2 Cache ECC Checking**

This item allows you to enable/disable CPU L2 Cache ECC checking. The choice: Enabled, Disabled.

---

**Quick Power On Self Test**

This category speeds up Power On Self Test (POST) after you power up the computer. If it is set to Enable, BIOS will shorten or skip some check items during POST.

Enabled	Enable quick POST
Disabled	Normal POST

---

**Onboard Lan Boot ROM**

This item allows you to enable/disable Onboard Lan Boot ROM. The choice: Enabled, Disabled.

---

**First/Second/Third Boot other Device**

The BIOS attempts to load the operating system from the devices in the sequence selected in these items.

The Choice: Floppy, LS/ZIP, HDD, SCSI, CDROM, Disabled.

---

**Swap Floppy Drive**

If the system has two floppy drives, you can swap the logical drive name assignments.

The choice: Enabled/Disabled.

---

**Boot Up Floppy Seek**

Seeks disk drives during boot up. Disabling speeds boot up.

The choice: Enabled/Disabled.

---

**Boot Up Numlock Status**

Select power on state for NumLock.

The choice: On/Off.

---

**Gate A20 Option**

Select if chipset or keyboard controller should control GateA20.

Normal	A pin in the keyboard controller controls GateA20
Fast	Lets chipset control GateA20

---

**Typematic Rate Setting**

Key strokes repeat at a rate determined by the keyboard controller. When enabled, the typematic rate and typematic delay can be selected.

The choice: Enabled/Disabled.

---

**Typematic Rate (Chars/Sec)**

Sets the number of times a second to repeat a key stroke when you hold the key down.

The choice: 6, 8, 10, 12, 15, 20, 24, 30.

---

**Typematic Delay (Msec)**

Sets the delay time after the key is held down before it begins to repeat the keystroke.

The choice: 250, 500, 750, 1000.

---

**Security Option**

Select whether the password is required every time the system boots or only when you enter setup.

---

System	The system will not boot and access to Setup will be denied if the correct password is not entered at the prompt.
Setup	The system will boot, but access to Setup will be denied if the correct password is not entered at the prompt.

Note: To disable security, select PASSWORD SETTING at Main Menu and then you will be asked to enter password. Do not type anything and just press <Enter>, it will disable security. Once the security is disabled, the system will boot and you can enter Setup freely.

---

**OS Select For DRAM > 64MB**

Select the operating system that is running with greater than 64MB of RAM on the system.

The choice: Non-OS2, OS2.

---

**Video BIOS Shadow**

This item allows the video BIOS to be copied to system memory for faster performance.

The Choice : Enable , Disable.

---

**C8000-CBFFF Shadow / DC000-DFFFF Shadow**

These categories determine whether option ROMs will be copied to RAM. An example of such option ROM would be support of on-board SCSI.

Enabled	Optional shadow is enabled
Disabled	Optional shadow is disabled

---

**Small Logo(EPA) Show**

This item allows you to enable/disable Small Logo(EPA) Show.

The choice: Enabled, Disabled.

---

## 4.8 ADVANCED CHIPSET FEATURES

CMOS Setup Utility - Copyright ( C ) 1984-2001 Award Software

### Advanced Chipset Features

DRAM Timing By SPD	Enabled	Item Help
DRAM Clock	Host CLK	
SDRAM Cycle Length	3	
Memory Hole	Disabled	Menu Level >
P2C/C2P Concurrency	Disabled	
System BIOS Cacheable	Disabled	
Video BIOS Cacheable	Disabled	
OnChip USB	Disabled	
USB Keyboard Support	Disabled	
USB Mouse Support	Disabled	
OnChip Sound	AUTO	
CPU to PCI Write Buffer	Enabled	
PCI Dynamic Bursting	Enabled	
PCI Master 0 WS Write	Enabled	
PCI Delay Transaction	Enabled	
PCI#2 Access #1 Retyr	Enabled	
Memory Parity/ECC check	Disabled	

↑↓←→Move Enter: Select +/-/PU/PD: Value F10:Save ESC: Exit F1:General Help  
F5:Previous Values F6:Fail-safe defaults F7:Optimized Defaults

This section allows you to configure the system based on the specific features of the installed chipset. This chipset manages bus speeds and access to system memory resources, such as DRAM and the external cache. It also coordinates communications between the conventional ISA bus and the PCI bus. It must be stated that these items should never need to be altered. The default settings have been chosen because they provide the best operating conditions for your system.

---

### **DRAM Timing By SPD**

This item allows you to select the value in this field, depending on whether the board has paged DRAMs or EDO (extended data output) DRAMs.

The Choice: Enabled, Disabled.

---

### **DRAM Clock**

This item allows you to control the DRAM speed.

The Choice: Host CLK, HCLK-33M, HCLK+33M.

---

**SDRAM Cycle Length**

Select the number of SCLKs for an access cycle.

The Choice: 2, 3.

---

**DRAM Clock**

Selecting HOST Clk is DRAM Clock equal CPU HOST Clock. If you choice HOST-33, DRAM Clock equal CPU Host Clock-33MHz.

The Choice: HOST Clk, HOST-33.

---

**Memory Hole**

You can reserve this area of system memory for ISA adapter ROM. When this area is reserved, it cannot be cached. The user information of peripherals that need to use this area of system memory usually discusses their memory requirements.

The Choice: 15M-16M, Disabled

---

**P2c/C2P Concurrency**

This item allows you to enable/disable the PCI to CPU, CPU to PCI concurrency.

The choice: Enabled, Disabled.

---

**System BIOS Cacheable**

Selecting Enabled allows caching of the system BIOS ROM at F0000h-FFFFFh, resulting in better system performance. However, if any program writes to this memory area, a system error may result.

The choice: Enabled, Disabled.

---

**Video BIOS Cacheable**

Select Enabled allows caching of the video BIOS , resulting in better system performance. However, if any program writes to this memory area, a system error may result.

The Choice: Enabled, Disabled.

---

**OnChip USB**

Select *Enabled* if your system contains a Universal Serial Bus (USB) controller and you have USB peripherals.

The choice: Enabled, Disabled.

---

---

**USB Keyboard Support**

Select *Enabled* if your system contains a Universal Serial Bus (USB) controller and you have a USB keyboard.  
The choice: Enabled, Disabled.

---

**USB Mouse Support**

Select *Enabled* if your system contains a Universal Serial Bus (USB) controller and you have a USB Mouse.  
The choice: Enabled, Disabled.

---

**CPU to PCI Write Buffer**

This item allows you to enable/disable the CPU to PCI Write Buffer .  
The Choice: Enabled, Disabled.

---

**PCI Dynamic Bursting**

When *Enabled*, every write transaction goes to the write buffer. Burstable transactions then burst on the PCI bus and nonburstable transactions don't.  
The Choice: Enabled, Disabled.

---

**PCI Master 0 WS Write**

When *Enabled*, writes to the PCI bus are executed with zero wait states.  
The Choice: Enabled, Disabled.

---

**PCI Delay Transaction**

This item allows you to enable/disable the PCI Delay Transaction.  
The Choice: Enabled, Disabled.

---

**PCI#2 Access #1 Retyr**

This item allows you to enable/disable the PCI#2 Access #1 Retyr.  
The Choice: Enabled, Disabled.

---

**Memory Parity/ECC check**

This item allows you to enable/disable the Memory Parity/ECC check.  
The Choice: Enabled, Disabled.

---

## 4.9 INTEGRATED PERIPHERALS

CMOS Setup Utility – Copyright © 1984 – 2001 Award Software

### Integrated Peripherals

		Item Help
OnChip IDE Channel0	[Enabled]	
IDE Prefetch Mode	[Enabled]	
Primary Master PIO	[Auto]	Menu Level >
Primary Slave PIO	[Auto]	
Primary Master UDMA	[Auto]	
Primary Slave UDMA	[Auto]	
Init Display First	[PCI Slot]	
Onboard VGA Device	[Enabled]	
Onboard Lan Device	[Enabled]	
IDE HDD Block Mode	[Enabled]	If your IDE hard drive supports block mode select Enabled for automatic detection of the optimal number of block read/write per sector the drive can support
Onboard FDC Controller	[Enabled]	
Onboard Serial Port 1	[Auto]	
Onboard Serial Port 2	[Auto]	
UART 2 Mode	[Standard]	
IR Function Duplex	[Normal]	
TX,RX inverting enable	[No, Yes]	
Onboard Parallel Port	[378/IRQ7]	
Onboard Parallel Mode	[Normal]	
ECP Mode Use DMA	[3]	
Parallel Port EPP Type	[EPP1.9]	

↑↓←→ Move Enter: Select +/-/PU/PD: Value F10:Save ESC: Exit F1:General Help  
F5:Previous Values F6:Fail-safe defaults F7:Optimized Defaults

---

### **OnChip IDE Channel 0**

The integrated peripheral controller contains an IDE interface with support for two IDE channels. Select *Enabled* to activate each channel separately.

The choice: Enabled, Disabled.

---

### **IDE Prefetch Mode**

The onboard IDE drive interfaces supports IDE prefetching for faster drive accesses. If you install a primary and/or secondary add-in IDE interface, set this field to *Disabled* if the interface does not support prefetching.

The choice: Enabled, Disabled.

---

### **IDE Primary Master/Slave PIO**

The two IDE PIO (Programmed Input/Output) fields let you set a PIO mode (0-4) for each of the two IDE devices that the onboard IDE interface supports. Modes 0 through 4 provide successively increased performance. In Auto mode, the system automatically determines the best mode for each device.

The choice: Auto, Mode 0, Mode 1, Mode 2, Mode 3, Mode 4.

---

#### ***IDE Primary/Secondary Master/Slave UDMA***

Ultra DMA/33/66 implementation is possible only if your IDE hard drive supports it and the operating environment includes a DMA driver (Windows 95 OSR2 or a third-party IDE bus master driver). If your hard drive and your system software both support Ultra DMA/33/66, select Auto to enable BIOS support.

The Choice: Auto, Disabled.

---

#### ***Init Display First***

This item allows you to decide to active whether PCI Slot or on-chip VGA first

The choice: PCI Slot, Onboard , AGP

---

#### ***Onboard VGA Device***

This item allows you to enable/disable the Onboard VGA Device.

The Choice: Enabled, Disabled.

---

#### ***Onboard Lan Device***

This item allows you to enable/disable the Onboard Lan Device.

The Choice: Enabled, Disabled.

---

#### ***IDE HDD Block Mode***

Block mode is also called block transfer, multiple commands, or multiple sector read/write. If your IDE hard drive supports block mode (most new drives do), select Enabled for automatic detection of the optimal number of block read/writes per sector the drive can support.

The choice: Enabled, Disabled

---

#### ***Onboard FDC Controller***

Select Enabled if your system has a floppy disk controller (FDC) installed on the system board and you wish to use it. If you install and-in FDC or the system has no floppy drive, select Disabled in this field.  
The choice: Enabled, Disabled.

---

***Onboard Serial Port 1/Port 2***

Select an address and corresponding interrupt for the first and second serial ports.  
The choice: 3F8/IRQ4, 2E8/IRQ3, 3E8/IRQ4, 2F8/IRQ3, Disabled, Auto.

---

***UART 2 Mode***

This item allows you to select which mode for the Onboard Serial Port 2.  
The choice: Standard, HPSIR, ASKIR.

---

***IR Function Duplex***

This item allows you to select the IR half/full duplex function.  
The choice: Half, Full.

---

***TX ,RX inverting enable***

This item allow you to enable the TX, RX inverting which depends on different H/W requirement. This field is not recommended to change its default setting for avoiding any error in your system  
The choice: No, No/ No, Yes(Default)/ Yes, No/ Yes, Yes.

---

***Onboard Parallel Port***

Select an address and corresponding interrupt for the parallel port.  
The Choice: 3BC/IRQ7, 378/IRQ7, 278/IRQ5, Disabled.

---

***Onboaed Parallel Mode***

Select parallel port Mode.  
The Choice: SPP, EPP, ECP, ECP+EPP.

---

***ECP Mode Use DMA***

Select a ECP mode used DMA channel.  
The choice: 1, 3.

---

***Parallel Port EPP Type***

Select a EPP mode.  
The choice: EPP1.7, EPP1.9.

---

---

## 4.10 POWER MANAGEMENT SETUP

The Power Management Setup allows you to configure your system to most effectively save energy while operating in a manner consistent with your own style of computer use.

CMOS Setup Utility – Copyright © 1984 – 2001 Award Software

### Power Management Setup

ACPI function	[Disabled]	Item Help
> Power Management	[Press Enter]	
PM Control by APM	[Yes]	Menu Level >
Video Off Option	[Suspend -> Off]	
Video Off Method	[V/H SYNC+Blank]	
MODEM Use IRQ	[3]	
Soft-Off by PWRBTN	[Instant-Off]	
State After Power Failure	[Auto]	
> Wake Up Events	[Press Enter]	
↑↓←→Move Enter: Select +/-/PU/PD: Value F10:Save ESC: Exit F1:General Help F5:Previous Values F6:Fail-safe defaults F7:Optimized Defaults		

The Power Management Setup allows you to configure your system to most effectively save energy while operating in a manner consistent with your own style of computer use.

---

### ACPI Function

This item allows you to enable/disable the Advanced Configuration and Power Management (ACPI).

The choice: Enabled, Disabled.

---

### POWER MANAGEMENT

This category allows you to select the type (or degree) of power saving and is directly related to the following modes:

1. **HDD Power Down** : When enabled and after the set time of system inactivity, the hard disk drive will be powered down while all other devices remain active.
2. **Doze Mode**: When enabled and after the set time of system inactivity, the CPU clock will run at slower speed while all other devices still operate at full speed.
3. **Suspend Mode**: When enabled and after the set time of system inactivity, all devices except the CPU will be shut off.

There are four selections for Power Management, three of which have fixed mode settings.

Disable (default)	No power management. Disables all four modes
Min. Power Saving	Minimum power management. Doze Mode = 1 hr. Standby Mode = 1 hr., Suspend Mode = 1 hr., and HDD Power Down = 15 min.
Max. Power Saving	Maximum power management -- <b>ONLY AVAILABLE FOR SL CPU's</b> . Doze Mode = 1 min., Standby Mode = 1 min., Suspend Mode = 1 min., and HDD Power Down = 1 min.
User Defined	Allows you to set each mode individually. When not disabled, each of the ranges are from 1 min. to 1 hr. except for HDD Power Down which ranges from 1 min. to 15 min. and disable.

---

**PM Control by APM**

When enabled, an Advanced Power Management device will be activated to enhance the Max. Power Saving mode and stop the CPU internal clock. If Advance Power Management (APM) is installed on your system, selecting Yes gives better power savings.

If the Max. Power Saving is not enabled, this will be preset to *No*.

The choice: Yes, No.

---

**Video Off Option**

When enabled, this feature allows the VGA adapter to operate in a power saving mode.

Always On	Monitor will remain on during power saving modes.
Suspend --> Off	Monitor blanked when the systems enters the Suspend mode.
All Modes --> Off	Monitor blanked when the system enters any power saving mode.

---

**Video Off Method**

This determines the manner in which the monitor is blanked.

V/H SYNC+Blank	This selection will cause the system to turn off the vertical and horizontal synchronization ports and write blanks to the video buffer.
Blank Screen	This option only writes blanks to the video buffer.
DPMS Support	Select this option if your monitor supports the Display Power Management Signaling (DPMS) standard of the Video Electronics Standards to select video power management values.

---

**MODEM Use IRQ**

This determines the IRQ in which the MODEM can use.  
The choice: 3, 4, 5, 7, 9, 10, 11, NA.

---

**Soft-Off by PWRBTN**

Pressing the power button for more than 4 seconds forces the system to enter the Soft-Off state when the system has "hung."  
The choice: Delay 4 Sec, Instant-Off.

---

**State After Power Failure**

State after power is re-applied  
The choice: Auto, On, Off.

---

**Wake Up Event**

Wake Up events are I/O events whose occurrence can prevent the system from entering a power saving mode or can awaken the system from such a mode. In effect, the system remains alert for anything which occurs to a device which is configured as *On*, even when the system is in a power down mode.

---

**VGA**

When *On*, you can set the VGA awakens the system.

---

**LPT & COM**

When *On* of LPT & COM, any activity from one of the listed system peripheral devices or IRQs wakes up the system.

---

**HDD & FDD**

When *On of HDD & FDD*, any activity from one of the listed system peripheral devices wakes up the system.

---

**PCI Master**

When *On of PCI Master*, any activity from one of the listed system peripheral devices wakes up the system.

---

**Modem Ring Resume**

An input signal on the serial Ring Indicator (RI) line (in other words, an incoming call on the modem) and LAN WOL awakens the system from a soft off state.

---

**RTC Alarm Resume**

When *Enabled*, you can set the date and time at which the RTC (real-time clock) alarm awakens the system from Suspend mode.

The following is a list of IRQ's, Interrupt ReQuests, which can be exempted much as the COM ports and LPT ports above can. When an I/O device wants to gain the attention of the operating system, it signals this by causing an IRQ to occur. When the operating system is ready to respond to the request, it interrupts itself and performs the service.

When set *On*, activity will neither prevent the system from going into a power management mode nor awaken it.

- **Primary INTR**
- **IRQ3 (COM 2 )**
- **IRQ4 (COM 1)**
- **IRQ5 (LPT 2)**
- **IRQ6 (Floppy Disk)**
- **IRQ7 (LPT 1)**
- **IRQ8 (RTC Alarm)**
- **IRQ9 (IRQ2 Redir)**
- **IRQ10 (Reserved)**
- **IRQ11 (Reserved)**
- **IRQ12 ( PS / 2 Mouse )**
- **IRQ13 (Coprocessor)**
- **IRQ14 (Hard Disk)**
- **IRQ15 (Reserved).**

---

## 4.11 PNP/PCI CONFIGURATIONS

This section describes configuring the PCI bus system. PCI, or Personal Computer Interconnect, is a system which allows I/O devices to operate at speeds nearing the speed the CPU itself uses when communicating with its own special components. This section covers some very technical items and it is strongly recommended that only experienced users should make any changes to the default settings.

CMOS Setup Utility – Copyright © 1984-2001 Award Software

### PnP/PCI Configurations

PnP OS Installed	[No]	Item Help
Reset Configuration Data	[Disabled]	----- Menu Level >
Resources Controlled By	[Auto(ESCD)]	Default is Disabled. Select Enabled to reset Extended System Configuration Data(ESCD) when you exit Setup if you have installed a new add-on and the system reconfiguration has caused such a serious conflict that the OS cannot boot
x IRQ Resources	[Press Enter]	
x DMA Resources	[Press Enter]	
PCI/VGA Palette Snoop	[Disabled]	
Assign IRQ For VGA	[Enabled]	
Assign IRQ For USB	[Enabled]	
↑↓←→Move Enter: Select +/-/PU/PD: Value F10:Save ESC: Exit F1:General Help F5:Previous Values F6:Fail-safe defaults F7:Optimized Defaults		

---

### ***PNP OS Installed***

This item allows you to determine install PnP OS or not.  
The choice: Yes, No.

---

### ***Reset Configuration Data***

Normally, you leave this field Disabled. Select Enabled to reset Extended System Configuration Data (ESCD) when you exit Setup if you have installed a new add-on and the system reconfiguration has caused such a serious conflict that the operating system can not boot.  
The choice: Enabled, Disabled .

---

### ***IRQ Resources***

When resources are controlled manually, assign each system interrupt a type, depending on the type of device using the interrupt.

---

**IRQ3/4/5/7/9/10/11/12/14/15 assigned to**

This item allows you to determine the IRQ assigned to the ISA bus and is not available to any PCI slot. Legacy ISA for devices compliant with the original PC AT bus specification, PCI/ISA PnP for devices compliant with the Plug and Play standard whether designed for PCI or ISA bus architecture.

The Choice: *Legacy ISA* and *PCI/ISA PnP*.

---

**DMA Resource**

When resources are controlled manually, assign each system DMA channel a type, depending on the type of device using the DM channel.

---

**DMA 0/1/3/5/6/7 assigned to**

Legacy ISA for devices compliant with the original PC AT bus specification, PCI/ISA PnP for devices compliant with the Plug and Play standard whether designed for PCI or ISA bus architecture.

Choices are *Legacy ISA* and *PCI/ISA PnP*.

---

**PCI/VGA Palette Snoop**

Leave this field at *Disabled*.

The Choice: Enabled, Disabled.

---

**Assign IRQ For VGA**

Enable/Disable to assign IRQ for VGA

The Choice: Enabled, Disabled.

---

**Assign IRQ For USB**

Enable/Disable to assign IRQ for USB

The Choice: Enabled, Disabled.

---

#### 4.12 PC HEALTH STATUS

CMOS Setup Utility – Copyright © 1984-2001 Award Software

##### PC Health Status

Current CPU Temp.	40°C	Item Help
Current System Temp.	32°C	-----
Current CPU FAN Speed	5336RPM	Menu Level >
Vcore	1.78V	
2.5V	2.57V	
3.3V	3.32V	
5V	5.01V	
12V	12.35V	
↑↓←→ Move Enter: Select +/-/PU/PD: Value F10:Save ESC: Exit F1:General Help		
F5:Previous Values F6:Fail-safe defaults F7:Optimized Defaults		

#### 4.13 FREQUENCY/VOLTAGE CONTROL

CMOS Setup Utility – Copyright © 1984-2001 Award Software

##### Frequency/Voltage Control

Spread Spectrum	Disabled	Item Help
CPU Clock	Default	-----
		Menu Level >
↑↓←→ Move Enter: Select +/-/PU/PD: Value F10:Save ESC: Exit F1:General Help		
F5:Previous Values F6:Fail-safe defaults F7:Optimized Defaults		

---

##### **Spread Spectrum**

This item allows you to enable/disable the spread spectrum modulate.  
The choice: Enabled, Disabled.

---

##### **CPU Clock**

This item allows you to select CPU HOST frequency.  
The choice: 100~166MHz

---

#### **4.14 DEFAULTS MENU**

Selecting “Defaults” from the main menu shows you two options which are described below

##### **LOAD Fail-Safe DEFAULTS**

When you press <Enter> on this item you get a confirmation dialog box with a message similar to:

LOAD BIOS DEFAULTS (Y/N) ? **N**

Pressing ‘Y’ loads the BIOS default values for the most stable, minimal-performance system operations.

##### **LOAD Optimized DEFAULTS**

When you press <Enter> on this item you get a confirmation dialog box with a message similar to:

LOAD SETUP DEFAULTS (Y/N) ? **N**

Pressing ‘Y’ loads the default values that are factory settings for optimal performance system operations.

---

#### **4.15 SUPERVISOR/USER PASSWORD SETTING**

You can set either supervisor or user password, or both of them. The differences between are:

**supervisor password :**

can enter and change the options of the setup menus.

**user password :**

just can only enter but do not have the right to change the options of the setup menus. When you select this function, the following message will appear at the center of the screen to assist you in creating a password.

**ENTER PASSWORD:**

Type the password, up to eight characters in length, and press <Enter>. The password typed now will clear any previously entered password from CMOS memory. You will be asked to confirm the password. Type the password again and press <Enter>. You may also press <Esc> to abort the selection and not enter a password.

To disable a password, just press <Enter> when you are prompted to enter the password. A message will confirm the password will be disabled. Once the password is disabled, the system will boot and you can enter Setup freely.

**PASSWORD DISABLED.**

When a password has been enabled, you will be prompted to enter it every time you try to enter Setup. This prevents an unauthorized person from changing any part of your system configuration.

Additionally, when a password is enabled, you can also require the BIOS to request a password every time your system is rebooted. This would prevent unauthorized use of your computer.

You determine when the password is required within the BIOS Features Setup Menu and its Security option (see Section 3). If the Security option is set to password will be required both at boot and at entry to Setup. If set to "Setup", prompting only occurs when trying to enter Setup.

---

#### 4.16 Exit Selecting

##### **Save & Exit Setup**

Pressing <Enter> on this item asks for confirmation:

**Save to CMOS and EXIT (Y/N)?**

Pressing “Y” stores the selections made in the menus in CMOS – a special section of memory that stays on after you turn your system off. The next time you boot your computer, the BIOS configures your system according to the Setup selections stored in CMOS. After saving the values the system is restarted again.

##### **Exit Without Saving**

Pressing <Enter> on this item asks for confirmation:

**Quit without saving (Y/N)?**

This allows you to exit Setup without storing in CMOS any change. The previous selections remain in effect. This exits the Setup utility and restarts your computer.

## Appendix A. Watch-Dog Timer

The WatchDog Timer is a device to ensure that standalone systems can always recover from abnormal conditions that cause the system to crash. These conditions may result from an external EMI or a software bug. When the system stops working, hardware on the board will perform hardware reset (cold boot) to bring the system back to a known state.

Three I/O ports control the operation of WatchDog Timer.

443 (hex)	Write	Set WatchDog Time period
443 (hex)	Read	Enable the refresh the WatchDog Timer.
043/843 (hex)	Read	Disable the WatchDog Timer.

Prior to enable the WatchDog Timer, user has to set the time-out period. The resolution of the timer is 1 second and the range of the timer is from 1 sec to 255 sec. You need to send the time-out value to the I/O port – 443H, and then enable it by reading data from the same I/O port – 443H. This will activate the timer that will eventually time out and reset the CPU board. To ensure that this reset condition won't occur, the WatchDog Timer must be periodically refreshed by reading the same I/O port 443H. This must be done within the time-out period that is set by the software, please refer to the example program. Finally, we have to disable the WatchDog timer by reading the I/O port -- 843H or 043H. Otherwise the system could reset unconditionally.

*A tolerance of at least 5% must be maintained to avoid unknown routines in the operating system (DOS), such as disk I/O that can be very time-consuming. Therefore if the time-out period has been set to 10 seconds, the I/O port 443H must be read within 7 seconds.*

**Example assembly program:**

TIMER\_PORT = 443H

TIMER\_START = 443H

TIMER\_STOP = 843H

**;;Initial Timer Counter**

MOV DX, TIMER\_PORT

MOV AL, 8 ;;8 seconds

OUT DX, AL

MOV DX, TIMER\_START

IN AL, DX. ;;Start counter

W\_LOOP:

MOV DX, TIMER\_STOP

IN AL, DX

MOV DX, TIMER\_START

IN AL, DX ;;Restart counter

**;;Add Your Appliaction Here**

CMP EXIT\_AP, 0

JNE W\_LOOP

MOV DX, TIMER\_STOP

IN AL, DX

;;Exit AP

## Appendix B. E<sup>2</sup> Key™ Function

The JUKI3711PT/3712T provides an outstanding E<sup>2</sup>KEY™ function for system integrator. Based on the E<sup>2</sup>KEY™, you can free to store the ID Code, Password or Critical Data in the 1Kbit EEPROM. Because the EEPROM is nonvolatile memory, you don't have to worry for losing very important data.

Basically the E<sup>2</sup>KEY™ is based on a 1Kbit EEPROM which is configured to 64 words(from 0 to 63). You could access (read or write) each word at any time.

When you start to use the E<sup>2</sup>KEY™ you should have the utility in the package. The software utility will include four files as follows,

**README.DOC**  
**E2KEY.OBJ**  
**EKEYDEMO.C**  
**EKEYDEMO.EXE.**

The E2KEY.OBJ provides two library functions for user to integrate their application with E<sup>2</sup>KEY™ function. These library (**read\_e2key** and **write\_e2key**) are written and compiled in C language. Please check the following statement, then you will know how to implement it easily.

**unsigned int read\_e2key(unsigned int address)**

/\* This function will return the E<sup>2</sup>KEY™'s data at address. The address range is from 0 to 63. Return data is one word,16 bits

**\*/void write\_e2key(unsigned int address,unsigned data)**

/\* This function will write the given data to E<sup>2</sup>KEY™ at certain address. The address range is from 0 to 63. The data value is from 0 to 0xffff. \*/

To easily start to use the function, please refer to the included EKEYDEMO.C code at first.

## Appendix C. Address Mapping

---

### *IO Address Map*

<b>I/O address Range</b>	<b>Description</b>
000-01F	DMA Controller #1
020-021	Interrupt Controller #1, Master
040-05F	System timer
060-06F	Standard 101/102 Keyboard Controller
070-07F	Real time Clock, NMI Mask
080-09F	DMA Page Register
0A0-0BF	Interrupt Controller #2
0C0-0DF	DMA Controller #2
0F0	Clear Math Coprocessor Busy
0F1	Reset Math Coprocessor
0F2	Core logic programming configuration
0F8-0FF	Math Coprocessor
1F0-1F7	Fixed Disk
2F8-2FF	Serial Port 2
300-31F	Prototype Card
360-36F	Reserved
378-37F	Parallel Printer Port 1 (LPT1)
3B0-3BF	Monochrome Display
3C0-3CF	Color/Graphics Monitor Adapter
3D0-3DF	Color/Graphics Monitor Adapter
3F0-3F7	Diskette Controller
3F8-3FF	Serial Port 1
443	Start Watch Dog
843	Stop Watch Dog

---

**1st MB Memory Address Map**

Memory address	Description
00000-9FFFF	System memory
A0000-BFFFF	VGA buffer
C0000-C97FF	VGA BIOS
F0000-FFFFF	System BIOS
100000-	Extend BIOS

\*Default setting

---

**IRQ Mapping Table**

IRQ0	System Timer	IRQ8	RTC clock
IRQ1	Keyboard	IRQ9	Available
IRQ2	Cascade to IRQ Controller	IRQ10	Available
IRQ3	COM2	IRQ11	Available
IRQ4	COM1	IRQ12	PS2 mouse
IRQ5	Available	IRQ13	FPU
IRQ6	FDC	IRQ14	Primary IDE
IRQ7	Printer	IRQ15	Secondary IDE

---

**DMA Channel Assignments**

Channel	Function
0	Available
1	Available
2	Floppy disk ( 8-bit transfer )
3	Available
4	Cascade for DMA controller 1
5	Available
6	Available
7	Available

## Appendix D. ATX Power Supply

The following notes show how to connect ATX Power Supply to the backplanes and / or the ISBC card.

### A. For backplanes with ATX Connector

1. Please, disconnect the AC cord of the Power Supply from the AC source to prevent sudden electric surge to the board.
2. Please, check the type of your CPU board. All CPU board listed on the next page support ATX power supply but has two types of power switch connection:

#### 2.1. JUKI3711PT/3712T(through Power Button & GND):

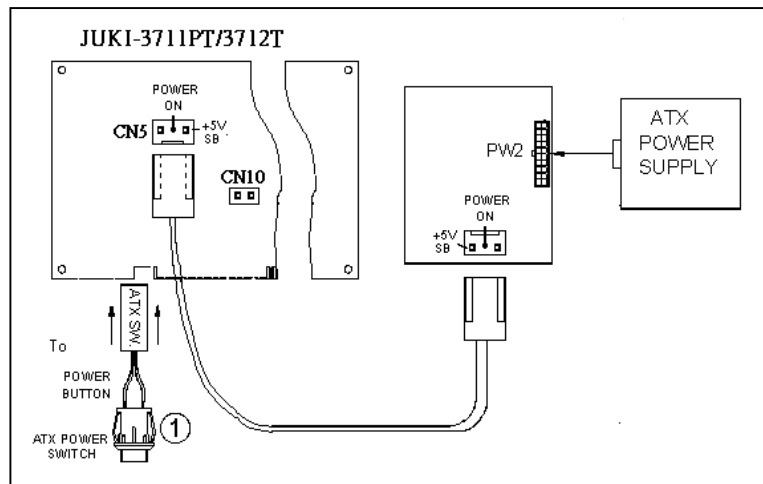

Connect the ATX power button switch to the CN10 (power button). And connect the power cable from Backplane to CN5 of CPU card.

If you want to turn ON the system, just press the button once.  
And if you want to turn off the power supply, please press the ATX power switch button for about 4 seconds.

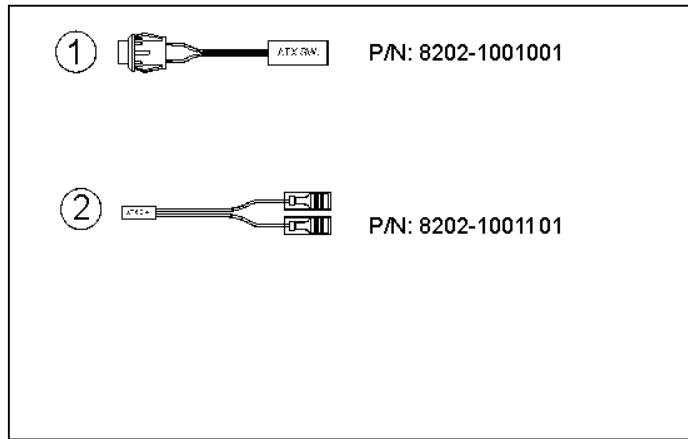

**B. For the backplanes with ATX power supply connector**

For some SBC without ATX power ON/OFF function, then you can control the ATX power supply through backplane's PS ON connector. Refer to the figure below: for the backplanes with ATX connector, the connection can be made simply as following:

1. Connect the ON/OFF (ordinary one) switch to Pin 2 (PS ON) and Pin 3 (GND) of connector CN2
2. You may now turn the power ON/OFF by the power switch

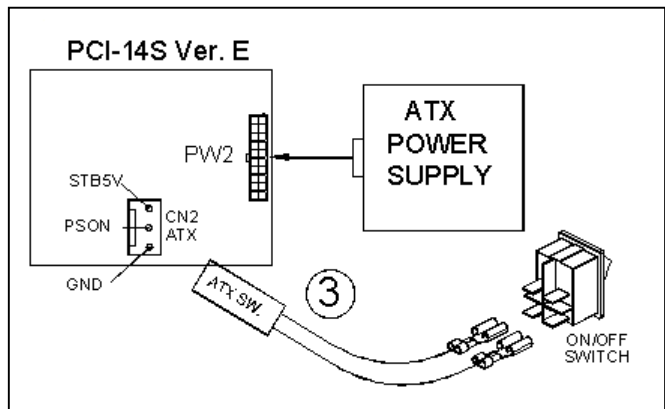

## Appendix E. How to use Wake-Up Function

The JUKI3711PT/3712T provides two kind of Wake up Function. This page describes how to use Modem Wake-Up and LAN Wake-Up function.

Wake-Up function is working while you use ATX power supply,

### **Wake –Up On Modem(Ring) :**

You must set the option **Modem Ring Resume** of CMOS SETUP to be enabled. The ATX power supply will be switched on when there is a ring signal detected on pin “RI” of serial port.

### **Wake-Up On LAN:**

When your computer is in power-down status, you can see LAN Link/Active LED is flashing. This status indicates that the LAN chip has entered standby mode and waits for Wake-Up signal. You can use other computers to wake up your computer by sending ID to it.

ID: ID is the address of your system LAN. Every LAN chip has a factory-set ID, which you can find it from network information in WINDOWS.

ID's format is xxxxxxxxxxxx

**Example ID:** 009027388320