

AP-520-LP266

Full-size CPU Card with Intel Pentium[®]

MMX-266 Low Power CPU

COPYRIGHT[©]

This document is a copyright of the original manufacturer, 2000. The original manufacturer reserves the right to make improvements to the product(s) described in this manual at any time without notice. This manual may not, in whole or in part, be photocopied, reproduced, transcribed, translated, or transmitted in whatever form without the written consent of the manufacturer, except for copies retained by the purchaser for backup purposes. All rights are reserved.

TRADEMARKS[™]

Pentium[®] is a registered trademark of Intel Corporation.

The following are trademarks or registered trademarks of their respective companies: IBM, Intel, AMD, Cyrix, Award, AMI, Microsoft, Windows, Windows NT, Novell, SCO, PC/104, PICMG, ALI, UMC, SMC, Winbond. Products mentioned in this manual are mentioned for identification purposes only. All names of products or services appearing in this manual are the trademarks or registered trademarks of their respective organizations and companies.

© Copyright 2000

Ver. No. V1.0
LEI-UM-AP520-LP266
Date : 2000/7/5

TABLE OF CONTENTS

CHAPTER 1	INTRODUCTION	1
1.1	SPECIFICATION	2
1.2	PACKING CHECK LIST	3
CHAPTER 2	JUMPER SETTINGS AND CONNECTORS	4
2.1	BOARD OUTLINE OF AP-520-LP266	4
2.2	JUMPER SETTING OVERVIEW	5
2.3	INSTALLING THE DIMM MODULE	5
2.4	JUMPER LOCATION FOR AP-520-LP266	6
2.5	JUMPER SETTINGS SUMMARY FOR AP-520-LP266	7
2.6	I/O CONNECTORS LOCATION FOR AP-520-LP266	11
2.7	I/O CONNECTORS SUMMARY FOR AP-520-LP266	12
2.8	I/O CONNECTORS DESCRIPTION	13
CHAPTER 3	AWARD BIOS SETUP	24
3.1	RUNNING AWARD BIOS	24
3.2	CMOS SETUP UTILITY	25
3.3	STANDARD CMOS SETUP	26
3.4	BIOS FEATURES SETUP	31
3.5	CHIPSET FEATURES SETUP	34
3.6	POWER MANAGEMENT SETUP	37
3.7	PNP/PCI CONFIGURATION	40
3.8	LOAD BIOS DEFAULTS	42
3.9	LOAD SETUP DEFAULTS	42
3.10	INTEGRATED PERIPHERALS	43
3.11	SUPERVISOR / USER PASSWORD	45
3.12	IDE HDD AUTO DETECTION	45
3.13	HDD LOW LEVEL FORMAT	46
3.14	SAVE & EXIT SETUP	46
3.15	EXIT WITHOUT SAVING	46
CHAPTER 4	DRIVERS SUPPORT	47
APPENDIX A	HOW TO USE WATCH-DOG TIMER	48
APPENDIX B	TECHNICAL REFERENCE	49
GLOSSARY		51
TERMS AND CONDITIONS		
RMA SERVICE REQUEST FORM		

CHAPTER 1.

INTRODUCTION

The AP-520-LP266 is a full-size PCI/ISA single board computer with Low-Power Pentium® MMX 266 MHZ CPU onboard that is using the Intel' s chipset 82430TX that supports the Ultra DMA-33 for faster hard drive and the Health monitoring hardware. The health monitoring hardware detects and releases a sound alarm for any abnormal function of the operating voltage & temperature of CPU or it' s cooling fan. For boosting operation, this motivated card also supports sockets for a Flash Disk, two DIMMs. It offers the function of an industrial computer on a single board with on-board 2nd level cache RAM of 512KB for maximum performance.

The AP-520-LP266 is built as a PCI/ISA expansion card that is simply upgraded by changing one card from another without replacing the whole system. It provides the primarily elements for building an IBM PC/AT compatible computer for a wide variety of applications with system integration. The AP-520-LP266 is fully compatible with the IBM PC/AT which means virtually all the software written for the IBM PC/AT will run on the AP-520-LP266 SBC.

Other on-board features include two serial ports (RS-232 and RS-232/422/485), one multi-mode parallel (ECP/EPP/SPP) port, a floppy drive controller and a keyboard interface and a PS/2 mouse interface. The built-in high speed PCI IDE controller supports both PIO and bus master modes. Up to four IDE devices can be connected, including large hard disks, CD-ROM drives, tape backup drives and other IDE devices. Its 6-layer printed circuit board combines with noise-tolerant and low power consumption CMOS technology applied on the board makes AP-520-LP266 able to withstand any harsh industrial environments very well.

1.1 SPECIFICATION

- ❑ Processor : Intel Pentium MMX-266 Lower Power CPU onboard
- ❑ Chipset : Intel 430TX chipset, Genesys 518SM, Winbond 977TF I/O chipset
- ❑ System Memory : Two DIMM sockets, support up to 256MB SDRAM
- ❑ Cache Memory : 512KB pipeline burst secondary cache
- ❑ BIOS : 128KB Award license BIOS
- ❑ Flash Memory Disk : Reserved socket for DiskOnChip from M-System , support up to 144 MB flash memory disk
- ❑ IDE Drive Interface : Two PCI IDE port, support up to four IDE devices and Ultra DMA-33
- ❑ Floppy Drive Interface : One FDD port, support up to two floppy devices
- ❑ Serial Port : Two COM ports, one RS-232 and one RS-232 / 422 / 485
- ❑ Parallel Port : One multi-mode parallel port (SPP/EPP/ECP)
- ❑ Bus Interface : ISA/PCI bus (PICMG)
- ❑ RTC Battery : Dallas RTC battery or compatible
- ❑ PS/2 Mouse & Keyboard Connector : On-board 6-pin Mini-Din PS/2 mouse & PS/2 keyboard connector
- ❑ Watchdog Timer : Hardware 7 level time-out intervals (0.5/1/2/4/16/32/64 sec.); Software 16 level time-out intervals (0/2/4/6/8/10/12/14/16/18/20/22/24/26/28/30 sec.)
- ❑ Digital I/O : 4 bit Digital input / 4 bit Digital output
- ❑ Universal Serial Bus : Support 2 USB ports
- ❑ IR Interface : Supports one IrDA header
- ❑ PC/104 Expansion Bus : Built-in PC/104 expansion bus
- ❑ ISA High-Drive : Support up to 20 ISA slots capability (Optional)
- ❑ Health Monitoring : On-board Genesys 518SM, support CPU temperature alarm
- ❑ Operating Temperature : 0°C ~ 60°C
- ❑ Humidity : 10% ~ 90% RH
- ❑ Dimensions : 338 x 122 mm (13 1/4" x 4 5/6" inches)

1.2 PACKING CHECK LIST

Before you begin to install your card, please make sure that you received the following materials as listed below:

<i>Item</i>	<i>Qty</i>	<i>Remark</i>
AP-520-LP266 CPU onboard Computer	1 pcs	AP-520-LP266 SBC
Keyboard cable	1 pcs	6-pin keyboard connector
LPT cable	1 pcs	26-pin standard header to 25-pin female D-Sub
Hard Disk/FDD Cable	1 pcs	40-pin to 40-pin standard header flat ribbon cable 34-pin to 34-pin standard header flat ribbon cable
CD-ROM	1 pcs	Drivers
Keyboard adapter cable	1 pcs	5-pin female connector to 5-pin female connector
User' s manual	1 pcs	AP-520-LP266

CHAPTER 2.

JUMPER SETTINGS AND CONNECTORS

The figure below shows the jumpers and connectors location on the AP-520-LP266:

2.1 BOARD OUTLINE OF AP-520-LP266

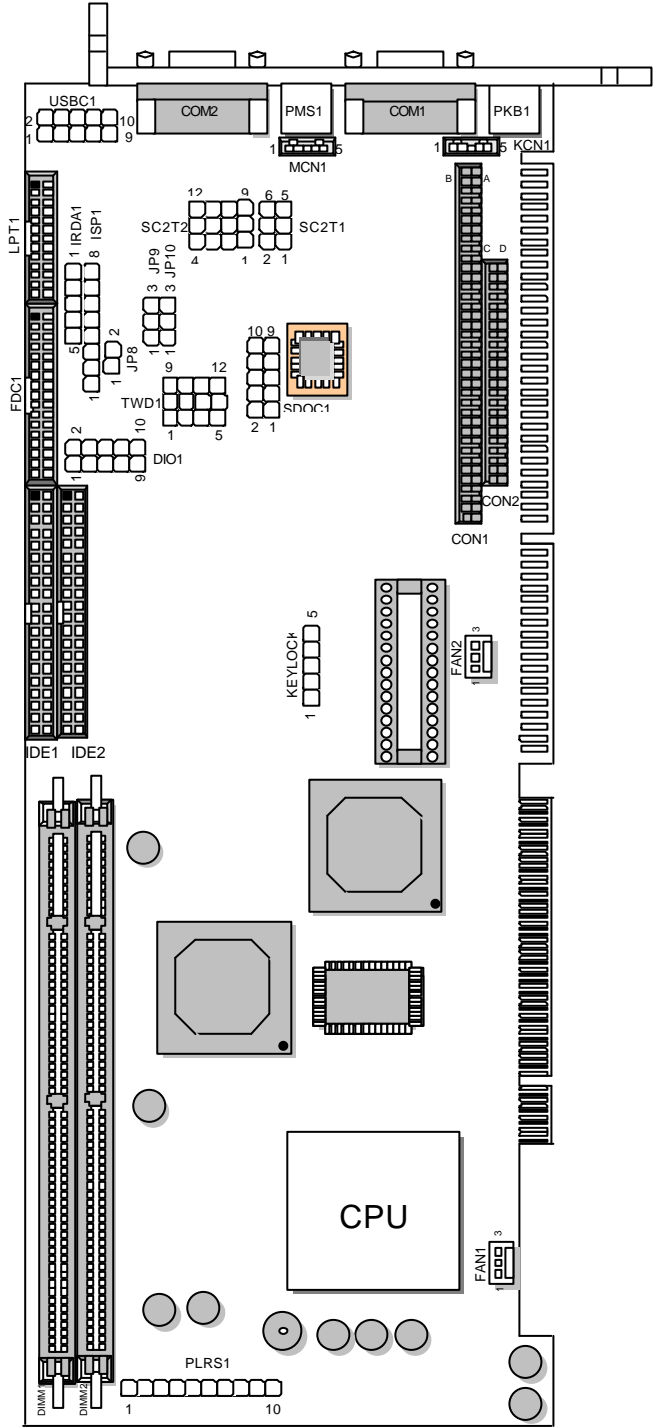

2.2 JUMPER SETTING OVERVIEW

In order to select the operation modes of your system, configure and set the jumpers on your single board computer to match the need of your application. To set a jumper, a black plastic cap containing metal contacts is placed over the jumper pins as designated by the required configuration as listed in this section. A jumper is said to be “ on ” or “ 1-2 ” when the black cap has been placed on two of its pins, as show in the figure below:

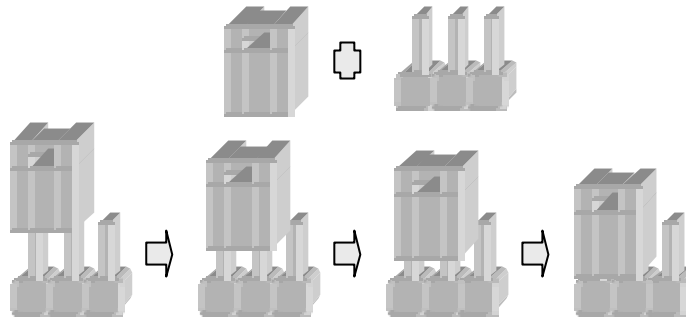

A pair of needle-nose pliers is recommended when working with jumpers. If you have any doubts about the best hardware configuration for your application, contact your local sales representative before you make any changes. In general, you simply need a standard cable to make most connections.

2.3 INSTALLING THE DIMM MODULE

A DIMM module simply snaps into a socket on the system board. Pin1 of the DIMM module must correspond with Pin1 of the socket.

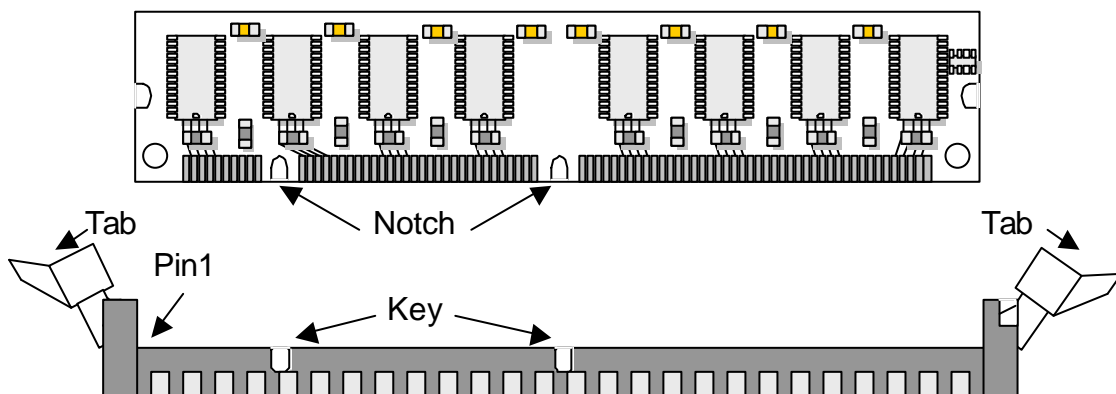

1. Position the DIMM above the socket with the “notch” in the module aligned with the “key” on the socket.
2. Seat the module at a 90 angle into the bank. Make sure it is completely seated. Push down the module until handles of the socket lock up-right and up-left notches.

2.4 JUMPER LOCATION FOR AP-520-LP266

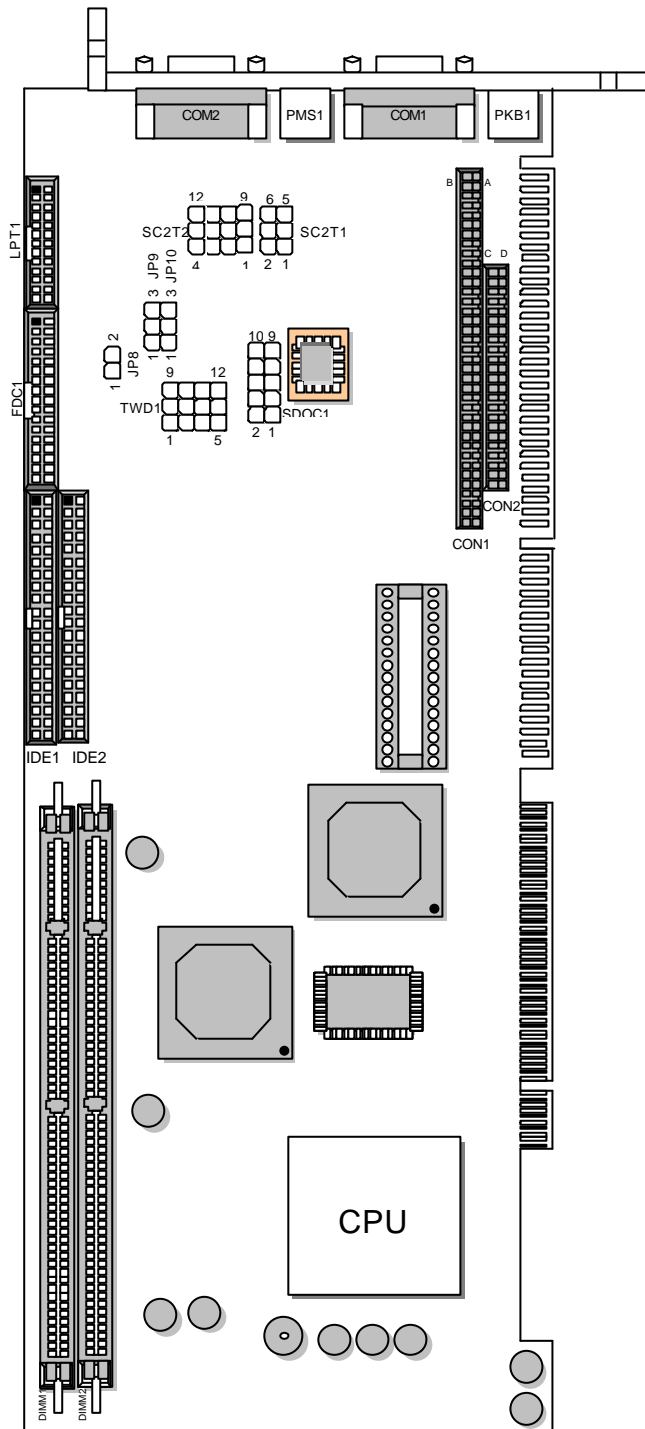

2.5 JUMPER SETTINGS SUMMARY FOR AP-520-LP266

LOCATION	FUNCTION
JP8 &TWD1	Select Software Watch-Dog or Hardware Watch-Dog
TWD1	Select Watch-Dog Time Out Period
SC2T1 / SC2T2	Select COM2 Type
JP9	Default Setting
JP10	Default Setting
SDOC1	Select DiskOnChip (Flash Disk) & SRAM Address

● **JP8 & TWD1 : Select Software Watch-Dog or Hardware Watch-Dog**

Type	JP8	TWD1
Hardware (Default)	ON	See Below
Software	OFF	7-11 (Fixed)

● **TWD1 : Select Watch-Dog Time Out Period**

Time Out Period	Twd1
0.5 sec	1-5
1 sec	2-6
2 sec	3-7
4 sec (Default)	4-8
16 sec (S/W Fixed)	7-11
32 sec	6-10
64 sec	5-9

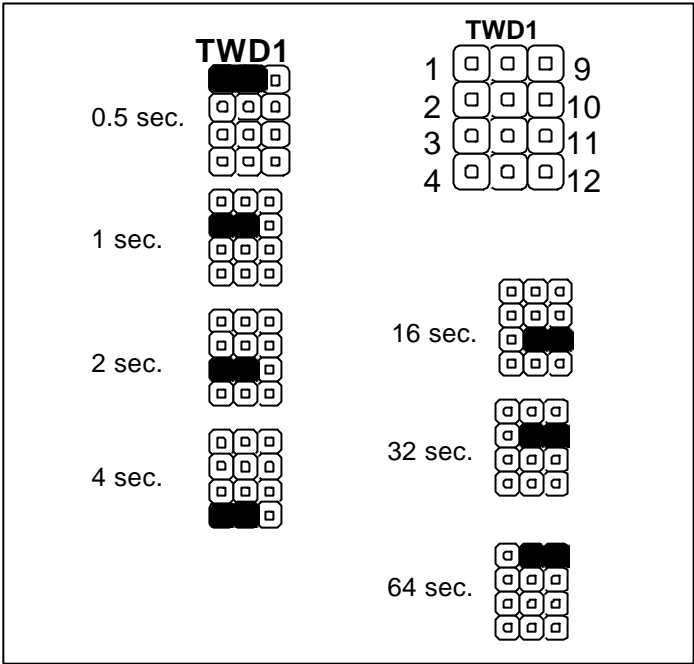
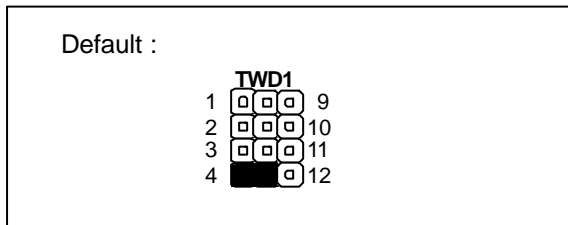

● **SC2T1 / SC2T2 : Select COM2 Type**

COM2 Type	SC2T1	SC2T2
RS-232 (Default)	1-2	5-9,6-10,7-11,8-12
RS-422	3-4	1-5,2-6,3-7,4-8
RS-485	5-6	1-5,2-6,3-7,4-8

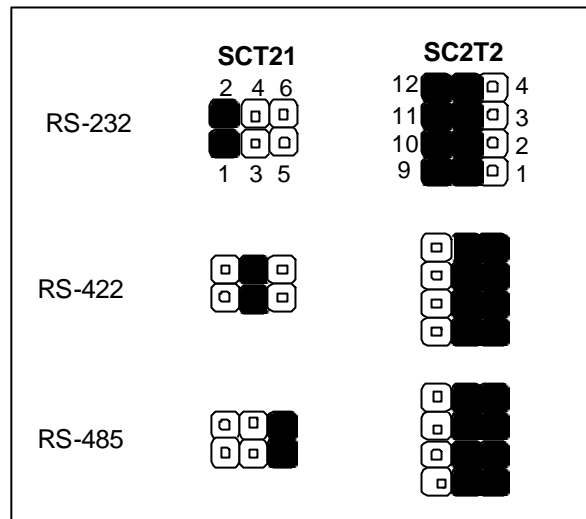
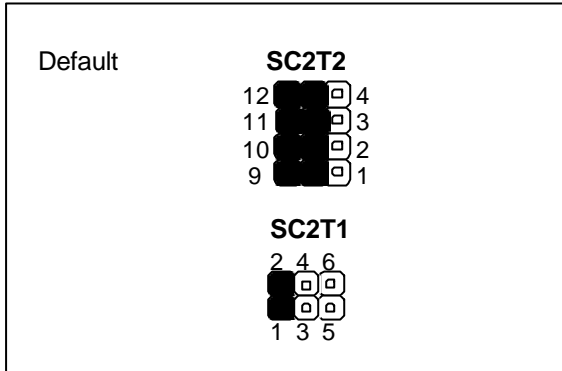

- **JP9 : Default Setting(1-2)**

- **JP10: Default Setting(1-2)**

JUMPER SETTING & CONNECTORS

● **SDOC1 : Select DiskOnChip (Flash Disk) & SRAM Address**

Flash Disk Address	SDOC1
CC00H~CDFFH	1-2,9-10
D000H~D1FFH	3-4,7-8
D400H~D5FFH	3-4,9-10
D800H~D9FFH	5-6,7-8
DC00H~DDFFH	5-6,9-10

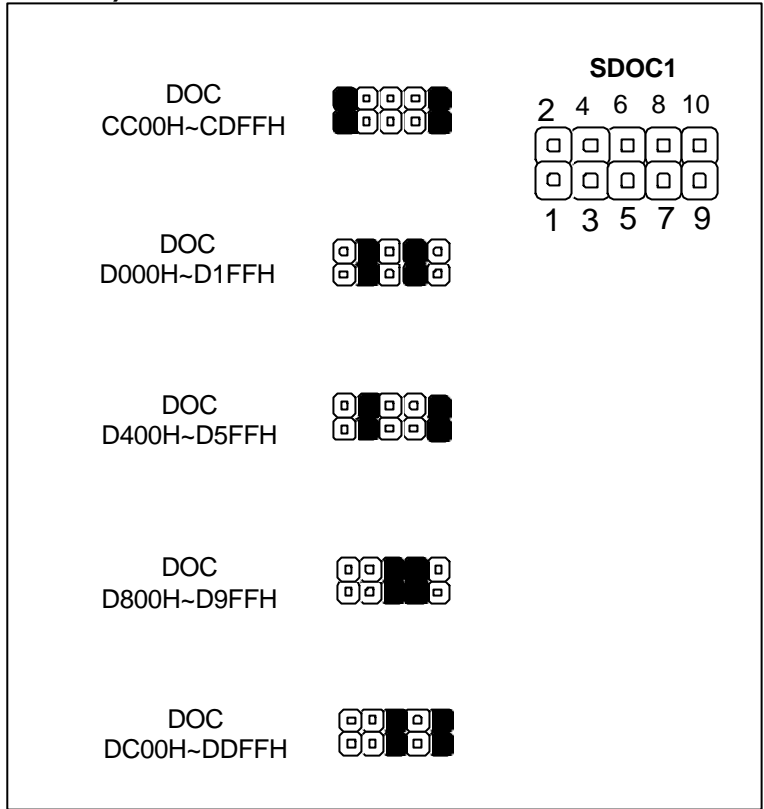
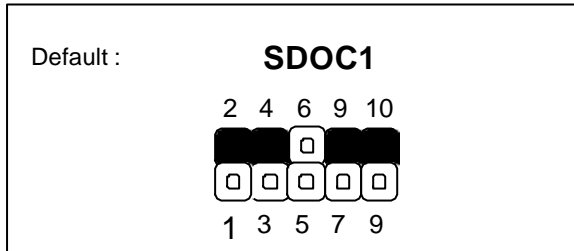

2.6 I/O CONNECTOR LOCATION FOR AP-520-LP266

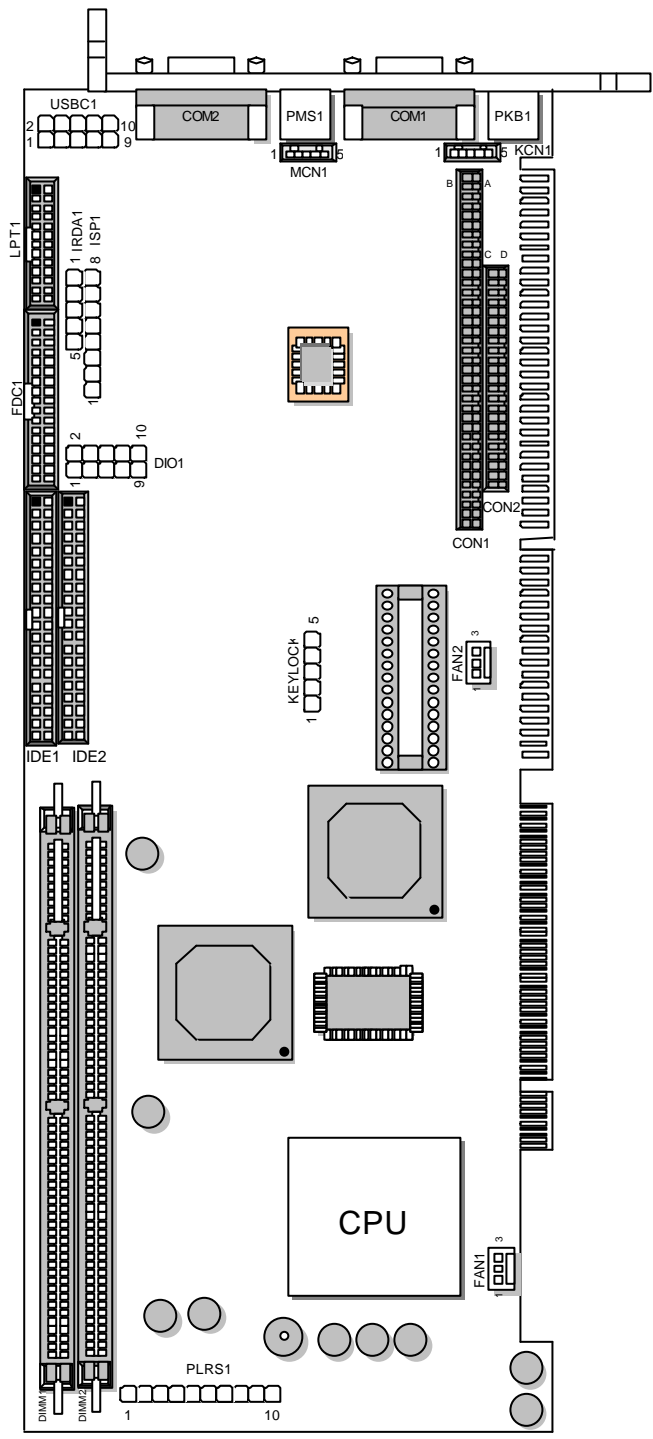

2.7 I/O CONNECTOR SUMMARY OF AP-520-LP266

CONNECTOR	FUNCTION
USBC1	USB Port #1 & #2 Connector
KCN1	5 Pin Keyboard Cable Connector
COM1	RS-232 Serial Port #1 Connector (D-Sub)
COM2	Serial Port #2 Connector (D-Sub)
MCN1	5 Pin Mouse Cable Connector
ISP1	ISP GAL Connector (Factory only)
PKB1	PS/2 Keyboard Connector (Mini Din)
PMS1	PS/2 Mouse Connector (Mini Din)
PLRS1	Power LED, Reset, Speaker Connector
IDE1	Primary IDE Cable Connector
IDE2	Secondary IDE Cable Connector
FDC1	Floppy Interface Connector
LPT1	Parallel Connector
DIO1	Digital Input / Digital Output Ports
CON1, CON2	PC/104 Connector
IRDA1	Alternate IrDA
KEYLOCK	1&3:POWER LED, 4-5:KEYLOCK
FAN1	FAN Connector #1
FAN2	FAN Connector #2

2.8 I/O CONNECTORS DESCRIPTION

● USBC1 : USB Port #1 & #2 Connector

PIN NO.	DESCRIPTION	PIN NO.	DESCRIPTION
1	USB Port #0 Vcc	2	USB Port #1 Vcc
3	USB D0-	4	USB D1-
5	USB D0+	6	USB D1+
7	Ground	8	Ground
9	USB Port #0 Ground	10	USB Port #1 Ground

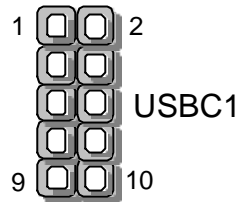

● KCN1 : 5 Pin Keyboard Cable Connector

PIN NO.	DESCRIPTION
1	Keyboard Clock
2	Keyboard Data
3	NC
4	Ground
5	+5V

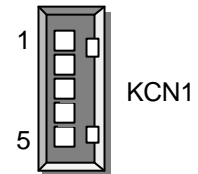

● **COM1 : RS-232 Serial Port #1 Connector (D-Sub)**

PIN NO.	DESCRIPTION
1	Data Carrier Detect (DCDA #)
2	Receive Data (RXDA)
3	Transmit Data (TXDA)
4	Data Terminal Ready (DTRA #)
5	Ground (GND)
6	Data Set Ready (DSRA #)
7	Request To Send (RTSA #)
8	Clear To Send (CTSA #)
9	Ring Indicator (RIA #)

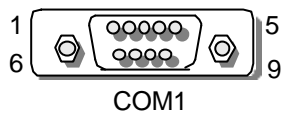

● **COM2 : Serial Port #2 Connector (D-Sub)**

PIN NO.	DESCRIPTION		
	RS-232	RS-422	RS-485
1	Data Carrier Detect (DCDB #)	TXD-	Data-
2	Receive Data (RXDB)	TXD+	Data+
3	Transmit Data (TXDB)	RXD+	NC
4	Data Terminal Ready (DTRB #)	RXD-	NC
5	Ground (GND)	NC	NC
6	Data Set Ready (DSRB #)	NC	NC
7	Request To Send (RTSB #)	NC	NC
8	Clear To Send (CTSB #)	NC	NC
9	Ring Indicator (RIB #)	NC	NC

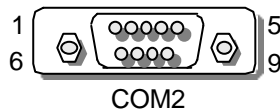

● **MCN1 : 5 Pin Mouse Cable Connector**

PIN NO.	DESCRIPTION
1	Mouse Data
2	NC
3	Ground
4	+5V
5	Mouse Clock

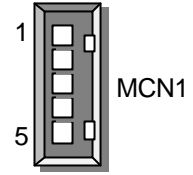

● **ISP1: ISP GAL Connector (Factory only)**

PIN NO.	DESCRIPTION
1	VCC
2	SDO
3	SDI
4	ISP
5	NC
6	MODE
7	Ground
8	SCLK

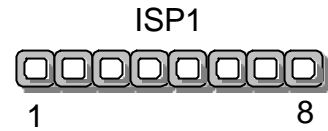

● **PKB1 : PS/2 Keyboard Connector (Mini Din)**

PIN NO.	DESCRIPTION
1	PS/2 Keyboard Data
2	NC
3	Ground
4	VCC
5	PS/2 Keyboard Clock
6	NC

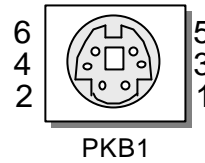

● **PMS1 : PS/2 Mouse Connector (Mini Din)**

PIN NO.	DESCRIPTION
1	PS/2 Mouse Data
2	NC
3	Ground
4	VCC
5	PS/2 Mouse Clock
6	NC

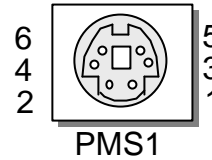

● **KEYLOCK : POWER LED & KEYLOCK CONNECTOR**

PIN NO.	DESCRIPTION
1	+5V
2	NC
3	GND
4	Key lock Signal
5	GND



● **PLRS1 : Power LED, Reset, Speaker Connector**

PIN NO.	DESCRIPTION
1	Power LED +
2	GND
3	HDD LED +
4	HDD LED -
5	RESET SW +
6	RESET SW – (GND)
7	External Speaker -
8	Internal Buzzer -
9	NC
10	External Speaker +

Default :

7-8 (ON)

Internal Buzzer

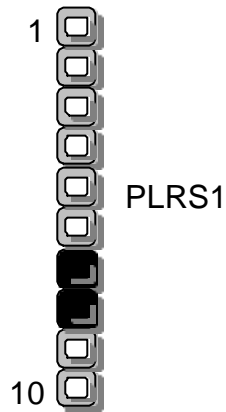

● IDE1 : Primary IDE Cable Connector (Header)

PIN NO.	DESCRIPTION	PIN NO.	DESCRIPTION
1	Reset #	2	Ground
3	Data 7	4	Data 8
5	Data 6	6	Data 9
7	Data 5	8	Data 10
9	Data 4	10	Data 11
11	Data 3	12	Data 12
13	Data 2	14	Data 13
15	Data 1	16	Data 14
17	Data 0	18	Data 15
19	Ground	20	NC
21	DMA REQ	22	Ground
23	IOW #	24	Ground
25	IOR #	26	Ground
27	IOCHRDY	28	NC
29	DMA ACK #	30	Ground
31	Interrupt	32	IOCS16 #
33	SA1	34	NC
35	SA0	36	SA2
37	HDC CS0 #	38	HDC CS1 #
39	HDD Active LED #	40	Ground

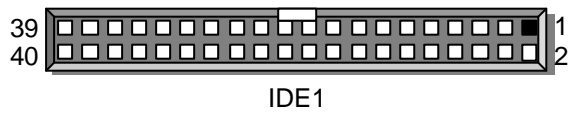

● IDE2 : Secondary IDE Cable Connector (Header)

PIN NO.	DESCRIPTION	PIN NO.	DESCRIPTION
1	Reset #	2	Ground
3	Data 7	4	Data 8
5	Data 6	6	Data 9
7	Data 5	8	Data 10
9	Data 4	10	Data 11
11	Data 3	12	Data 12
13	Data 2	14	Data 13
15	Data 1	16	Data 14
17	Data 0	18	Data 15
19	Ground	20	NC
21	DMA REQ	22	Ground
23	IOW #	24	Ground
25	IOR #	26	Ground
27	IOCHRDY	28	NC
29	DMA ACK #	30	Ground
31	Interrupt	32	IOCS16 #
33	SA1	34	NC
35	SA0	36	SA2
37	HDC CS0 #	38	HDC CS1 #
39	HDD Active LED #	40	Ground

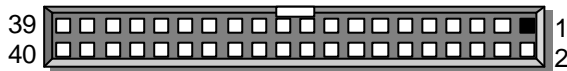

IDE2

● **FDC1 : Floppy Interface Connector (Header)**

PIN NO.	DESCRIPTION	PIN NO.	DESCRIPTION
1	Ground	2	Density Select
3	Ground	4	NC
5	Ground	6	DS1
7	Ground	8	Index #
9	Ground	10	Motor Enable A #
11	Ground	12	Drive Select B #
13	Ground	14	Drive Select A #
15	Ground	16	Motor Enable B #
17	Ground	18	Direction #
19	Ground	20	Step #
21	Ground	22	Write Data #
23	Ground	24	Write Gate #
25	Ground	26	Track 0 #
27	Ground	28	Write Protect #
29	NC	30	Read Data #
31	Ground	32	Head Side Select #
33	NC	34	Disk Change #

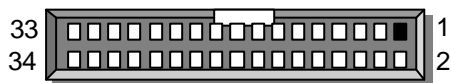

FDC1

● **LPT1 : Parallel Connector (Header)**

PIN NO.	DESCRIPTION	PIN NO.	DESCRIPTION
1	Strobe #	2	Auto Form Feed
3	Data0	4	Error #
5	Data1	6	Initialize #
7	Data2	8	Printer Select IN #
9	Data3	10	Ground
11	Data4	12	Ground
13	Data5	14	Ground
15	Data6	16	Ground
17	Data7	18	Ground
19	Acknowledge #	20	Ground
21	Busy	22	Ground
23	Paper Empty	24	Ground
25	Printer Select	26	Ground

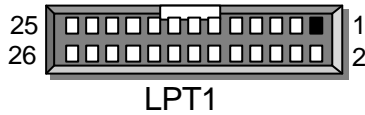

● **DIO1 : Digital Input / Digital Output (Header)**

PIN NO.	DESCRIPTION	PIN No.	DESCRIPTION
1	IN0	2	OUT0
3	IN1	4	OUT1
5	IN2	6	OUT2
7	IN3	8	OUT3
9	Ground	10	Ground

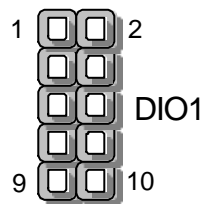

JUMPER SETTING & CONNECTORS

● CON1, CON2 : PC/104 Connector

PIN NO	DESCRIPTION			
	CON1		CON2	
	Row A	Row B	Row A	Row B
1	IOCHCK#	Ground	Ground	Ground
2	SD7	RSTDRV	SBHE#	MEMCS16#
3	SD6	+5V	LA23	IOCS16#
4	SD5	IRQ9	LA22	IRQ10
5	SD4	-5V	LA21	IRQ11
6	SD3	DRQ2	LA20	IRQ12
7	SD2	-12V	LA19	IRQ15
8	SD1	0 WS#	LA18	IRQ14
9	SD0	+12V	LA17	DACK0#
10	IOCHRDY	NC	MEMR#	DRQ0
11	AEN	SMEMW#	MEMW#	DACK5#
12	SA19	SMEMR#	SD8	DRQ5
13	SA18	IOW#	SD9	DACK6#
14	SA17	IOR#	SD10	DRQ6
15	SA16	DACK3#	SD11	DACK7#
16	SA15	DRQ3	SD12	DRQ7
17	SA14	DACK1#	SD13	+5V
18	SA13	DRQ1	SD14	MASTER#
19	SA12	REFRESH#	SD15	Ground
20	SA11	SYSCLK	NC	Ground
21	SA10	IRQ7	---	---
22	SA9	IRQ6	---	---
23	SA8	IRQ5	---	---
24	SA7	IRQ4	---	---
25	SA6	IRQ3	---	---
26	SA5	DACK2#	---	---
27	SA4	TC	---	---
28	SA3	BALE	---	---
29	SA2	+5V	---	---
30	SA1	OSC	---	---
31	SA0	Ground	---	---
32	Ground	Ground	---	---

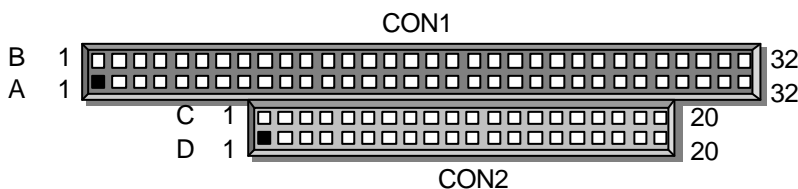

● **IRDA1 : Alternate IrDA**

PIN NO	DERCRIPTION
1	VCC
2	NC
3	IRRX
4	GND
5	IRTX



● **FAN1 : FAN Connector**

PIN NO	DERCRIPTION
1	Ground
2	+12V
3	FAN Status



● **FAN2 : FAN Connector**

PIN NO	DERCRIPTION
1	Ground
2	+12V
3	FAN Status



CHAPTER 3.

AWARD BIOS SETUP

Award's ROM BIOS provides a built-in Setup program that allows user to modify the basic system configuration and settings. The modified data will be stored in a battery-backed CMOS RAM so that these data will be retained even when the power is turned off. In general, the information saved in the CMOS RAM stay unchanged unless there is configuration change in the system, such as hard drive replacement or new equipment is installed.

3.1 RUNNING AWARD BIOS

The Setup Utility is stored in the BIOS ROM. When the power of the computer system is turned on, a screen message appears to give you an opportunity to call up the Setup Utility; while the BIOS will enter the Power On Self Test (POST) routines. The POST routines perform various diagnostic checks while initializing the board hardware. If the routines encounter an error during the tests, the error will be reported in either of the two different ways, hear a series of short beeps or see an error message on the screen display. There are two kinds of error: fatal or non-fatal. The system can usually continue to boot up sequence with the non-fatal errors. Non-fatal error messages usually appear on the screen along with the following instructions:

“ Press <F1> to RESUME ”

Write down the message and press the F1 key to continue the boot up sequence. After the POST routines are completed, the following message appears:

“ Press DEL to enter SETUP ”

Entering Setup

Turn on the power of the computer system and press immediately. If you don't have the chance to respond, reset the system by simultaneously typing the <Ctrl>, <Alt> and <Delete> keys, or by pushing the ' Reset ' button on the system cabinet. You can also restart by turning the system OFF then ON.

3.2 CMOS SETUP UTILITY

To access the AWARD BIOS SETUP program, press the key. The screen display will appear as :

Main Program Screen

ROM PCI / ISA BIOS (2A59IL7P) CMOS SETUP UTILITY AWARD SOFTWARE, INC.	
STANDARD CMOS SETUP BIOS FEATURES SETUP CHIPSET FEATURES SETUP POWER MANAGEMENT SETUP PNP / PCI CONFIGURATION LOAD BIOS DEFAULTS LOAD SETUP DEFAULTS	INTEGRATED PERIPHERALS SUPERVISOR PASSWORD USER PASSWORD IDE HDD AUTO DETECTION HDD LOW LEVEL FORMAT SAVE & EXIT SETUP EXIT WITHOUT SAVING
ESC : Quit F10 : Save & Exit Setup	↑ ↓ → ← : Select Item (Shift) F2 : Change Color
Time, Date, Hard Disk Type....	

This screen provides access to the utility's various functions.

Listed below are explanation of the keys displayed at the bottom of the screen:

<ESC> : Exit the utility.

ARROW KEYS : Use arrow keys ↑ ↓ → ← to move cursor to your desired selection.

<F10> : Saves all changes made to Setup and exits program.

<Shift><F2> : Changes background and foreground colors.

3.3 STANDARD CMOS SETUP

When you select the “STANDARD CMOS SETUP” on the main program, the screen display will appear as :

Standard CMOS Setup Screen

ROM PCI / ISA BIOS(2A59IL7P)									
STANDARD CMOS SETUP									
AWARD SOFTWARE, INC.									
Date (mm : dd : yy)	: Mon, Dec 13 1999								
Time (hh : mm : ss)	: 17:41:25								
HARD DISKS	TYPE	SIZE	CYLS.	HEADS	PRECOMP	LANDZ	SECTORS	MODE	
Primary Master	: Auto	0	0	0	0	0	0	AUTO	
Primary Slave	: Auto	0	0	0	0	0	0	AUTO	
Secondary Master	: Auto	0	0	0	0	0	0	AUTO	
Secondary Slave	: Auto	0	0	0	0	0	0	AUTO	
Drive A	: 1.44M, 3.5 in.								
Drive B	: None								
Video	: EGA/VGA								
Halt On	: All Errors								
			Base Memory : 640K Extended Memory : 130048K <u>Other Memory : 384K</u> Total Memory : 131072K						
ESC	: Quit		↑ ↓ → ← : Select Item			PU / PD / + / - : Modify			
F1	: Help		(Shift) F2 : Change Color						

The Standard CMOS Setup utility is used to configure the following components such as date, time, hard disk drive, floppy drive, display, and memory. Once a field is highlighted, on-line help information is displayed in the left bottom of the Menu screen.

Set Date : Month, Date, Year.

Set Time : Hour, Minute and Second. Use 24 Hour clock format (for p.m. time, add 12 to the hour number, you would enter 4:30p.m. as 16:30). When you select the “STANDARD CMOS SETUP” on the main program, the screen display will appear as :

Hard Disks : There are four hard disks listed: "Primary Master", "Primary Slave", "Secondary Master" and "Secondary Slave". For each IDE channel, the first device is the "Master" and the second device is "Slave". Hard disk types from 1 to 45 are the standard ones. To select or change the configuration, move the cursor to the desired position and press <Page Up> or <Page Down> to change the option : (1) Press "Auto" for IDE HDD auto detection, (2) Press "User" for user definable, and Press "None" for not installed (e.g. SCSI). There are six categories of information that you must enter for a HDD: "CYLS." for (number of cylinders), "HEADS" for (number of heads), "PRECOMP" for (write pre-compensation), "LANDZ" for (landing zone), "SECTOR" for (number of sectors) and "MODE" for (Normal, LBA, LARGE and AUTO). The hard disk vendor's or system manufacturer's documentation should provide you with the drive specifications. For an IDE hard drive, you can set "TYPE" to "Auto" or use the "IDE HDD AUTO DETECTION" utility in the main program screen to enter the drive specifications.

Here is a brief explanation of drive specifications:

- Type : The BIOS contains a table of pre-defined drive types. Each defined drive type has specified number of cylinders, number of heads, write compensation factor, landing zone, and number of sectors. Drives whose specifications do not accommodate any pre-defined type are classified as type USER.
- Size : Disk drive capacity (approximate). Note that this size is usually slightly greater than the size of a formatted disk given by a diskchecking program.
- Cyls : Number of cylinders.
- Head : Number of heads.
- Precomp : Write precompensation cylinder
- Landz : Landing zone.
- Sector : Number of sectors.
- Mode : Auto, Normal, Large, or LBA.
 - Auto: The BIOS automatically determines the optimal mode.
 - Normal: Maximum number of cylinders, heads, and sectors supported are 1024, 16, and 63.
 - Large: For drives that do not support LBA and have more than 1024 cylinders.
 - LBA (Logical Block Addressing): During drive accesses, the IDE controller transforms that data address described by sector, head, and cylinder number into a physical block address, significantly improving data transfer rates. For drives with greater 1024 cylinders.

There are four hard disks listed: "Primary Master", "Primary Slave", "Secondary Master" and "Secondary Slave". For each IDE channel, the first device is the "Master" and the second device is "Slave". Hard disk types from 1 to 45 are the standard one. To select or change the configuration, move the cursor to the desired position and press <Page Up> or <Page Down> to change the option.

The AWARD BIOS supports three HDD modes: NORMAL, LBA and LARGE.

NORMAL mode : This is a Generic Access mode in which neither the BIOS nor the IDE controller will make any transformation during the accession. The maximum HDD size is supported by the NORMAL mode that is 528 Megabytes.

LBA mode : This is a Logical Block Addressing mode which is a HDD accessing method to overcome the 528 Megabytes restriction. The number of cylinders, heads and sectors that are shown in setup may not be the physical number contained in the HDD.

During the HDD accessing, the IDE controller will transform the logical address that is described by the cylinder, head and sector numbers into its own physical address as contained inside the HDD. The maximum HDD size that is supported by the LBA mode is 8.4 Gigabytes.

LARGE mode : Some IDE HDD contains more than 1024 cylinders without the LBA support. This access mode tricks DOS (or other OS) with the number of cylinders that is less than 1024 by dividing it by 2. At the same time, the number of heads is multiplied by 2. A reverse transformation process will be made inside INT13H in order to access to the right HDD address. The maximum HDD size that is supported by the LARGE mode is 1 Gigabytes.

- Note :
1. To support LBA or LARGE mode, there are softwares located in the AWARD HD Service Routine "INT13H". It may fail to access a HDD with LBA or LARGE modes selected if you are running under an Operating System that replaces the whole INT13H service routine.
 2. Entering incorrect drive specifications will result in a hard disk drive that will function improperly or no function at all.

Drive A and Drive B : Select the correct specifications for the diskette drive(s) installed in the computer.

None	No diskette drive installed
360K, 5.25 in	5-1/4 inch PC-type standard drive; 360 kilobyte capacity
1.2M, 5.25 in	5-1/4 inch AT-type high-density drive; 1.2 megabyte capacity
720K, 3.5in	3 1-2 inch double-sided drive; 720 kilobyte capacity
1.44M, 3.5 in	3 1-2 inch double-sided drive; 1.44 megabyte capacity
2.88M, 3.5 in	3 1-2 inch double-sided drive; 2.88 megabyte capacity

Note : 1. Not Installed could be used as an option for diskless workstations..

2. Highlight the listing after each drive name and select the appropriate entry.

Video : Select the type of primary video subsystem in your computer. The BIOS usually detects the correct video type automatically. The BIOS supports a secondary video subsystem, but you do not select it in Setup.

EGA/VGA	Enhanced Graphics Adapter/Video Graphics Array. For EGA, VGA, SEGA, SVGA or PGA monitor adapters.
CGA 40	Color Graphics Adapter, power up in 40 column mode
CGA 80	Color Graphics Adapter, power up in 80 column mode
MONO	Monochrome adapter, includes high resolution monochrome adapters

Halt On : During the power-on-self-test (POST), the computer stops if the BIOS detects a hardware error. You can tell the BIOS to ignore certain errors POST and continue the boot-up process. These are the selections:

No errors	Whenever the BIOS detects a non-fatal error the system will not be stopped and you will be prompted
All errors	The system boot will be stopped for any error that may be detected.
All, But Keyboard	The system boot will not stop for a keyboard error ; it will stop for all Other errors.
All, But Diskette	The system boot will not stop for a disk error ; it will stop for all other Errors.
All, But Disk/Key	The system boot will not stop for a keyboard or disk error ; it will stop for all other errors.

Memory : You cannot change any values in the Memory fields; they are only for your information. The fields show the total installed random access memory (RAM) and amounts allocated to base memory, extended memory, and other (high) memory. RAM is counted in kilobytes (KB: approximately one thousand bytes) and megabytes (MB: approximately one million bytes).

RAM is the computer's working memory, where the computer stores programs and data currently being used, so they are accessible to the CPU. Modern personal computers may contain up to 64MB, 128MB, or more.

- **Base Memory** : Typically 640KB. Also called conventional memory. The DOS operating system and conventional applications use this area.
- **Extended Memory** : Above the 1-MB boundary. Early IBM personal computers could not use memory above 1MB, but current PCs and their software can use extended memory.
- **Other Memory** : Between 640KB and 1MB; called High memory. DOS may load terminate-and-stay-resident (TSR) programs, such as device drivers, in this area, to free as much conventional memory as possible for applications. Lines in your CONFIG.SYS file that start with LOADHIGH load programs into high memory.

3.4 BIOS Features Setup

When you select the “BIOS FEATURES SETUP” on the main program, the screen display will appear as:

BIOS Features Setup Screen

ROM PCI / ISA BIOS (2A59IL7P) BIOS FEATURES SETUP AWARD SOFTWARE, INC			
Virus Warning	:Disabled	Video BIOS Shadow	: Enabled
CPU Internal Cache	:Enabled	C8000-CBFFF Shadow	: Disabled
External Cache	:Enabled	CC000-CFFFF Shadow	: Disabled
Quick Power On Self Test	:Enabled	D0000-D3FFF Shadow	: Disabled
Boot Sequence	:A,C,SCSI	D4000-D7FFF Shadow	: Disabled
Swap Floppy Drive	:Disabled	D8000-DBFFF Shadow	: Disabled
Boot Up Floppy Seek	:Disabled	DC000-DFFFF Shadow	: Disabled
Boot Up NumLock Status	:On		
Boot Up System Speed	:High		
Gate A20 Option	:Fast		
Typematic Rate Setting	:Disabled		
Typematic Rate (Chars Sec.)	:6		
Typematic Delay (M/Sec)	:250		
Security Option	:Setup		
PCI/VGA Palette Snoop	:Disabled		
OS Select For DRAM	:Non-OS/2	ESC	: Quit ↑↓→← : Select Item
>64MB		F1	: Help PU /PD +/- : Modify
		F5	: Old Values (Shift) F2 : Color
		F6	: Load BIOS Defaults
		F7	: Load Setup Defaults

The following explains the options for each of the features as listed in the above menu:

Virus Warning : The default setting of the Virus Warning is “Disabled”. When it is enabled, any attempt to write the boot sector and partition table will halt the system and cause a warning message to appear. If this happens, you can use an anti-virus utility on a virus free, bootable floppy diskette to reboot, to clean and to investigate your system.

CPU Internal Cache : The default setting is “Enabled”. This setting enables the CPU internal cache .

External Cache : The default setting is “Enabled”. This setting enables the external cache.

Quick Power On Self Test : The default setting is “Enabled”. This speeds up the Power On Self Test (POST) by skipping some items that are normally checked during the full POST. If your system is functioning normally, you can choose this feature to speed the booting process.

Boot Sequence : The default setting is “C:,A:”; the other options are “CDROM, C, A” and “A, C” and “C, CDROM, A”. This setting determines where the computer looks first for an operating system, the hard disk, or the floppy disk, ...or other. The BIOS will load the operating system from the disk drives in the sequence as selected here.

Swap Floppy Drive : The default setting is “Disabled”. This setting gives you an option to swap A and B floppy disks. Normally, the floppy drive A is the one at the end of the cable and drive B is at the other end. If you set this option to “Enabled”, the Drive A will function as Drive B, and vice-versa under the DOS.

Boot Up Floppy Seek : The defaults setting is “Disabled”. When enabled, the BIOS will check whether there is a floppy disk drive installed.

Boot Up Numlock Status : The default setting is “On”. If set “Off”, the cursor controls will function on the numeric keypad.

Boot Up System Speed : The default setting is “High”. This sets the CPU speed at boot up.

Gate A20 Option : The default setting is “Fast”. This is the optimal setting for the CPU card. The other option is “Normal”.

Typematic Rate Setting : The default setting is “Disabled”. If enabled, you can set the typematic rate and typematic delay.

Typematic Rate (Chars/Sec) : This setting controls the speed at which the system registers the repeated keystrokes. The choices range from 6 to 30 Chars/Sec. The default setting is “6” Chars/Sec.

Typematic Delay (Msec) : This setting controls the time between the display of the first and second characters. There are four delay choices: 250ms, 500ms, 750ms and

1000ms. The default setting is “250” ms.

Security Option : This setting controls the password in the main screen. The options are “Setup” and “System”. Select “Setup” and it will protect the Setup Utility settings from being tampered with. Select “System” if you want to use password feature every time the system boots up. The default setting is “Setup”. You can create your password by using the “SUPERVISOR/USER PASSWORD” utility on the main program screen.

PCI/VGA Palette Snoop : The default setting is “Disabled”. Set to “Enable” if any ISA adapter card installed requires VGA palette snooping.

OS Select For DRAM > 64MB : The default setting is “Non-OS2”. Set to “OS2” if the system memory size is greater than 64MB and the operating system is OS/2.

Video BIOS Shadow : The default setting is “Enabled” which will copy the VGA display card BIOS into system DRAM to improve performance.

C8000-CBFFF Shadow to DC000-DFFFF Shadow : The default setting for the shadow feature is “Disabled”. When enabled, the ROM with the specific address is copied into system DRAM. It will also reduce the size of memory available to the system. After you have made your selection in the BIOS FEATURES SETUP, press the <ESC> key to go back to the main program screen.

3.5 CHIPSET FEATURES SETUP

When you select the “CHIPSET FEATURES SETUP” on the main program, the screen display will appear as:

Chipset Features Setup Screen

ROM PCI / ISA BIOS (2A59IL7P) CHIPSET FEATURES SETUP AWARD SOFTWARE, INC.			
AUTO Configuration	: Enabled	Spread Spectrum	: Disabled
DRAM Timing	: 60 ns	CPU Warning Temperature	: 70°C/158°F
DRAM R/W Leadoff Timing	: 10 / 6 / 3	Current CPU Temperature	: 29°C/84°F
DRAM Read Burst (EDO/FP)	:		
	x222/x333		
DRAM Write Burst Timing	: x222	Current SYSFAN Speed	: 0 RPM
Fast EDO Lead Off	: Enable	Current Vcore (V)	2.01V
Refresh RAS# Assertion	: 4 Clks	Current +3.3 (V)	3.30V
Fast RAS To CAS Delay	: 3	Current +5 (v)	4.77V
DRAM Page Idle Timer	: 2 Clks		
DRAM Enhanced Paging	: Enable		
Fast MA to RAS# Delay	: 2 Clks		
SDRAM (CAS Lat/RAS-to-CAS)	: 3 / 3		
SDRAM Speculative Read	: Disabled		
System BIOS Cacheable	: Disabled		
Video BIOS Cacheable	: Disabled	ESC : Quit	↑↓→←: Select Item
8 Bit I /O Recovery Time	: 1	F1 : Help	PU /PD /+/- : Modify
16 Bit I /O Recovery Time	: 2	F5 : Old Values (Shift) F2	: Color
Memory Hole At 15M-16M	: Disabled	F6 : Load BIOS Defaults	
PCI 2.1 Compliance	: Enabled	F7 : Load Setup Defaults	

This section describes features of the Intel 82430TX PCiset. If your system contains a different chipset, this section will bear little resemblance to what you seen on your screen.

Auto Configuration : The default setting is “Enabled” which will optimize DRAM timing automatically depending on whether the DRAM used is either 70ns or 60ns. The other option is “Disabled” which allows you to change DRAM timing manually.

DRAM Timing : Choose DRAM speed 60ns or 70ns.

DRAM R/W Leadoff Timing : Select the combination of CPU clocks the DRAM on your board requires before each read from or write to the memory.

DRAM Read Burst (EDO/FP) : Sets the timing for reads from EDO (Extended Data Output) or FPM (First Page Mode) memory. The lower the timing numbers, the faster the system addresses memory. Selecting timing numbers lower than the installed DRAM is able support can result in memory errors.

DRAM Write Burst Timing : Sets the timing for writes to memory. The lower the timing numbers, the faster the system addresses memory. Selecting timing numbers lower than the installed DRAM is able to support can result in memory errors.

Fast EDO Leadoff : Select Enabled only for EDO DRAMs in either a synchronous cache or cacheless system. It causes a 1-HCLK pull-in for all read leadoff latencies for EDO DRAMs (i.e., page hits, page misses, and row misses). Select Disabled if any of the DRAM rows are populated with FPM DRAMs.

Refresh RAS# Assertion : Select the number of clock ticks RAS# is asserted for refresh cycles.

Fast RAS# to CAS# Delay : When DRAM is refreshed, both rows and columns are addressed separately. This field lets you insert a timing delay between CAS and RAS strobe signals, used when DRAM is written to, read from, or refreshed. Disabled gives faster performance; Enabled give more stable performance.

DRAM Page Idle Timer : Select the amount of time in HCLKs that the DRAM controller waits to close a DRAM page after the CPU becomes idle.

DRAM Enhanced Paging : When Enabled, the chipset keeps the page open until a page/row miss. When Disabled, the chipset uses additional information to keep the DRAM page open when the host may be "right back."

Fast MA to RAS# Delay : The values in this field are set by the system board designer, depending on the DRAM installed. Do not change the values in this field unless you change specifications of the installed DRAM or the installed CPU.

SDRAM (CAS Lat/RAS-to-CAS) : You can select a combination of CAS latency and RAS-to-CAS delay in HCLKs of 2/2 or 3/3. The system board designer should set the values in this field, depending on the DRAM installed. Do not change the values in this field unless you change specifications of the installed DRAM or the installed CPU.

SDRAM Speculative Read : The chipset can “speculate” on a DRAM read address, thus reducing read latencies. The CPU issues a read request containing the data memory address. The DRAM controller receives the request. When this field is Enabled, the controller issues the read command slightly before it has finished decoding the data address.

System BIOS Cacheable : Selecting Enabled allows caching of the system BIOS ROM at F0000h-FFFFFh, resulting in better system performance. However, if any program writes to this memory area, a system error may result.

Video BIOS Cacheable : Selecting Enabled allows caching of the video BIOS ROM at C0000h to C7FFFh, resulting in better video performance. However, if any program writes to this memory area, a system error may result.

8/16 Bit I/O Recovery Time : The I/O recovery mechanism adds bus clock cycles between PC-originated I/O cycles to the ISA bus. This delay takes place because the PCI bus is so much faster than the ISA bus. These two fields let you add recovery time (in bus clock cycles) for 16-bit and 8-bit I/O.

Memory Hole At 15M-16M : The default setting is “Disabled”. Set to “Enabled” when the system memory size is equal to or greater than 16M bytes, then the physical memory address from 15M to 16M will be passed to PCI or ISA. Thus, there will be 1M Bytes hole in your system memory. This option is designed for some OS with special add-on cards which need 15M-16M memory space.

After you have made your selections in the CHIPSET FEATURES SETUP, press the <ESC> key to go back to the main program screen.

3.6 POWER MANAGEMENT SETUP

The “Power Management Setup” controls the CPU card’s “Green” features. When you select the “POWER MANAGEMENT SETUP” on the main program, the screen display will appear as:

Power Management Setup Screen

ROM PCI / ISA BIOS (2A59IL7P) POWER MANAGEMENT SETUP AWARD SOFTWARE, INC.	
Power Management : Disabled	** Reload Global Timer Events **
PM Control by APM : Yes	IRQ[3-7,9-15],NMI : Disabled
Video Off Method : V /H SYNC+ Blank	Primary IDE 0 : Disabled
MODEM Use IRQ : 3	Primary IDE 1 : Disabled
Doze Mode : Disabled	Secondary IDE 0 : Disabled
Standby Mode : Disabled	Secondary IDE 1 : Disabled
Suspend Mode : Disabled	Floppy Disk : Disabled
HDD Power Down : Disabled	Serial Port : Enabled
Throttle Duty Cycle : 62.5%	Parallel Port : Disabled
ZZ Active in Susoend : Disabled	
PCI/VGA Act Monitor : Disabled	
PowerOn by Ring : Disabled	
IRQ 8 Break Suspend : Disabled	
	ESC : Quit ↑↓→← : Select Item
	F1 : Help PU /PD/+/- : Modify
	F5 : Old Values (Shift) F2 : Color
	F6 : Load BIOS Defaults
	F7 : Load Setup Defaults

Power Management : This setting controls the System Doze Mode, Standby Mode and Suspend Mode Timer features. There are four options namely --

User Define : Allows you to customize all power saving timer features.

Optimize : This is the recommended setting for general use.

Test/Demo : This is for test/demonstration purpose.

Disable : Disable the power management features.

PM Control by APM : The default setting is “No”. If it is set to “Yes”, the system BIOS will wait for APM’s prompt before it enters any PM mode.

Note : If your system power management is controlled by APM and there is a task

running, the APM will not prompt the BIOS to enter any power saving mode after time out.

Video Off Method : This setting controls the Video off method in power saving mode. The default setting is "V/H SYNC+Blank". This setting disables V/H SYNC signals and blanks the screen into the power saving mode. Other options are "Blank Screen" and "DPMS".

Doze Mode : Options are from "1 Min." to "1 Hour" and "Disable". The system speed will change from turbo to slow and the video signal will be suspended, if no Power Management events occur for a specified length of time. Full power function will return when a Wake-Up event is detected.

Standby Mode : Options are from "1 Min" to "1 Hour" and "Disable". The system speed will change from turbo to slow and the video signal will be suspended, if no Power Management events occur for a specified length of time. Full power function will return when a Wake-Up event is detected.

Suspend Mode : Option are from "1 Min" to "1 Hour" and "Disable". The CPU clock will be stopped and the video signal will be suspended, if no Power Management events occur for a specified length of time. Full power function will return when a Wake-Up event is detected.

HDD Power Down : Options are from "1 Min." to "15 Min." and "Disable". The IDE hard drive will spin down if it is not accessed within a specified length of time.

Throttle Duty Cycle : When the system enters Doze mode, the CPU clock runs only part of the time. You may select the percent of time that the clock runs.

PCI/VGA Act-Monitor : When Enabled, any video activity restarts the global timer for Standby mode.

IRQ8 Clock Event : You can turn On or Off monitoring of IRQ8 (the Real Time Clock) so it does not awaken the system from Suspend mode.

Reload Global Timer Events : When Enabled, an event occurring on each device listed below restarts the global time for Standby mode.

IRQ3-7, 9-15, NMI

Primary IDE 0
Primary IDE 1
Secondary IDE 0
Secondary IDE 1
Floppy Disk
Serial Port
Parallel Port

Wake-Up Events : When a hardware event is enabled, the occurrence of a corresponding event will return the system to full speed.

Power Down/Resume Events : When a hardware event is enabled, the occurrence of a corresponding event will prevent the system from entering any PM mode.

After you have made your selection in the POWER MANAGEMENT SETUP, press the <ESC> key to go back to the main program screen.

3.7 PNP/PCI CONFIGURATION

Both the ISA and PCI buses on the CPU card use system IRQs & DMAs. You must set up the IRQ and DMA assignments correctly through the PnP/PCI Configuration Setup utility, otherwise the SBC will not work properly.

When you select the “PnP /PCI CONFIGURATION” on the main program, the screen display will appear as:

PnP/PCI Configuration Setup Screen

ROM PCI / ISA BIOS (2A59IL7P) PNP/PCI CONFIGURATION AWARD SOFTWARE, INC.					
PNP OS Installed	:	No	PCI IDE IRQ Map To	:	PCI-AUTO
Resources Controlled By	:	Manual	Primary IDE INT#	:	A
Reset Configuration Data	:	Disabled	Secondary IDE INT#	:	B
IRQ-3	assigned to	: Legacy	ISA	Used MEM base addr	: N/A
IRQ-4	assigned to	: Legacy	ISA		
IRQ-5	assigned to	: PCI/ISA	PnP		
IRQ-7	assigned to	: Legacy	ISA		
IRQ-9	assigned to	: PCI/ISA	PnP		
IRQ-10	assigned to	: PCI/ISA	PnP		
IRQ-11	assigned to	: PCI/ISA	PnP		
IRQ-12	assigned to	: PCI/ISA	PnP		
IRQ-14	assigned to	: PCI/ISA	PnP		
IRQ-15	assigned to	: PCI/ISA	PnP		
DMA-0	assigned to	: PCI/ISA	PnP		
DMA-1	assigned to	: PCI/ISA	PnP	ESC	: Quit
DMA-3	assigned to	: PCI/ISA	PnP	↑↓→←	: Select Item
DMA-5	assigned to	: PCI/ISA	PnP	F1	: Help
DMA-6	assigned to	: PCI/ISA	PnP	PU /PD/+/-	: Modify
DMA-7	assigned to	: PCI/ISA	PnP	F5	: Old Values (Shift)
				F2	: Color
				F6	: Load BIOS Defaults
				F7	: Load Setup Defaults

PNP OS Installed : Select Yes if the system operating environment is Plug-and-Play aware (e.g., Windows 95).

Resources Controlled By : The defaults setting is “Auto” which will control all IRQs and DMAs automatically. The other option is “Manual” which allows you to control IRQs and DMAs individually.

Reset Configuration Data : The default setting is “Disabled”. When set to “Enabled”, the content of the ESCD block in flash BIOS will be cleared.

RQ Assigned to and DMA Assigned to : If there is a legacy ISA device which uses an IRQ or a DMA, set the corresponding IRQ or DMA to “ Legacy ISA”; otherwise you should set to PCI/ISA PnP.

PCI IRQ Activated By : Options are “Level” or “Edge“. The default setting is ”Level“, this option is used to select the IRQ' s trigger method.

PCI IDE IRQ Map To, Primary IDE INT#, Secondary IDE INT# : If you disable the on-board PCI IDE controller and install a PCI IDE card on the SBC, you need to set this option. If a PCI IDE Card which uses ISA IRQ directly through a paddle card installed on an ISA slot, select “ISA” for the option “PCI IDE IRQ Map To”. If a PCI IDE Card uses PCI “INT” and is compliant to PCI Plug and Play specification, select “PCI-AUTO” for the option “PCI IDE IRQ Map To”. Otherwise, select “PCI-SLOT 1, PCI-SLOT 2 or PCI-SLOT 3, PCI-SLOT4) depending on which slot the PCI IDE Card is installed. Only INT# A and INT# B are available for a PCI IDE Card, therefore you must set the PCI IDE Card' s primary interrupt to INT A and secondary interrupt to INT B. The INT# A is routed to IRQ 14, while the INT# B is routed to IRQ 15 through a hardware router in the chipset.

Used MEM base addr : Because BIOSes fail to auto detect some specific ISA Legacy cards with requested memory space below 1M address, we have added the “Used MEM base addr” and “Used MEM Length” to support such kind of cards. Now, with these two functions, users can define where the used memory address is located and its length of the legacy area correspondingly. Based on this, BIOS will skip the UMB area that is used by the legacy device to avoid the memory space conflict. For example, if the user select “D000” for “Used MEM base addr” and “16K” for “Used MEM Length” that means the address region D0000H-D3FFFH is occupied by ISA legacy cards, and BIOS will not assign this region for PnP/ISA and PCI cards.

3.8 LOAD BIOS DEFAULTS

The BIOS defaults have been set by the manufacturer which represent settings provided with the minimum requirements for your system to operate. “ **Load BIOS Defaults** ” loads the troubleshooting default values permanently recorded in the BIOS ROM. These settings are non-optimal and turn off all high performance features.

The Standard CMOS Setup screen is not affected. To use this feature, highlight it on the main screen and press <Enter>. A line will appear asking if you want to load the BIOS default values. Press the <Y> key and the <Enter>. The default settings will load. Press <N> if you do not want to proceed.

ROM PCI / ISA BIOS (2A59IL7P) CMOS SETUP UTILITY AWARD SOFTWARE, INC.	
STANDARD CMOS SETUP BIOS FEATURES SETUP CHIPSET FEATURES SETUP POWER MANAGEMENT SETUP PNP / PCI CONFIGURATION LOAD BIOS DEFAULTS	INTEGRATED PERIPHERALS SUPERVISOR PASSWORD USER PASSWORD IDE HDD AUTO DETECTION HDD LOW LEVEL FORMAT SAVE & EXIT SET\UP LOAD SETUP DEFA
ESC : Quit F10 : Save & Exit Setup	Load BIOS Default (Y/N)? Y : Select Item (Shift) F2 : Change Color
Time, Date, Hard Disk Type....	

3.9 LOAD SETUP DEFAULTS

“LOAD SETUP DEFAULTS” loads the optimal settings which are stored in BIOS ROM. The defaults loaded affect only the BIOS Features Setup, Chipset Features Setup, Power Management Setup, PnP/PCI configuration setup and Integrated Peripherals Setup. There is no effect on the Standard CMOS Setup. To use this feature, highlight the entry on the main screen and press <Enter>. A line will appear on the screen asking if you want to load the Setup default values. Press the <Y> key and then press the <Enter> key if you want to load the Setup defaults. Press <N> if you do not want to proceed.

3.10 INTEGRATED PERIPHERALS

When you select the “INTEGRATED PERIPHERALS” on the main program, the screen display will appear as:

Integrated Peripheral Setup Screen

ROM PCI / ISA BIOS (2A59IL7P) INTEGRATED PERIPHERALS AWARD SOFTWARE, INC.			
IDE HDD Block Mode	: Enabled	Onboard Parallel Port	: 378/IRQ7
IDE Primary Master PIO	: Auto	Parallel Port Mode	: SPP
IDE Primary Slave PIO	: Auto		
IDE Secondary Master PIO	: Auto		
IDE Secondary Slave PIO	: Auto		
IDE Primary Master UMDA	: Auto		
IDE Primary Slave UMDA	: Auto		
IDE Secondary Master UMDA	: Auto		
IDE Secondary Slave UMDA	: Auto		
On-Chip Primary PCI IDE	: Enabled		
On-Chip Secondary PCI IDE	: Enabled		
USB Keyboard Support	: Disabled		
KBC input clock	: 8 MHz		
Onboard FDC Controller	: Enabled		
Onboard Serial Port 1	: 3F8 / IRQ4	ESC : Quit	↑↓→← : Select Item
Onboard Serial Port 2	: 2F8 / IRQ3	F1 : Help	PU /PD/+/- : Modify
UART Mode Select	: Normal	F5 : Old Values (Shift)	F2 : Color
		F6 : Load BIOS Defaults	
		F7 : Load Setup Defaults	

IDE HDD Block Mode : The Default setting is “Enabled”. This feature enhances the hard disk performance by making multi-sector transfers instead of one sector per transfer. Most IDE drives, except the very early design, have Block Mode transfer feature.

IDE Primary Master PIO, IDE Primary Slave PIO, IDE Secondary Master PIO, IDE Secondary Slave PIO : There are four IDE PIO (Programmed Input/Output) fields let you set a PIO mode (0-4) for each of the four IDE devices that the onboard IDE interface supports. Modes 0 through 4 provide successively increased performance. In Auto mode, the system automatically determines the best mode for each device.

IDE Primary Master UMDA, IDE Primary Slave UMDA, IDE Secondary Master UMDA, IDE Secondary Slave UMDA : Ultra DMA/33 implementation is possible only if your IDE hard drive supports it and the operating environment includes a DMA driver (Window 95 OSR2 or a third-party IDE bus master driver). If your hard drive and your system software both support Ultra DMA/33, select Auto to enable BIOS support.

On-Chip Primary/Secondary PCI IDE : The default setting is “Enabled”. This option enables the onboard Primary /Secondary PCI IDE controller.

USB Controller : Select Enabled if your system contains a Universal Serial Bus (USB) controller and you have a USB keyboard.

Onboard FDC Controller : Select Enabled if your system has a floppy disk controller (FDC) installed on the system board and you wish to use it. If you install an add-in FDC or the system has no floppy drive, select Disabled in this field.

Onboard Serial Port 1 / 2: These options are used to assign the I/O addresses for the two on-board serial ports. They can be assigned as follows:

Auto [**Default**]

3F8 / IRQ4

2F8 / IRQ3

3E8 / IRQ4

2E8 / IRQ3

Disabled (Disable the onboard serial port)

Onboard Parallel Port : This option is used to assign the I/O address for the onboard parallel port. The options are “378/IRQ7” (defaults), “278/IRQ7”, “3BC/IRQ7” and “Disabled” (disable the onboard parallel port). Note: Printer port always use IRQ7 when set to “378/IRQ7” or “278/IRQ7”, or from “3BE/IRQ7” to “Enabled”.

Parallel Port Mode: There are four options “Normal” (default), “ECP”, “ECP/EPP” and “EPP/SPP”. Change the mode from “Normal” to the enhanced mode only if your peripheral device can support it. When it is set to ECP mode, the printer port always uses DMA3.

3.11 SUPERVISOR/USER PASSWORD

The “SUPERVISOR/USER PASSWORD” utility sets the password. The SBC is shipped with the password disabled. If you want to change the password, you must first enter the current password, then at the prompt -- enter your new password. The password is case sensitive, and can be up to 8 alphanumeric characters. Press <Enter> after you have finished typing in the password. At the next prompt, confirm the new password by re-typing it and pressing <Enter> again. When you are done, the screen automatically reverts to the main screen. Remember that when you use this feature, the “Security Option” line in BIOS FEATURES SETUP will determine when entering the password will be required.

To disable the password, press the <Enter> key instead of entering a new password when the “Enter Password” in the dialog box appears. A message will appear confirming that the password is disabled.

If you have set both supervisor and user password, only the supervisor password allows you to enter the BIOS SETUP PROGRAM.

Note : If you forget your password, the only way to solve this problem is to discharge the CMOS memory by turning power off and placing a shunt on the S1 (open pad) for 5 seconds, then removing the shunt.

3.12 IDE HDD AUTO DETECTION

If your system has an IDE hard drive, you can use this utility to detect its parameters and enter them into the Standard CMOS Setup automatically.

If the auto-detected parameters displayed do not match the ones that should be used for your hard drive, do not accept them. Press the <N> key to reject the values and enter the correct ones manually on the Standard CMOS Setup screen.

Note : If you are setting up a new hard disk drive (nothing on it) that supports LBA mode, more than one line will appear in the parameter box, choose the line that lists LBA for an LBA drive.

Do not choose Large or Normal if the hard disk drive is already fully formatted when you install it, choose the mode “HDD Low Level Format” to format it.

3.13 HDD LOW LEVEL FORMAT

Select and highlight this option press the <Enter> key to enable you to perform the low level format of hard disk drive.

3.14 SAVE & EXIT SETUP

Select this option and press the <Enter> key to save the new setting information in the CMOS memory and continue with the booting process.

3.15 EXIT WITHOUT SAVING

Select this option and press the <Enter > key to exit the Setup Utility without recording any new values or changing old ones.

4.1 USE YOUR DRIVER CD-ROM

This chapter provides information of how to install the drivers that come with the CD-ROM in the package. Please follow the instructions set forth in chapter carefully.

1. Find the directory for your O/S accordingly.
2. Always read the README.TXT before installation.
3. Run the *.EXE., and follow the installation prompt step by step.

4.2 FILE DIRECTORY

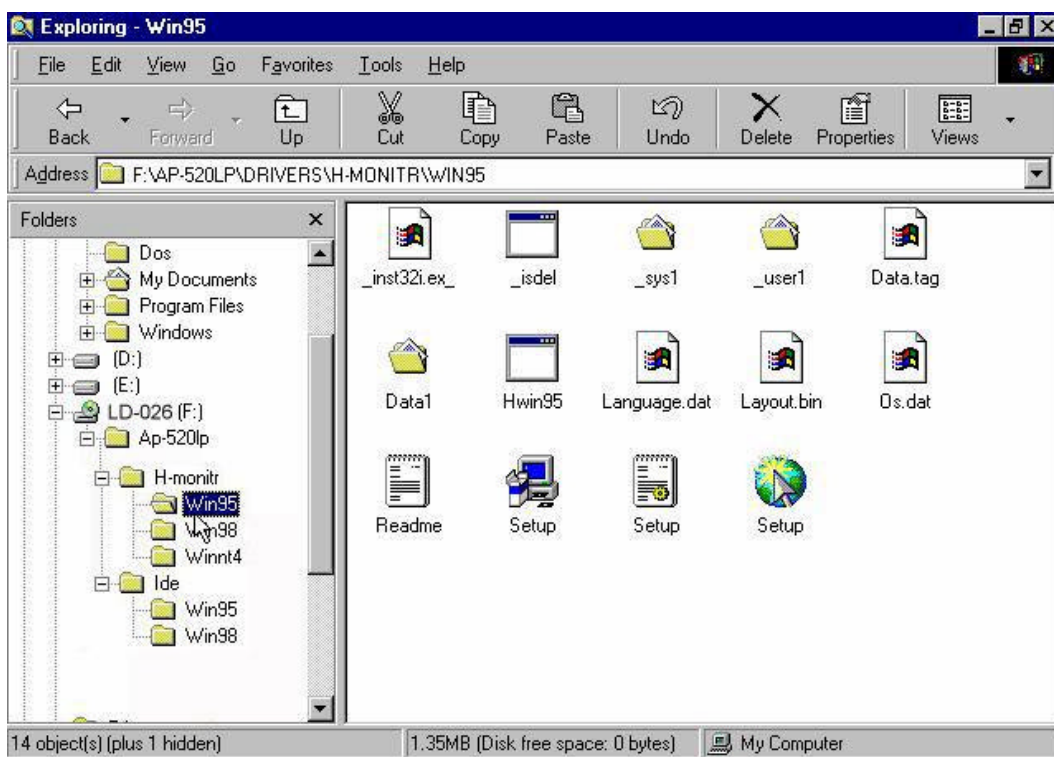

APPENDIX A

HOW TO USE WATCH-DOG TIMER

You can enable the watch-dog when your application software monitors an unexpected or not respond, then the timer generates a reset to reboot your system. During the period of enable to reset, you could still cancel reset by disable the watch-dog. Decision the way you want to set the period for reset by select hardware or software watch-dog (if both of them are available). For hardware setting period, select period by jumper. For software setting period, normally setting hardware watch-dog timer period to 16 sec.

Hardware watch-dog using example

EX.1: For DOS

Execute the **DEBUG.EXE** under DOS, Then key-in **i443**. The system will reboot automatically according to the time-out you set.

Enable

```
C:\DOS> DEBUG
-i443
```

Disable

```
C:\DOS>DEBUG
-i43
```

EX.2: For assemble Language

Enable :

```
MOV DX, 443H
IN AL, DX
```

Disable :

```
IN AL, 43H
```

Software watch-dog using example

EX.1: For DOS

Enable

```
C:\DOS> DEBUG
-o443F
```

Disable

```
C:\DOS>DEBUG
-o441F
```

EX.2: For assemble Language

Enable :

```
MOV DX, 443H
MOVAL, 0FH
OUTDX, AL
```

Disable :

```
MOV DX, 441H
MOV AL, 0FH
OUT DX, AL
```

Note : "F" is the period of software watch-dog timer (normally "F" indicated 0 sec.). 0 to 9 and A to F are used for represent different period. Normally, the step is 2 sec. That means "E" is 2, "D" is 4, "2" is 26, "1" is 28 and "0" is 30 seconds.

APPENDIX B

TECHNICAL REFERENCE

I/O PORT ADDRESS MAP

Address	Function
000 - 01F	DMA Controller #1
020 - 03F	Interrupt Controller #1
040 - 05F	Timer Chip
043	Disable Watch-Dog Times Operation (Read)
060 - 06F	Keyboard Controller
070 - 07F	Read Time Clock/NMI Mask
080 - 09F	DMA Page Register
0A0 - 0BF	Interrupt Controller #2
0C0 - 0DF	DMA Controller #2
0F0 - 0F1	Clear/Reset Math Coprocessor
1F0 - 1F7	Hard Disk Controller
200 - 210	Game Port
278 - 27F	Parallel Port #2
2E8 - 2EF	Serial Port #4 (COM 4)
2F8 - 2FF	Serial Port #2 (COM 2)
300 - 31F	prototype Card/Streaming Tape Adapter
360 - 36F	PC Network
378 - 3FF	Parallel Port #1
380 - 38F	SDLC #2
3A0 - 3AF	SDLC #1
3B0 - 3BF	MDA Video Card (Including LPT0)
3C0 - 3CF	EGA Card
3D0 - 3DF	CGA Card
3E8 - 3EF	Serial Port #3 (COM 3)
3F0 - 3F7	Floppy Disk Controller
3F8 - 3FF	Serial Port #1 (COM 1)
443	Enable Watch-dog Timer Operation (read)

MEMORY ADDRESS MAP

Address Range (Hex)	Description
000000H - 09FFFFH	640 KB of Conventional RAM
0A0000H - 0BFFFFH	128 KB of Video RAM
0C0000H - 0EFFFFH	256 KB of I/O Expansion ROM
0F0000H - 0FFFFFFH	64 KB of System BIOS ROM
0100000H - 7FFFFFFFH	1 MB ~ 128MB of User RAM

DMA CHANNELS

CHANNEL	Function
DMA 0	Reserved
DMA 1	Reserved
DMA 2	Floppy Disk Controller
DMA 3	ECP Parallel Port
DMA 4	Cascade for DMA #1
DMA 5	Reserved
DMA 6	Reserved
DMA 7	Reserved

INTERRUPT CONTROLLER

IRQ	Function
IRQ 0	System timer output
IRQ 1	Keyboard
IRQ 2	Cascade for INTC #2
IRQ 3	Serial port #2
IRQ 4	Serial port #1
IRQ 5	Parallel port #2
IRQ 6	Floppy disk controller
IRQ 7	Parallel port #1
IRQ 8	Real time clock
IRQ 9	Software redirected to INT 0AH (IRQ 2)
IRQ 10	Reserved
IRQ 11	Reserved
IRQ 12	PS/2 Mouse
IRQ 13	Math Coprocessor (CPU Internal)
IRQ 14	Primary Hard disk
IRQ 15	Secondary Hard Disk
NMI	Parity Check Error

GLOSSARY

8-Bit Bus – Data is transmitted to expansion slots and other components on the bus only along 8 parallel data line.

10Base-T – It is a 10Mbps IEEE 802.3/Ethernet standard that uses un-shielded twisted pair cable specification. 10Base-T supports network configuration using the CSMA/CD access method over a twisted pair transmission system up to 100 meters in length without the use of repeater.

16-Bit Bus or ISA Bus – Data is transmitted along either 8 or 16 data lines, depending on what kind of adapter card is used in an expansion slot. ISA is the abbreviation of Industry Standard Architecture.

100Base-TX – It is a 100Mbps IEEE 802.3/Ethernet standard that uses UTP cable. Also called Fast Ethernet, it uses RJ-45 connectors and EIA/TIA T568B pinning. Maximum cable length from hub to node is 100 meters without a repeater.

Adapter – It is also called an expansion board, expansion card, or adapter card. It is a small circuit board that is installed in the expansion slots on the motherboard. You can install a particular adapter that connects a new device such as internal modem, sound card, and scanner.

AGP (Accelerated Graphic Port) – is a 32-bit, 66MHz external frequency data bus that transmit a maximum of 528MB/s of data (4 times the speed of PCI transmission); this design improves the speed of large amount in video transaction.

BIOS (Basic Input /Output System) – This is a chip on the motherboard that contains the instructions for starting up, or booting, the computer, and more.

Bus – Data that travels in a computer along the circuits on the motherboard are called buses. Although three main buses (data bus, address bus, and control bus) manage the computer's operation, often these are collectively called the bus. The bus carries instructions back and forth between the CPU and other devices in the system. ISA, EISA, VL-Bus, PCI and SCSI are examples of PC buses.

bps – Bits per second. Also often preceded by K (kilo/thousands), Kbps – Kilo bytes per second, and M (mega/million), Mbps – Mega bytes per second.

Bus Mastering – A method of transferring data through a bus in which the device takes over the bus and directly controls the transfer of data to the computer’s memory. Bus mastering is a method of Direct Memory Access (DMA) transfer.

Cache – Cache RAM is an extra holding area for program instructions that need to be frequently used by the CPU or swapped in and out of RAM. Your CPU can usually access those instructions from the cache more quickly than it could from a hard disk or even RAM, so a cache helps the system work more efficiently. Most systems sold today offer either 256K or 512K cache.

CPU (Central Processing Unit) – executes all commands and controls the flow of data, providing the “ brain ” that enables the PC to calculate and perform the operations like sorting information more quickly than a human could. The CPU makes perhaps the greatest contribution to a PC’s speed and power. Note: Any additional information is subject to change without prior revision from the supplier.

Table 1 -- CPU Speeds

Processor type	Speed ratings (MHz)
486DX2	66, 80
486DX4	75, 100, 120
Pentium	90, 100, 120, 133, 166, 200
Pentium MMX	166, 200, 233
Pentium Pro	166, 180, 200
Pentium II	233, 266, 300, 333

EIDE (Enhanced IDE) – It is a hard drive controller that enables your system to be able to handle fast hard disk drives at a speed of 10Mbps.

EISA or MCA Bus – Data is transmitted along 32 data lines to adapter cards designed specifically to work with the 32-bit buses. MCA expansion slots cannot accept 8-bit or 16-bit adapter cards. EISA stands for Extended Industry Standard Architecture, while MCA stands for MicroChannel Architecture. MCA is architecture used in IBM Microcomputer.

Expansion slots – Expansion slots are plug-in connectors that allow you to insert additional circuit boards that attach to the rest of the PC through special circuitry called the bus. By inserting the right circuit board -- usually called an adapter or an expansion card – you can increase the resolution and the number of colors used by the display, or you can transform your PC into a machine for recording and playing music.

Fast SCSI – The common nomenclature associated with SCSI2, the second generation of SCSI offering mandatory parity checking improvements over SCSI-1.

IDE (Integrated Drive Electronics) – It was developed from ST-506 type hard drive interface, utilizes BIOS INT 13h hard drive secondary software and supports two hard drives (Master and Slave). Do not need extra software to drive since it is directly initiated in the BIOS. Data transfer rate is 4.1 Mbps. Take note that this interface cannot support other drive like CD-ROM drive.

IEEE (Institute of Electrical and Electronic Engineers) – It is an international professional society that issues its own standard, and is a member of ANSI and ISO. Popular known standards is:

- IEEE802.3 – is a physical layer standard for 10Base-T, 100Base-T, Ethernet, and StarLAN.
- IEEE802.5 – is a physical layer standard for Token Ring.
- IEEE802.11 – is a physical layer standard for Wireless LAN/WAN compatibility.
- IEEE802.12 – is a physical layer standard for 100VG AnyLAN.

LAN (Local Area Network) – A data communications network spanning a limited area. It provides communications between three or more computers and peripherals, in most cases using a high-speed media as it' s backbone.

Keyboard – This is a component that comes in direct contact for you with your PC. The mechanism of keyboard converts a key cap's movement into a signal sent to the computer. The most common key mechanism are "capacitate" and "hard contact". Capacitate keyboard has a spring that causes the plastic and the metal plunger to move nearer to two pads that have large plates (plated in tin, nickel, and copper). These pads are connected to the keyboard's printed circuit board. Hard contact keyboard causes the key cap to collapse a foam rubber dome that presses against a sheet of plastic on the bottom of which is metallic area connected to the rest of the keyboard's circuit board.

LDCM (LANDesk Client Manager) – With the help of LDCM, PCs that are either stand-alone or on a network can not escape the control of a system administrator. Alerts will be sent to the user if an abnormal condition is encountered in a PC. It allows the administrator to give each PC a thorough check-up. Additionally, this feature is available to multiple OS's on the market today. LDCM Key Features include the following : ←Health Monitoring , ↑Real-Time Alerting , →Remote Accessibility , ↓Extensive Instrumentation. This is a product from Intel.

Mouse – The keyboard is a barrier to learn how to use a computer. Xerox Corporation first developed the concept of a pointing device, something a computer user could move with his or her hand, causing a corresponding move on screen. Because of its size and tail like cable, the device was named for the mouse. Apple Computer made the mouse a standard feature of its Macintosh computers, and with the popularity of Windows, a mouse is becoming standard equipment on all PCs, as well. The "Trackball" have survived more awkward methods of navigating with the keyboard. "Digitizing tablets" are popular with architects and engineers who must translate precise movements of a pen into lines on the screen. "Touch screens", on which you press either your finger and a special light pen to control the software, are too tiring to use for any length of time.

MMX[®] – CPU's with MMX[™] technology are optimized to run multimedia application, and therefore, offer faster multimedia playback than standard CPUs. However, when manufacturers introduce any new hardware technology, the software makers need to catch up. At this time of compilation, most applications can't yet take advantage of MMX[™] capabilities.

Parallel port – Parallel ports (labeled LPT1, LPT2, and so on) are usually for plugging in printers. It is also often called a Centronics port – has been almost synonymous with printer port. Although a serial port can also be used to send data from a PC to some models of printers, the parallel port is faster. A serial port sends data one bit at a time over a single one-way wire; a parallel port can send several bits of data across eight parallel wires simultaneously. Take note that a serial connection sends a single bit, a parallel port send an entire byte.

PCI Bus (Peripheral Component Interconnect) – It is a connection slot in a motherboard that supports 32-bit bus transfer rates. The now standard PCI Local Bus carries data along at least 32 lines, that is, at least 32 bits at a time. Local bus computer designs add special buses so the CPU can communicate directly with key components like the monitor, resulting in much better performance. You should look for PCI local bus capabilities in any system you buy, especially PCI local bus video (which helps the monitor display more quickly).

POST (Power-On Self-Test) – is the first thing your PC does when you turn it on, and it's your first warning of trouble with any of the components. When the POST detects an error from the display, memory, keyboard, or other basic components, it produces an error warning in the form of a message on your display and—in case your display is part of the problem—in the form of a series of beeps.

RAM (Random Access Memory) – consists of a bank of chips that act as “ working memory ”, holding program instructions and data only while your computer's on. Unless the instructions and data are saved to a disk, RAM forgets them when you turn your computer off. RAM is measured in megabytes (M). Most computers today come with 32M of RAM, though some sell with only 16M installed. There are a few different flavors and speeds of RAM, as well. One of the most prominent today is Extended Data Output (EDO) RAM, but an even faster type of RAM that has just hit the market is called SyncDRAM.

Serial port – Serial ports are also sometimes called COM (short for COMmunications) ports, and are labeled COM1, COM2, and so on. It is simple in concept: one line to send data, another line to receive data, and a few other lines to regulate how data is sent over the other two lines – from commonplace modems and printers to plotters and burglar alarms. The most common use for serial port is with a mouse or modem. The reason for this is that a serial port is not a very efficient way to transfer data, so little data

that speed is not crucial, and perfect for modems because. With current technology, phone lines cannot transport more than one signal at a time anyway. The serial port is often referred to as an RS-232 port.

SCSI (Small Computer System Interface) – An intelligent bus for transmitting data commands between a variety of devices. There are many implementations of SCSI, including Fast SCSI, Wide SCSI, Fast Wide SCSI, Fast-20, and Fast-40.

SCSI-2 – The second generation of SCSI; includes many improvements to SCSI-1, including Fast SCSI, Wide SCSI, and mandatory parity checking.

SCSI-3 – The third generation of SCSI; introduces Fast-20 and Fast-40 as improvements to the parallel bus. The standard also includes a number of specifications for high-speed serial bus architectures such as SSA, Fiber Channel, and IEEE 1394. Also known as Ultra SCSI.

Ultra SCSI – Also known as SCSI-3, is a third generation SCSI standard that introduced parallel bus speed improvements (FAST-20 and FAST-40), and the miniaturized 68-pin micro connector.

USB (Universal Serial Bus) – USB consolidates serial, parallel, keyboard, mouse, and game ports into one asynchronous and isochronous communications port with bandwidth for data transfer speeds up to 12 Mbps without termination. By daisy-chaining USB hubs, up to 127 I/O devices can be connected to one USB port on the PC. USB is completely plug-and-play meaning peripherals can be correctly detected and configured automatically as soon as they are connected.

UTP (Unshielded Twisted Pair) – Twisted pair cable with neither individual nor overall shielding. Twisted Pair are two wires twisted together to reduce susceptibility to RF crosswalk.

VGA (Video Graphics Array) – A video adapter that supports 640x480 pixels color resolution. The Windows OS provides medium text & graphics standard.

VL-Bus – It is also known as Local Bus; this is an I/O interface that is directly connected and depended of the system CPU. The VL-Bus is an abbreviation of VESA Local Bus.

Terms and Conditions

Date:1997.10.20

Warranty Policy

1. All products are warranted against defects in materials and workmanship on a period of two years from the date of purchase by the customer.
2. The buyer will bear the return freight charges for goods that are returned for repair within the warranty period whereas manufacturer will bear the other way after repair.
3. The buyer will pay for repair (for the replaced materials plus service time) and transportation charges (both ways) for items after the expiration of the warranty period.
4. If the RMA Service Request Form does not meet the stated requirement as listed on "RMA Service" , RMA goods will be returned at the customer expense.
5. The following conditions are excluded from this warranty :
 - A. Improper or inadequate maintenance by the customer.
 - B. Unauthorized modification or misuse.
 - C. Operation outside of the environmental specifications for the product.

RMA Service

1. Request a RMA#:

Complete and fax to Supplier the "RMA Request Form" to obtain a RMA number.

2. Shipping:

- A. The customer is requested to fill up the problem code as listed . If none of the code is selected, please write the symptom description on the remark.
- B. Ship the defective units with freight prepaid.
- C. Mark the RMA # clearly on the box.
- D. Shipping damage as a result of inadequate packing is the customer's responsibility.
- E. Use the original packing materials whenever possible .

3. All RMA# are valid for 30 days only:

When RMA goods are received after valid RMA# period , the goods will be rejected.

